

DRAWING NUMBER
03-640-114
NPI OR ECN NO
ECN C000573

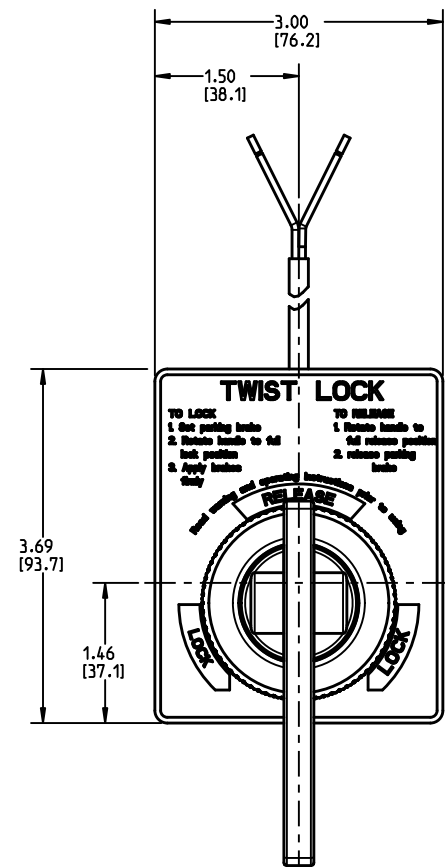
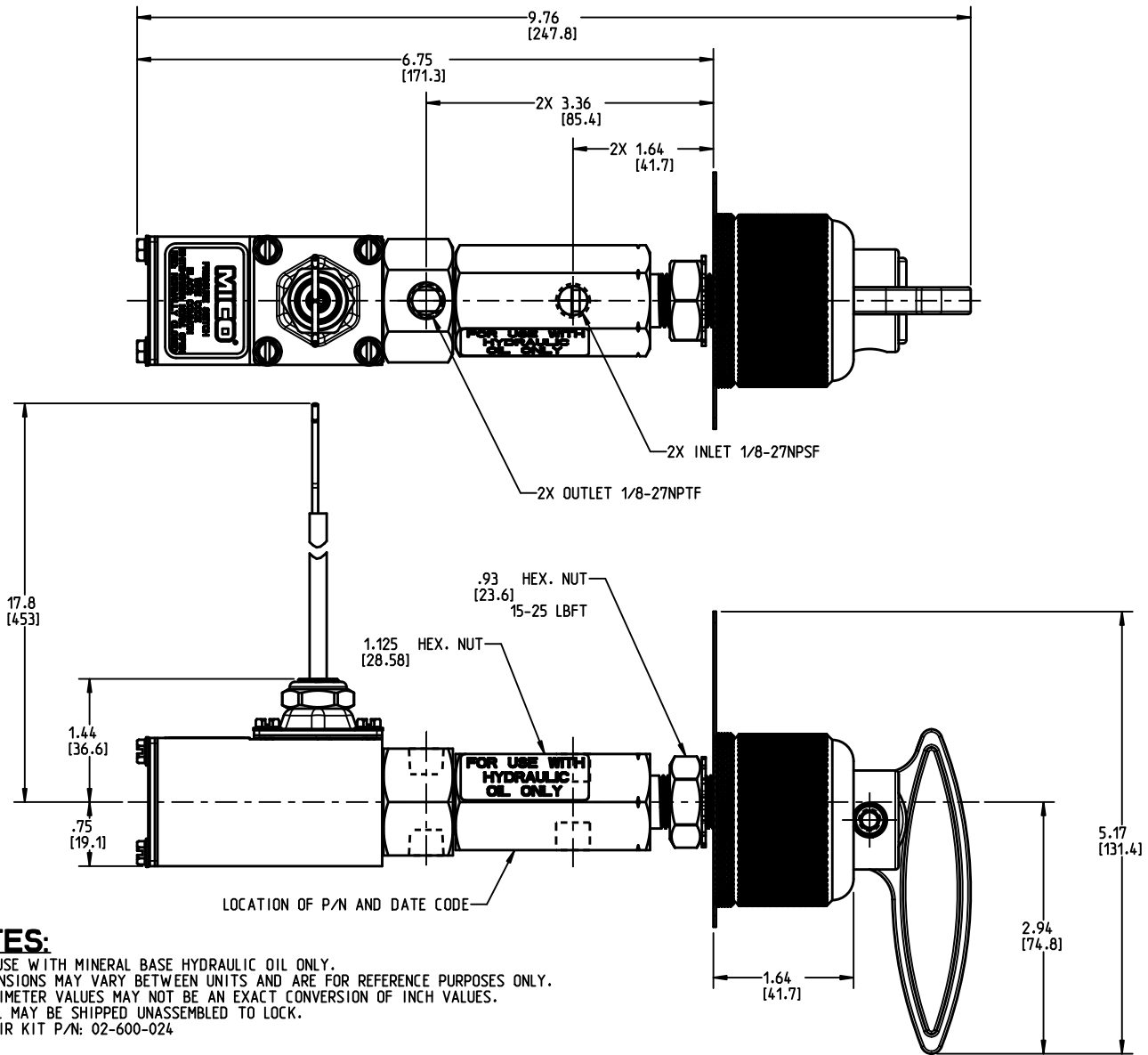

NOTES:

- FOR USE WITH MINERAL BASE HYDRAULIC OIL ONLY.
- DIMENSIONS MAY VARY BETWEEN UNITS AND ARE FOR REFERENCE PURPOSES ONLY. MILLIMETER VALUES MAY NOT BE AN EXACT CONVERSION OF INCH VALUES.
- LABEL MAY BE SHIPPED UNASSEMBLED TO LOCK.
- REPAIR KIT P/N: 02-600-024

PERFORMANCE CHARACTERISTICS:

- PRESSURE SETTINGS TO BE AS FOLLOWS:
- CONTACTS OPEN BY 750 PSI MAX. INCREASING.
- CONTACTS CLOSE BY 550 PSI MIN. DECREASING.
- WEATHER RESISTANT ADJUSTABLE PRESSURE SWITCH:
- PROOF PRESSURE: 15,000 PSI
- LEAD WIRE LENGTH: 16" APPROXIMATE
- WIRE CODE: BLACK - COMMON
RED - NORMALLY CLOSED
- SWITCH SPECIFICATIONS:
- SINGLE POLE DOUBLE THROW

RATED			
12 VDC	30 VDC	125 VAC	250 VAC
3 AMPS INDUCTIVE	3 AMPS INDUCTIVE	5 AMPS	5 AMPS
5 AMPS RESISTIVE	5 AMPS RESISTIVE		

COMPONENT AND SYSTEM RECOMMENDATIONS MADE BY MICO, INC ARE BASED ON INFORMATION SUPPLIED BY POTENTIAL USER AND/OR SYSTEM DESIGNER. THE POTENTIAL USER AND/OR DESIGNER MUST MAKE FINAL ACCEPTANCE AND APPROVAL OF COMPONENTS AND SYSTEM AFTER TESTING PERFORMANCE ON AN ACTUAL APPLICATION FOR WHICH SYSTEM WAS DESIGNED.

MICO, INC CLAIMS PROPRIETARY RIGHTS TO THE MATERIAL DISCLOSED IN THIS DOCUMENT. THIS DOCUMENT IS PROVIDED IN CONFIDENCE AND MAY NOT BE REPRODUCED OR DISCLOSED WITHOUT WRITTEN PERMISSION FROM MICO, INC. COPYRIGHT MICO, INC. ALL RIGHTS RESERVED.

INCH
[MILLIMETER]

MICO[®]
North Mankato, Minnesota USA

SCALE 0.500		TITLE TWIST LOCK		
DWN JRA 2015-08-20	APVD PROD ENGRG DPD 2015-08-25	SIZE A	DRAWING NUMBER 03-640-114	REV G
X NO X3653	APVD ENGRG BSW 2015-08-24		CUSTOMER COPY	2 1