

DRAWING NUMBER
03-020-551
NPI OR ECN NO
ECN B000986

WARNING
REMOVE THIS TAG
AND CLIP BEFORE
INSTALLATION

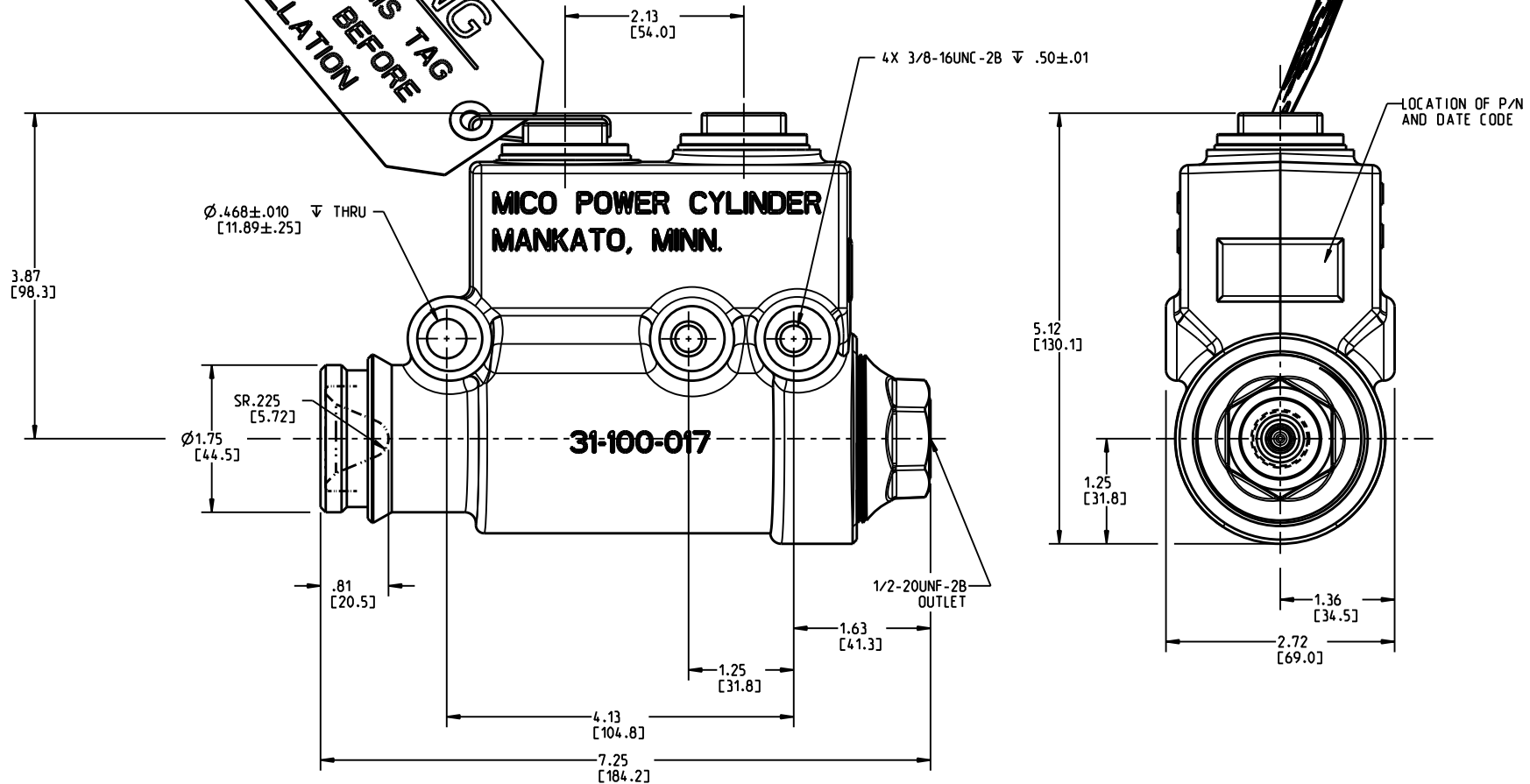

INCH
[MILLIMETER]

NOTES:

1. TO BE USED WITH DOT 3, 4 OR 5 BRAKE FLUID ONLY.
2. DIMENSIONS MAY VARY BETWEEN UNITS AND ARE FOR REFERENCE PURPOSES ONLY. MILLIMETER VALUES MAY NOT BE AN EXACT CONVERSION OF INCH VALUES.
3. SURFACE COATING: OLIVE DRAB PRIMER PER DOD-P-15328 SPECIFICATION.
4. REPAIR KIT P/N 02-001-235.
5. WHEN RESIDUAL CHECK VALVE IS REMOVED PART NUMBER IS 03-021-551.

PERFORMANCE CHARACTERISTICS:

1. RELIEF VALVE SETTING IS 175 PSI.
2. LOW PRESSURE BORE: $\varnothing 1.75$ IN.
3. HIGH PRESSURE BORE: $\varnothing 1.13$ IN.
4. STROKE: 1.44 IN.

COMPONENT AND SYSTEM RECOMMENDATIONS MADE BY MICO, INC ARE BASED ON INFORMATION SUPPLIED BY POTENTIAL USER AND/OR SYSTEM DESIGNER. THE POTENTIAL USER AND/OR DESIGNER MUST MAKE FINAL ACCEPTANCE AND APPROVAL OF COMPONENTS AND SYSTEM AFTER TESTING PERFORMANCE ON AN ACTUAL APPLICATION FOR WHICH SYSTEM WAS DESIGNED.

MICO, INC CLAIMS PROPRIETARY RIGHTS TO THE MATERIAL DISCLOSED IN THIS DOCUMENT. THIS DOCUMENT IS PROVIDED IN CONFIDENCE AND MAY NOT BE REPRODUCED OR DISCLOSED WITHOUT WRITTEN PERMISSION FROM MICO, INC. COPYRIGHT MICO, INC. ALL RIGHTS RESERVED.



North Mankato, Minnesota USA

SCALE 0.500		TITLE POWER CYLINDER		
DWN JRA 2011-02-16	APVD PROD ENGRG DPD 2011-02-18	SIZE A	DRAWING NUMBER 03-020-551	REV C
X NO	APVD ENGRG BSW 2011-02-16		CUSTOMER COPY	1 7