

NOTES:

- FOR USE WITH DOT 3, 4 OR 5 BRAKE FLUID ONLY.
- DIMENSIONS MAY VARY BETWEEN UNITS AND ARE FOR REFERENCE PURPOSES ONLY. MILLIMETER VALUES MAY NOT BE AN EXACT CONVERSION OF INCH VALUES.
- LABEL MAY BE SHIPPED UNASSEMBLED.

PERFORMANCE CHARACTERISTICS:

- PRESSURE SETTING TO BE AS FOLLOWS:
 - CONTACTS OPEN BY 750 PSI MAX. INCREASING.
 - CONTACTS CLOSE BY 550 PSI MIN. DECREASING.
- WEATHER RESISTANT ADJUSTABLE PRESSURE SWITCH:
 - PROOF PRESSURE: 15,000 PSI.
 - LEAD WIRE LENGTH: 16" APPROXIMATE.
 - WIRE CODE: BLACK - COMMON
RED - NORMALLY CLOSED
- SWITCH SPECIFICATION:
 - SINGLE POLE DOUBLE THROW.

RATED			
12 VDC	30 VDC	125 VAC	250 VAC
3 AMPS INDUCTIVE	3 AMPS INDUCTIVE	5 AMPS	5 AMPS
5 AMPS RESISTIVE	5 AMPS RESISTIVE		

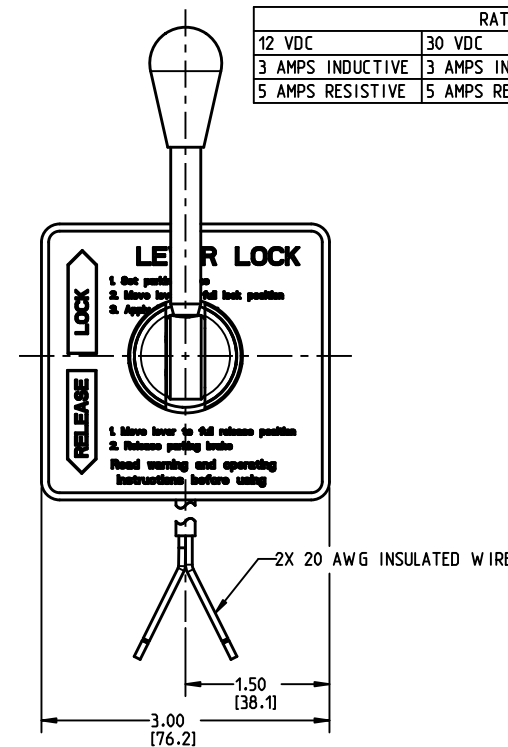

INCH
[MILLIMETER]

MICO[®]

North Mankato, Minnesota USA

COMPONENT AND SYSTEM RECOMMENDATIONS MADE BY MICO, INC ARE BASED ON INFORMATION SUPPLIED BY POTENTIAL USER AND/OR SYSTEM DESIGNER. THE POTENTIAL USER AND/OR DESIGNER MUST MAKE FINAL ACCEPTANCE AND APPROVAL OF COMPONENTS AND SYSTEM AFTER TESTING PERFORMANCE ON AN ACTUAL APPLICATION FOR WHICH SYSTEM WAS DESIGNED.

MICO, INC CLAIMS PROPRIETARY RIGHTS TO THE MATERIAL DISCLOSED IN THIS DOCUMENT. THIS DOCUMENT IS PROVIDED IN CONFIDENCE AND MAY NOT BE REPRODUCED OR DISCLOSED WITHOUT WRITTEN PERMISSION FROM MICO, INC. COPYRIGHT MICO, INC. ALL RIGHTS RESERVED.

SCALE 0.500	TITLE LEVER LOCK WITH PRESSURE SWITCH	SIZE A	DRAWING NUMBER 02-640-123	REV M
DWN JRA 2015-08-26	APVD PROD ENGRG DPD 2015-09-21		CUSTOMER COPY	3 5
X NO	APVD ENGRG BSW 2015-09-08			