

DRAWING NUMBER  
02-556-450  
NPI OR ECN NO  
ECN000575

30° INVOLUTE SPLINE-EXTERNAL  
13 TOOTH 16/32 PITCH  
FLAT ROOT, SIDE FIT, CLASS 5  
PER ANSI B92. 1-1970

PART NUMBER AND DATE CODE STAMPED  
ON COVER IN THIS APPROXIMATE AREA

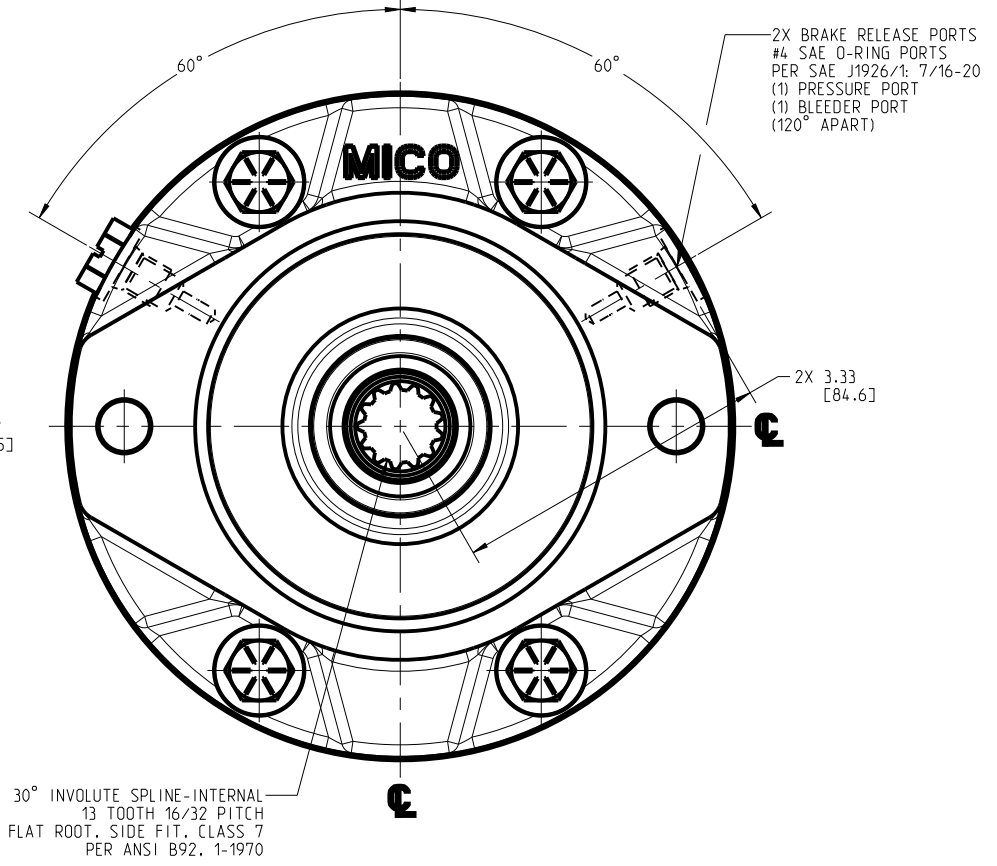
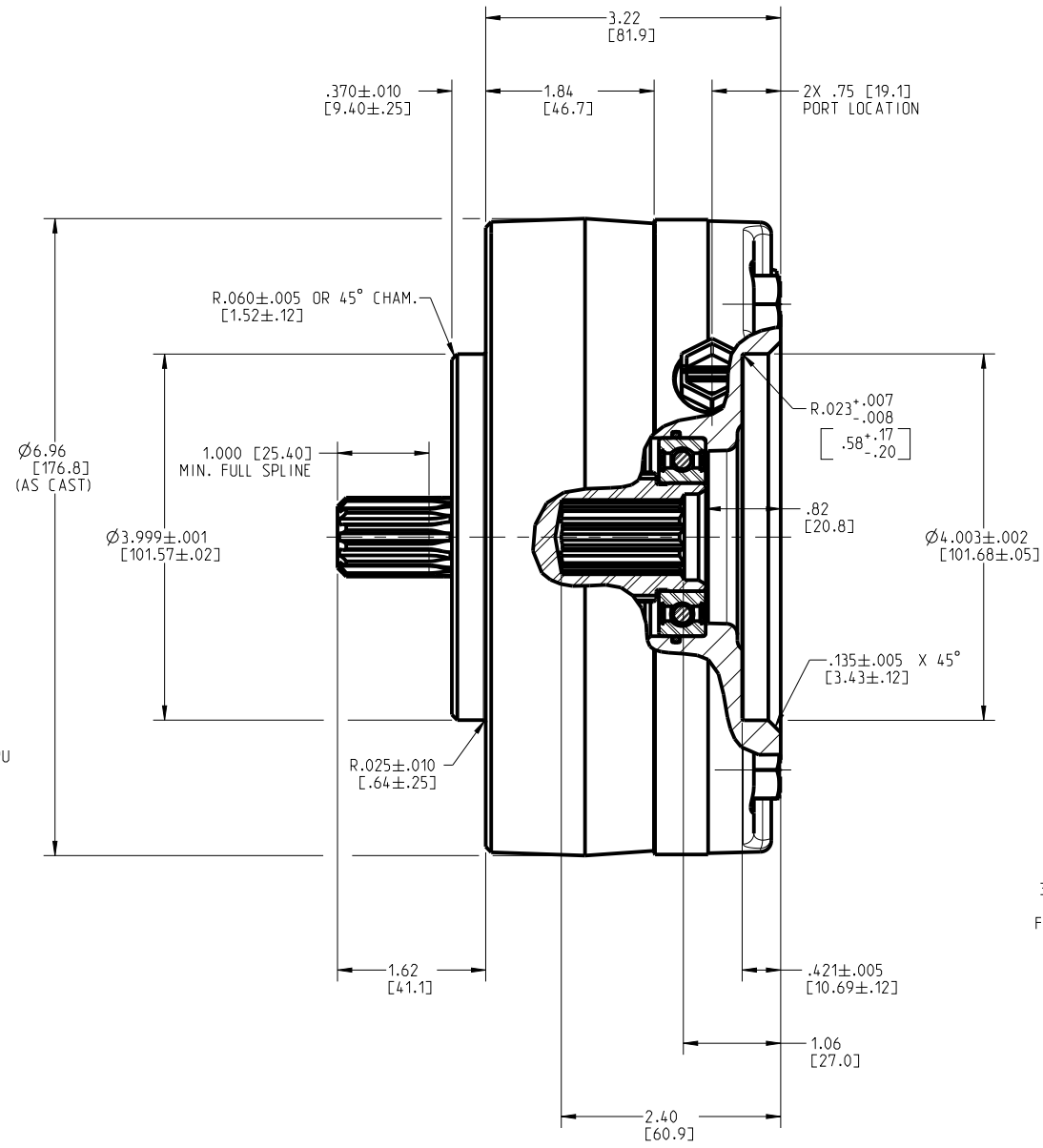
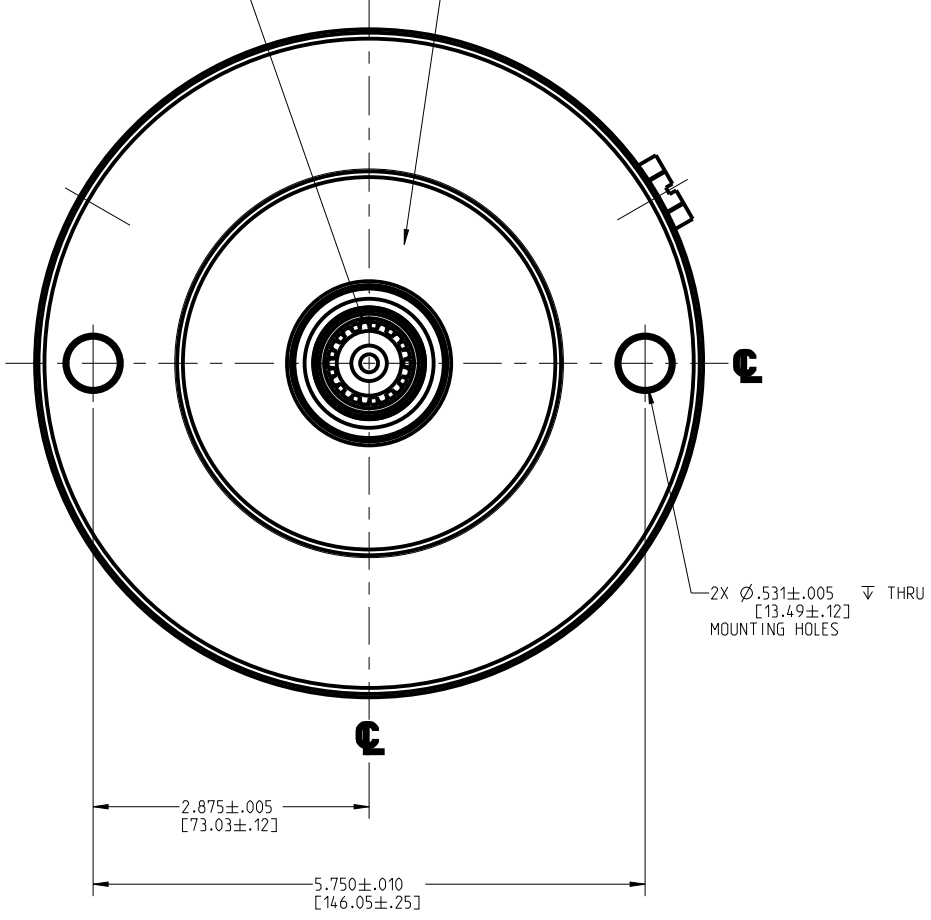

**NOTES:**

1. USE MINERAL BASE HYDRAULIC OIL ONLY FOR BRAKE RELEASE.
2. DIMENSIONS MAY VARY BETWEEN UNITS AND ARE FOR REFERENCE PURPOSES ONLY. MILLIMETER VALUES MAY NOT BE AN EXACT CONVERSION OF INCH VALUES.
3. LINING REPAIR KIT P/N 20-060-100
4. BEARING REPAIR KIT P/N 02-500-160
5. O-RING REPAIR KIT P/N 02-500-163
6. SPRING REPAIR KIT P/N 12-501-518
7. STACK ARRANGEMENT: ROTOR/STATOR/ROTOR/STATOR
8. BRAKE SURFACE COATING: GREY GLOSSY POLYURETHANE PAINT.
9. SPRING COMBINATION: 8 RED SPRINGS
10. RECOMMENDED CASE OIL: CHEVRON DELO GEAR LUBRICANT ESI SAE 80W-90. GEAR LUBRICANTS CONTAINING SULFUR-PHOSPHORUS BASED EP ADDITIVES SHOULD BE AVOIDED DUE TO LONG TERM EFFECTS ON FRICTION MATERIAL.

**SPECIFICATIONS:**

TYPE: WET MULTIPLE DISC BRAKE, SPRING APPLY, HYDRAULIC RELEASE.

MAXIMUM SPEED:	4,000 RPM SHAFT SPEED CAPABILITY SPECIFIED IS FOR BRAKE IN RELEASED CONDITION. ENERGY ABSORPTION DURING APPLY CYCLE MUST BE CAREFULLY EXAMINED FOR EACH APPLICATION.
RELEASE PRESSURE:	200 PSI INITIAL, 240 PSI FULL, 3,000 PSI MAX.
LINING MATERIAL:	SINTERED BRONZE
TORQUE RATING:	1,600 LBIN STATIC (BREAKAWAY) AT 0 PSI BACK PRESSURE. ACTUAL TORQUE MAY VARY BY UP TO 10% DUE TO MANUFACTURING TOLERANCES.
VOLUME OF OIL REQUIRED: TO RELEASE BRAKE	0.5 IN. <sup>3</sup> MIN., 0.9 IN. <sup>3</sup> MAX.
APPROXIMATE WEIGHT:	25 LB

INCH  
[MILLIMETER]

<b>MICO</b> North Mankato, Minnesota USA				
SCALE 0.500	TITLE SLMB-131324-BZ MULTIPLE DISC BRAKE			
DWN SHYPO 2014-10-08	APVD PROD ENGRG PJS 2015-01-28	SIZE B	DRAWING NUMBER 02-556-450	REV F
X NO	APVD ENGRG RV 10-09-2014	B	CUSTOMER COPY	1

COMPONENT AND SYSTEM RECOMMENDATIONS MADE BY MICO, INC ARE BASED ON INFORMATION SUPPLIED BY POTENTIAL USER AND/OR SYSTEM DESIGNER. THE POTENTIAL USER AND/OR DESIGNER MUST MAKE FINAL ACCEPTANCE AND APPROVAL OF COMPONENTS AND SYSTEM AFTER TESTING PERFORMANCE ON AN ACTUAL APPLICATION FOR WHICH SYSTEM WAS DESIGNED.

MICO, INC CLAIMS PROPRIETARY RIGHTS TO THE MATERIAL DISCLOSED IN THIS DOCUMENT. THIS DOCUMENT IS PROVIDED IN CONFIDENCE AND MAY NOT BE REPRODUCED OR DISCLOSED WITHOUT WRITTEN PERMISSION FROM MICO, INC. COPYRIGHT MICO, INC. ALL RIGHTS RESERVED.