

DRAWING NUMBER  
02-556-422  
NPI OR ECN NO  
ECN000562

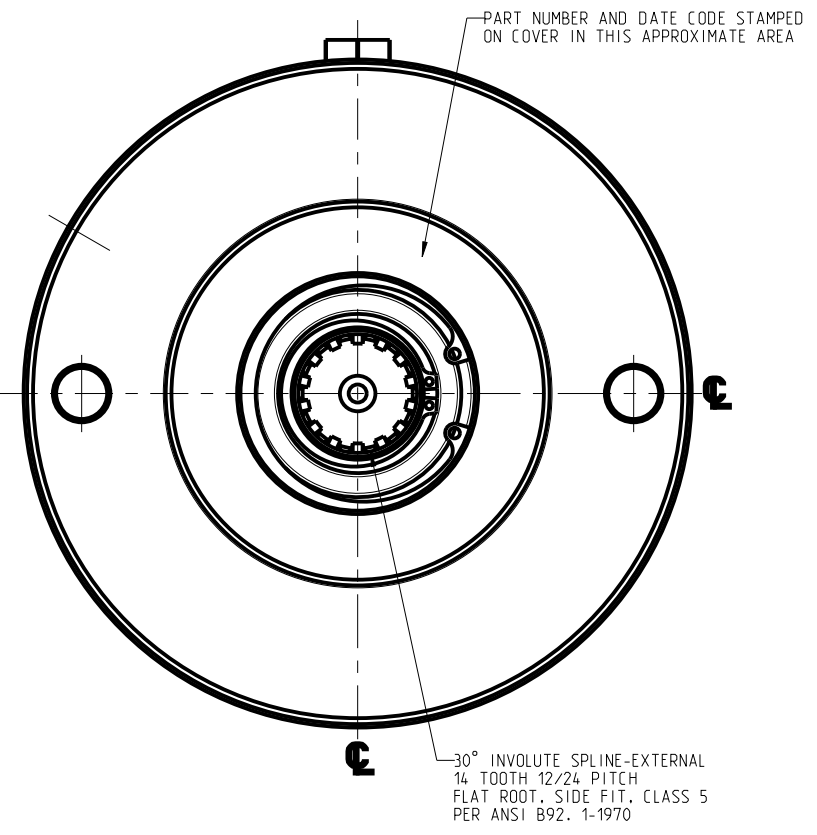
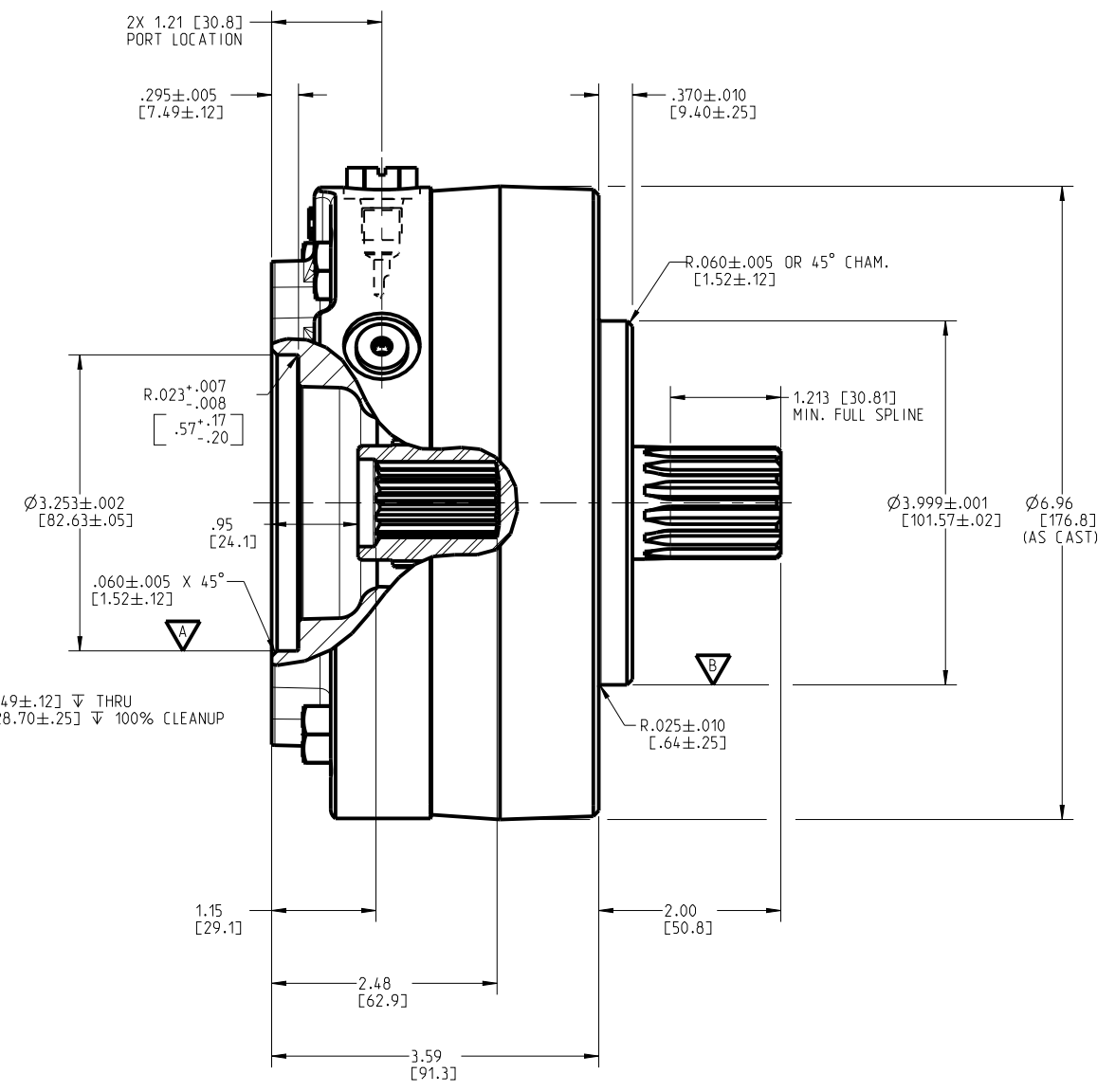
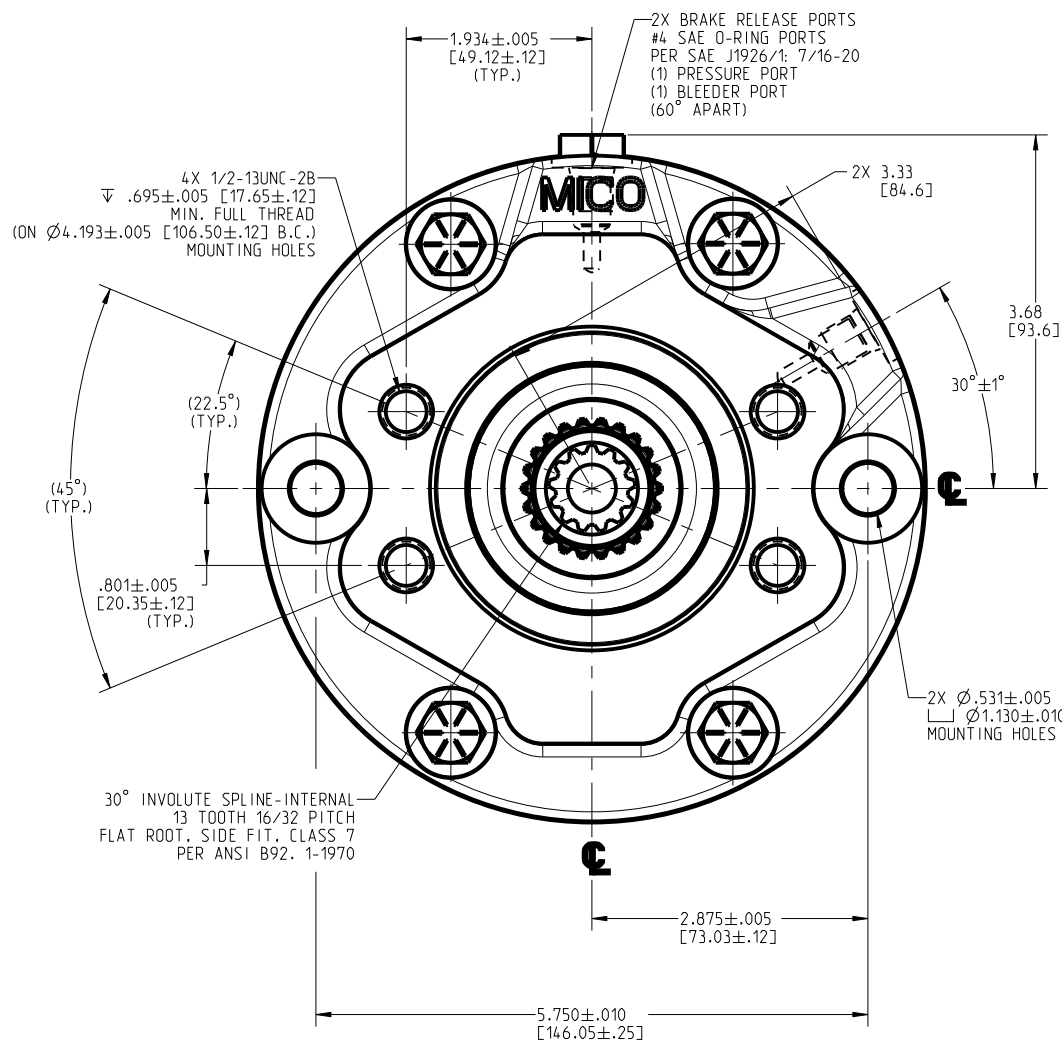

- NOTES:**
- FOR USE MINERAL BASE HYDRAULIC OIL ONLY FOR BRAKE RELEASE.
  - DIMENSIONS MAY VARY BETWEEN UNITS AND ARE FOR REFERENCE PURPOSES ONLY. MILLIMETER VALUES MAY NOT BE AN EXACT CONVERSION OF INCH VALUES
  - REPAIR KIT P/N 12-501-420
  - SURFACES **A** & **B** TO BE FREE OF PAINT

**SPECIFICATIONS:**

TYPE: DRY MULTIPLE DISC BRAKE. SPRING APPLY, HYDRAULIC RELEASE.

MAXIMUM SPEED: 4,000 RPM SHAFT SPEED CAPABILITY SPECIFIED IS FOR BRAKE IN RELEASED CONDITION. ENERGY ABSORPTION DURING APPLY CYCLE MUST BE CAREFULLY EXAMINED FOR EACH APPLICATION.

TORQUE RATING: 6,000 LBIN STATIC (BREAKAWAY) ACTUAL TORQUE MAY VARY BY UP TO 10% DUE TO MANUFACTURING TOLERANCES.

RELEASE PRESSURE: 335 PSI INITIAL, 400 PSI FULL & 3,000 PSI MAX.

VOLUME OF OIL REQUIRED TO RELEASE BRAKE: 0.5 IN<sup>3</sup> MIN., 0.9 IN<sup>3</sup> MAX.

LINING MATERIAL: SINTERED BRONZE

APPROXIMATE WEIGHT: 23 LB

INCH  
[MILLIMETER]

**MICO**<sup>®</sup>  
North Mankato, Minnesota USA

SCALE 0.500	TITLE LMB-141360-M MULTIPLE DISC BRAKE	SIZE B	DRAWING NUMBER 02-556-422	REV F
DWNSHYPO 2014-05-06	APVD PROD ENGRG PJS 2014-07-16		CUSTOMER COPY	
X NO	APVD ENGRG BLF 2014-06-10			

COMPONENT AND SYSTEM RECOMMENDATIONS MADE BY MICO, INC ARE BASED ON INFORMATION SUPPLIED BY POTENTIAL USER AND/OR SYSTEM DESIGNER. THE POTENTIAL USER AND/OR DESIGNER MUST MAKE FINAL ACCEPTANCE AND APPROVAL OF COMPONENTS AND SYSTEM AFTER TESTING PERFORMANCE ON AN ACTUAL APPLICATION FOR WHICH SYSTEM WAS DESIGNED.

MICO, INC CLAIMS PROPRIETARY RIGHTS TO THE MATERIAL DISCLOSED IN THIS DOCUMENT. THIS DOCUMENT IS PROVIDED IN CONFIDENCE AND MAY NOT BE REPRODUCED OR DISCLOSED WITHOUT WRITTEN PERMISSION FROM MICO, INC. COPYRIGHT MICO, INC. ALL RIGHTS RESERVED.