

PART NUMBER AND DATE CODE STAMPED ON COVER IN THIS APPROXIMATE AREA

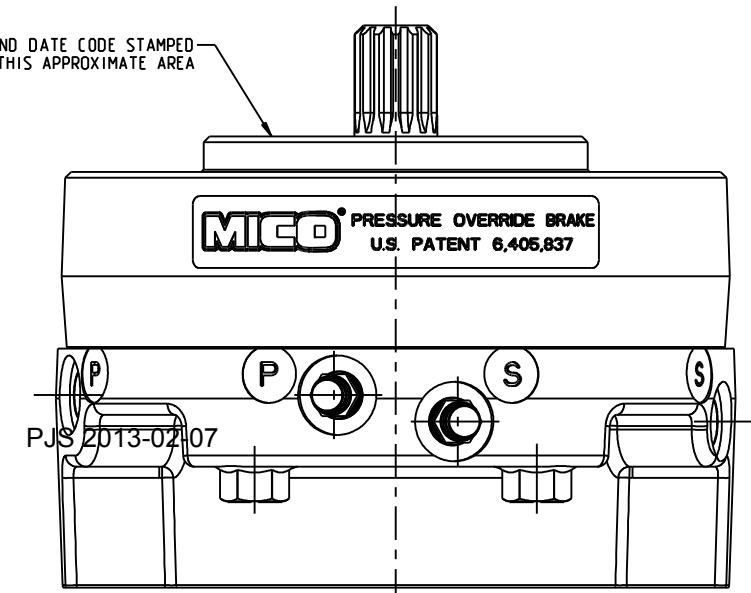

VIEW A-A

NOTES:
1. USE MINERAL BASE HYDRAULIC OIL ONLY FOR BRAKE RELEASE
2. DIMENSIONS MAY VARY BETWEEN UNITS AND ARE FOR REFERENCE PURPOSES ONLY
MILLIMETER VALUES MAY NOT BE EXACT CONVERSION OF INCH VALUES
3. REPAIR KIT P/N 12-501-399

SPECIFICATIONS:

TYPE:	MULTIPLE DISC BRAKE, SPRING APPLY HYDRAULIC RELEASE (WITH PRESSURE OVERRIDE)
FAILSAFE SECTION: TORQUE RATING:	1,500 LBIN STATIC (BREAKAWAY) AT 0 PSI BACK PRESSURE ACTUAL TORQUE MAY VARY BY UP TO 10% DUE TO MANUFACTURING TOLERANCES.
SERVICE OVERRIDE SECTION: TORQUE RATING:	1,600 LBIN @ 600 PSI ACTUAL TORQUE MAY VARY BY UP TO 10% DUE TO MANUFACTURING TOLERANCES.
MAXIMUM INPUT PRESSURE:	1,000 PSI
MAXIMUM SPEED:	3,000 RPM, HOWEVER, MAXIMUM SPEED AT TIME OF SERVICE APPLY IS DEPENDENT ON PRODUCT APPLICATION
RELEASE PRESSURE:	105 PSI INITIAL, 115 PSI FULL 3,000 PSI MAX. CONTINUOUS
LINING MATERIAL:	NON-ASBESTOS ORGANIC
VOLUME OF OIL REQUIRED TO: RELEASE BRAKE	0.75 IN ³ MIN., 0.95 IN ³ MAX.
APPROXIMATE WEIGHT:	26 LB

INCH
(MILLIMETER)

 North Mankato, Minnesota USA		SCALE	TITLE	SIZE	DRAWING NUMBER	REV
		0.500	PRESSURE OVERRIDE MULTIPLE DISC BRAKE	B	02-556-416	G
DWN RGS1 2013-01-07	APVD PROD ENGR PJS 2013-02-07	X NO	APVD ENGR RV 02/04/13	CUSTOMER COPY		

COMPONENT AND SYSTEM RECOMMENDATIONS MADE BY MICO, INC ARE BASED ON INFORMATION SUPPLIED BY POTENTIAL USER AND/OR SYSTEM DESIGNER. THE POTENTIAL USER AND/OR DESIGNER MUST MAKE FINAL ACCEPTANCE AND APPROVAL OF COMPONENTS AND SYSTEM AFTER TESTING PERFORMANCE ON AN ACTUAL APPLICATION FOR WHICH SYSTEM WAS DESIGNED.

MICO, INC CLAIMS PROPRIETARY RIGHTS TO THE MATERIAL DISCLOSED IN THIS DOCUMENT. THIS DOCUMENT IS PROVIDED IN CONFIDENCE AND MAY NOT BE REPRODUCED OR DISCLOSED WITHOUT WRITTEN PERMISSION FROM MICO, INC. COPYRIGHT MICO, INC. ALL RIGHTS RESERVED.