

- NOTES:**
1. USE MINERAL BASE HYDRAULIC OIL ONLY FOR BRAKE RELEASE.
 2. DIMENSIONS MAY VARY BETWEEN UNITS AND ARE FOR REFERENCE PURPOSES ONLY. MILLIMETER VALUES MAY NOT BE AN EXACT CONVERSION OF INCH VALUES.
 3. REPAIR KIT P/N 12-501-399

SPECIFICATIONS:

TYPE:	MULTIPLE DISC BRAKE, SPRING APPLY HYDRAULIC RELEASE. (WITH PRESSURE OVERRIDE)
FAILSAFE SECTION: TORQUE RATING:	3,000 LBIN STATIC (BREAKAWAY) AT 0 PSI BACK PRESSURE ACTUAL TORQUE MAY VARY BY UP TO 10% DUE TO MANUFACTURING TOLERANCES.
RELEASE PRESSURE:	180 PSI INITIAL, 200 PSI FULL 3,000 PSI MAX. CONTINUOUS
SERVICE OVERRIDE SECTION: TORQUE RATING:	1,600 LBIN @ 600 PSI ACTUAL TORQUE MAY VARY BY UP TO 10% DUE TO MANUFACTURING TOLERANCES.
MAXIMUM INPUT PRESSURE:	1,000 PSI
MAXIMUM SPEED:	3,000 RPM. HOWEVER, MAXIMUM SPEED AT TIME OF SERVICE APPLY IS DEPENDENT ON PRODUCT APPLICATION.
LINING MATERIAL:	NON-ASBESTOS ORGANIC
VOLUME OF OIL REQUIRED TO RELEASE BRAKE	0.75 IN ³ MIN., 0.95 IN ³ MAX.
APPROXIMATE WEIGHT:	26 LB

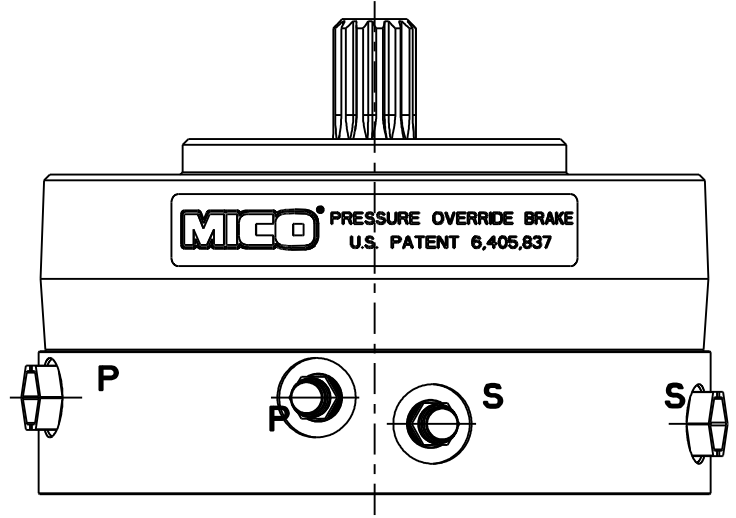

VIEW A-A

INCH
(MILLIMETER)

COMPONENT AND SYSTEM RECOMMENDATIONS MADE BY MICO, INC ARE BASED ON INFORMATION SUPPLIED BY POTENTIAL USER AND/OR SYSTEM DESIGNER. THE POTENTIAL USER AND/OR DESIGNER MUST MAKE FINAL ACCEPTANCE AND APPROVAL OF COMPONENTS AND SYSTEM AFTER TESTING PERFORMANCE ON AN ACTUAL APPLICATION FOR WHICH SYSTEM WAS DESIGNED.

MICO, INC CLAIMS PROPRIETARY RIGHTS TO THE MATERIAL DISCLOSED IN THIS DOCUMENT. THIS DOCUMENT IS PROVIDED IN CONFIDENCE AND MAY NOT BE REPRODUCED OR DISCLOSED WITHOUT WRITTEN PERMISSION FROM MICO, INC. COPYRIGHT MICO, INC. ALL RIGHTS RESERVED.

<p>North Mankato, Minnesota USA</p>		PRESSURE OVERRIDE MULTIPLE DISC BRAKE		
		SCALE 0.500	TITLE	REV
DWN RGS1 2013-01-07	APVD PROD ENGRG PJS 2013-02-26	SIZE B	DRAWING NUMBER 02-556-400	L
X NO	APVD ENGRG RV 02/04/13		CUSTOMER COPY	1