

DRAWING NUMBER
02-556-396
NPI OR ECN NO
ECN000289

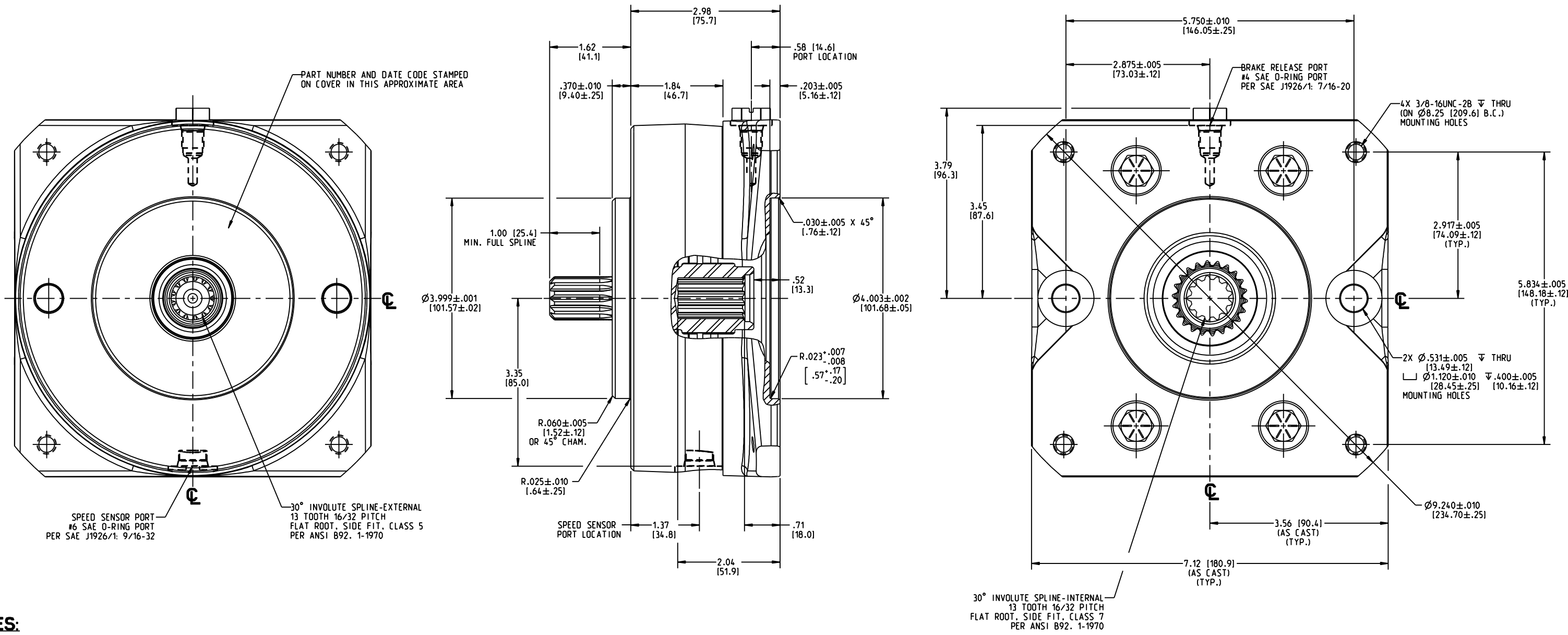

NOTES:

1. FOR USE WITH MINERAL BASE HYDRAULIC OIL ONLY
2. DIMENSIONS MAY VARY BETWEEN UNITS AND ARE FOR REFERENCE PURPOSES ONLY
MILLIMETER VALUES MAY NOT BE EXACT CONVERSION OF INCH VALUES
3. REPAIR KIT P/N 12-501-389
4. BRAKE SURFACE COATING: BLACK SEMI GLOSS ACRYLIC PRIMER

SPECIFICATIONS:

TYPE:	DRY MULTIPLE DISC BRAKE, SPRING APPLY, HYDRAULIC RELEASE
MAXIMUM SPEED:	4,000 RPM SHAFT SPEED CAPABILITY SPECIFIED IS FOR BRAKE IN RELEASED CONDITION. ENERGY ABSORPTION DURING APPLY CYCLE MUST BE CAREFULLY EXAMINED FOR EACH APPLICATION.
TORQUE RATING:	1,300 LBIN STATIC/DYNAMIC AT 0 PSI BACK PRESSURE ACTUAL TORQUE MAY VARY BY UP TO 10% DUE TO MANUFACTURING TOLERANCES.
RELEASE PRESSURE:	165 PSI INITIAL, 200 PSI FULL & 3,000 PSI MAX.
LINING MATERIAL:	NON-METALLIC
VOLUME OF OIL REQUIRED: TO RELEASE BRAKE	0.5 IN ³ MIN., 0.9 IN ³ MAX.
APPROXIMATE WEIGHT:	24.5 LB

INCH
[MILLIMETER]

COMPONENT AND SYSTEM RECOMMENDATIONS MADE BY MICO, INC ARE BASED ON INFORMATION SUPPLIED BY POTENTIAL USER AND/OR SYSTEM DESIGNER. THE POTENTIAL USER AND/OR DESIGNER MUST MAKE FINAL ACCEPTANCE AND APPROVAL OF COMPONENTS AND SYSTEM AFTER TESTING PERFORMANCE ON AN ACTUAL APPLICATION FOR WHICH SYSTEM WAS DESIGNED.

MICO, INC CLAIMS PROPRIETARY RIGHTS TO THE MATERIAL DISCLOSED IN THIS DOCUMENT. THIS DOCUMENT IS PROVIDED IN CONFIDENCE AND MAY NOT BE REPRODUCED OR DISCLOSED WITHOUT WRITTEN PERMISSION FROM MICO, INC. COPYRIGHT MICO, INC. ALL RIGHTS RESERVED.

MICO[®]
North Mankato, Minnesota USA

SCALE 0.500	TITLE SLMB-131313-NS MULTIPLE DISC BRAKE	SIZE B	DRAWING NUMBER 02-556-396	REV J
DWN RGBSI 2013-03-20	APVD PROD ENGRG PJS 2013-06-20		CUSTOMER COPY	
X NO	APVD ENGRG RV 04/22/2013			