

30° INVOLUTE SPLINE-EXTERNAL
13 TOOTH 16/32 PITCH
FLAT ROOT, SIDE FIT, CLASS 5
PER ANSI B92. 1-1970

PART NUMBER AND DATE CODE STAMPED
ON COVER IN THIS APPROXIMATE AREA

30° INVOLUTE SPLINE-INTERNAL
13 TOOTH 16/32 PITCH
FLAT ROOT, SIDE FIT, CLASS 7
PER ANSI B92. 1-1970

BRAKE RELEASE PORT
#4 SAE O-RING PORT
PER SAE J1926/1: 7/16-20

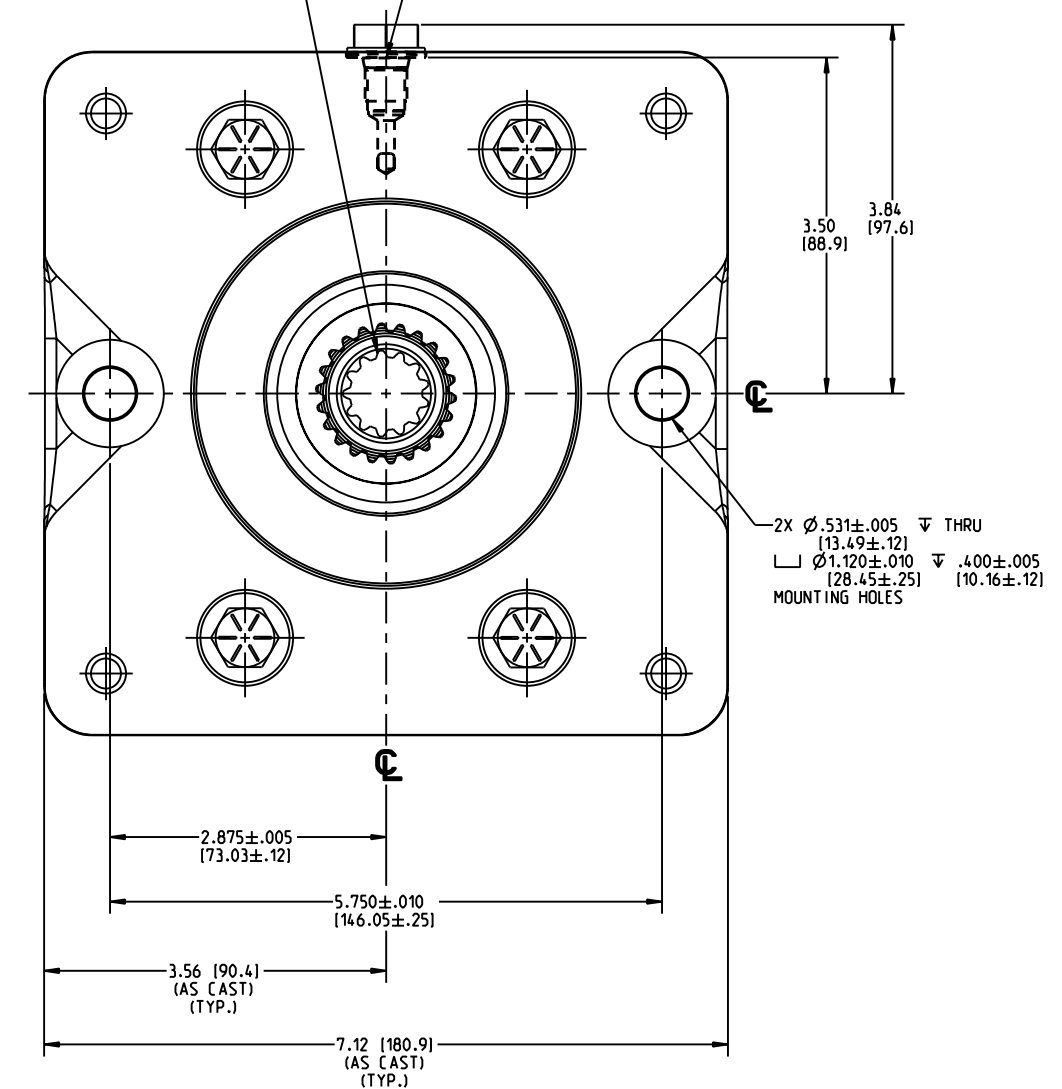
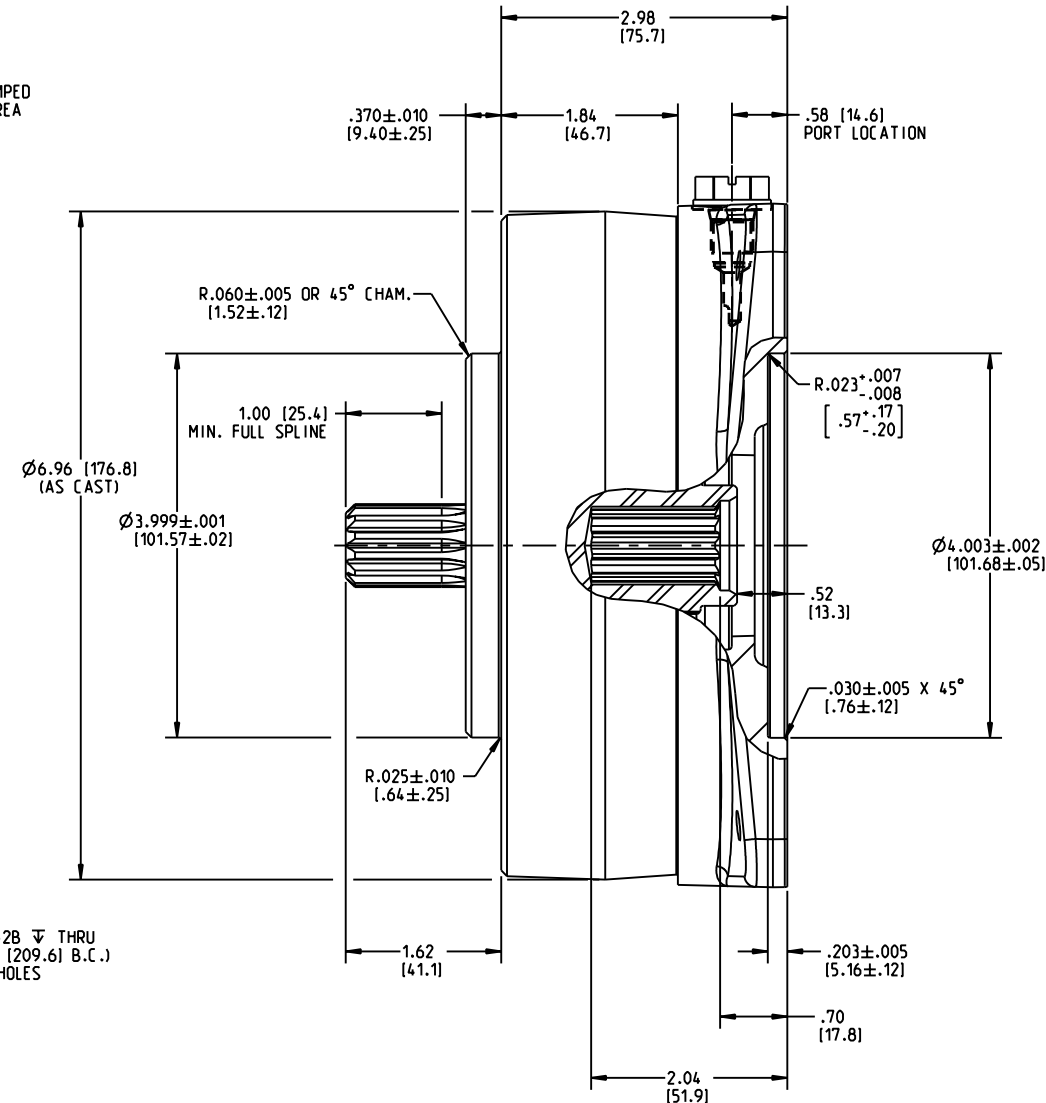
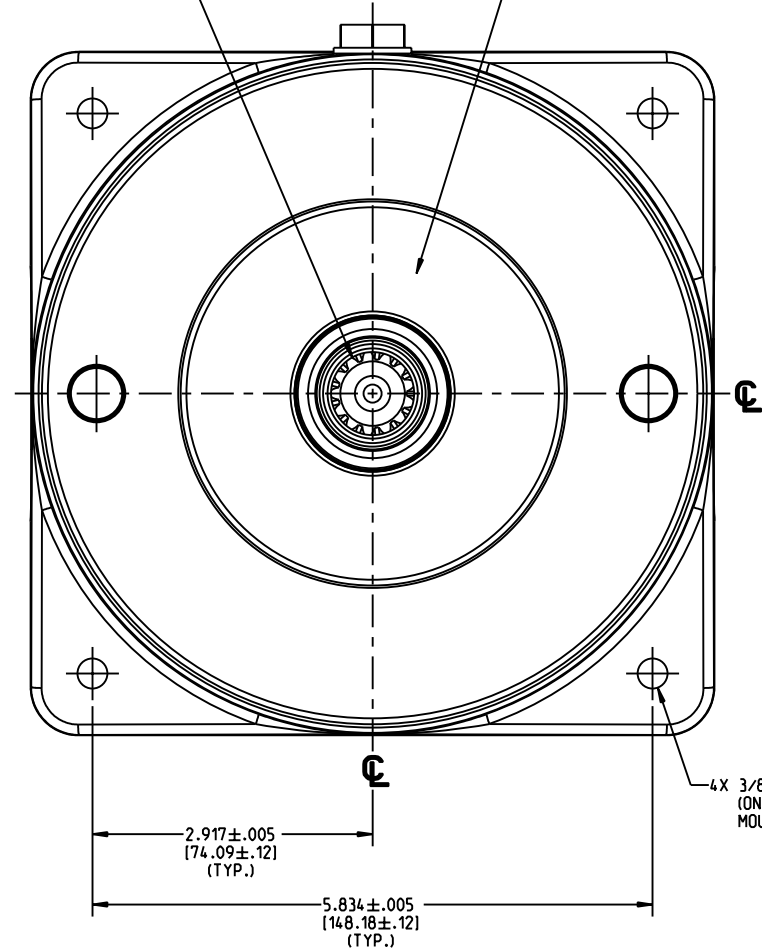

NOTES:

1. FOR USE WITH MINERAL BASE HYDRAULIC OIL ONLY
2. DIMENSIONS MAY VARY BETWEEN UNITS AND ARE FOR REFERENCE PURPOSES ONLY
MILLIMETER VALUES MAY NOT BE AN EXACT CONVERSION OF INCH VALUES
3. LINING REPAIR KIT P/N 20-060-100
4. BEARING REPAIR KIT P/N 02-500-142
5. O-RING REPAIR KIT P/N 02-500-141
6. SPRING REPAIR KIT P/N 12-501-512
7. BRAKE SURFACE COATING: BLACK SEMI GLOSS ACRYLIC PRIMER
8. CUSTOMER RESPONSIBLE FOR SEALING MOUNTING INTERFACE
BETWEEN MOTOR AND BRAKE.

SPECIFICATIONS:

TYPE:	DRY MULTIPLE DISC BRAKE, SPRING APPLY, HYDRAULIC RELEASE
MAXIMUM SPEED:	4,000 RPM SHAFT SPEED CAPABILITY SPECIFIED IS FOR BRAKE IN RELEASED CONDITION. ENERGY ABSORPTION DURING APPLY CYCLE MUST BE CAREFULLY EXAMINED FOR EACH APPLICATION.
TORQUE RATING:	600 LBIN STATIC (BREAKAWAY) ACTUAL TORQUE MAY VARY BY UP TO 10% DUE TO MANUFACTURING TOLERANCES.
RELEASE PRESSURE:	105 PSI INITIAL, 125 PSI FULL & 3,000 PSI MAX.
LINING MATERIAL:	SINTERED BRONZE
VOLUME OF OIL REQUIRED: TO RELEASE BRAKE	0.5 IN ³ MIN., 0.9 IN ³ MAX.
APPROXIMATE WEIGHT:	24.5 LB

INCH
[MILLIMETER]

MICO[®]

North Mankato, Minnesota USA

COMPONENT AND SYSTEM RECOMMENDATIONS MADE BY MICO, INC ARE BASED ON INFORMATION SUPPLIED BY POTENTIAL USER AND/OR SYSTEM DESIGNER. THE POTENTIAL USER AND/OR DESIGNER MUST MAKE FINAL ACCEPTANCE AND APPROVAL OF COMPONENTS AND SYSTEM AFTER TESTING PERFORMANCE ON AN ACTUAL APPLICATION FOR WHICH SYSTEM WAS DESIGNED.

MICO, INC CLAIMS PROPRIETARY RIGHTS TO THE MATERIAL DISCLOSED IN THIS DOCUMENT. THIS DOCUMENT IS PROVIDED IN CONFIDENCE AND MAY NOT BE REPRODUCED OR DISCLOSED WITHOUT WRITTEN PERMISSION FROM MICO, INC. COPYRIGHT MICO, INC. ALL RIGHTS RESERVED.

SCALE 0.500	TITLE MULTIPLE DISC BRAKE	SIZE	DRAWING NUMBER	REV
DWN RGBSI 2012-01-02	APVD PROD ENGRG PJS 2013-02-07	B	02-556-366	F
X NO	APVD ENGRG RV 01/07/12		CUSTOMER COPY	0