

7/16 NUT  
RECOMMENDED TORQUE IS 22 TO 27 LBFT

SEE SERVICE INSTRUCTIONS SUPPLIED  
WITH CALIPER BRAKE FOR PROPER  
ADJUSTMENT PROCEDURE.

NUT AND SCREW WILL BE  
SHIPPED UNASSEMBLED

RECOMMENDED TORQUE FOR  
BLEEDER SCREW IS 9 TO 15 LB-FT

LOCATION OF P/N  
AND DATE CODE

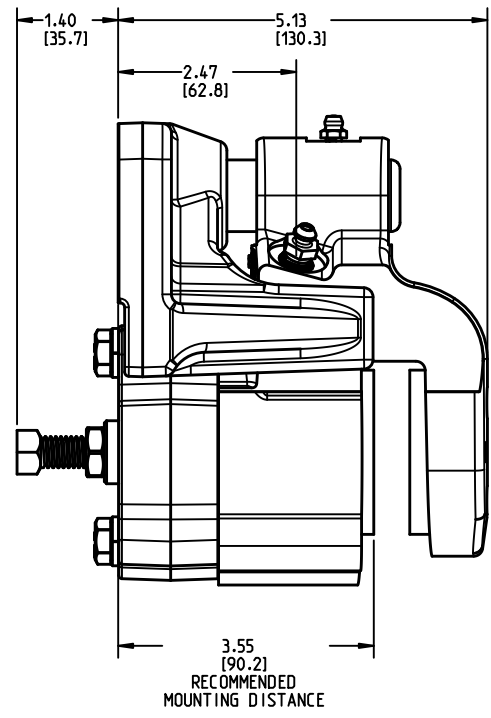

**OPTIONAL MOUNTING**  
SCALE 0.375

**NOTES:**

- 1) TO BE USED WITH MINERAL BASE HYDRAULIC OIL ONLY.
- 2) DIMENSIONS MAY VARY BETWEEN UNITS AND ARE TO BE USED FOR REFERENCE PURPOSES ONLY. MILLIMETER VALUES MAY NOT BE AN EXACT CONVERSION OF INCH VALUES.
- 3) SLOWLY APPLY GREASE THRU ZERK FITTING AFTER ASSEMBLY UNTIL GREASE IS OBSERVED EXITING SEALS. OVER PRESSURIZING MAY FORCE SEALS OUT OF HOUSING.
- 4) BRAKE SHOWN IN APPLIED POSITION.
- 5) SET SCREW AND NUT SHIPPED UNASSEMBLED TO BRAKE.
- 6) BRAKE SURFACE FINISH: ZINC CHROMATE YELLOW PER ATSM B633, TYPE II .SC2.
- 7) LINING MATERIAL: NON-ASBETOS, LEAD FREE.
- 8) SEAL KIT P/N 02-500-058.
- 9) REPAIR KIT P/N 02-500-244.
- 10) LINING KIT P/N 20-060-121.

**PERFORMANCE CHARACTERISTICS:**

- 1) BRAKE TORQUE: Bt (LBIN) = 3840 X (DISC RADIUS - 1.18).
- 2) MAXIMUM TORQUE ACHIEVED ONLY AFTER BRAKE HAS BEEN PROPERLY ADJUSTED AND BURNISHED.
- 3) COMPLETE RETRACTION PRESSURE: 1500 PSI.
- 4) MAXIMUM CONTINUOUS DUTY PRESSURE IS 2000 PSI.
- 5) MAXIMUM INTERMITTENT DUTY PRESSURE IS 2500 PSI.
- 6) VOLUME REQUIRED FOR COMPLETE RETRACTION: .80 CUIN.
- 7) CAUTION: DISC RUBBING SPEED SHOULD NOT EXCEED 5000 FT/MIN.
- 8) "A" DIMENSION = DISC RADIUS + 1.62 (DISC DIA. FROM 9 TO 15 INCHES).  
"A" DIMENSION = DISC RADIUS + 1.75 (DISC DIA. GREATER THAN 15 INCHES).

**INCH  
(MILLIMETER)**

<b>MICO</b> North Mankato, Minnesota USA		SCALE 1.000		TITLE SPRING BRAKE	
DWN JJH 2015-11-24	APVD PROD ENGRG PJS 2015-11-30	SIZE B	DRAWING NUMBER 02-530-632	REV C 1	
X NO X07-1623-000	APVD ENGRG BSW 2015-11-24	CUSTOMER COPY			

COMPONENT AND SYSTEM RECOMMENDATIONS MADE BY MICO, INC ARE BASED ON INFORMATION SUPPLIED BY POTENTIAL USER AND/OR SYSTEM DESIGNER. THE POTENTIAL USER AND/OR DESIGNER MUST MAKE FINAL ACCEPTANCE AND APPROVAL OF COMPONENTS AND SYSTEM AFTER TESTING PERFORMANCE ON AN ACTUAL APPLICATION FOR WHICH SYSTEM WAS DESIGNED.

MICO, INC CLAIMS PROPRIETARY RIGHTS TO THE MATERIAL DISCLOSED IN THIS DOCUMENT. THIS DOCUMENT IS PROVIDED IN CONFIDENCE AND MAY NOT BE REPRODUCED OR DISCLOSED WITHOUT WRITTEN PERMISSION FROM MICO, INC. COPYRIGHT MICO, INC. ALL RIGHTS RESERVED.