

DRAWING NUMBER  
02-515-036  
NPI OR ECN NO  
ECN C000377

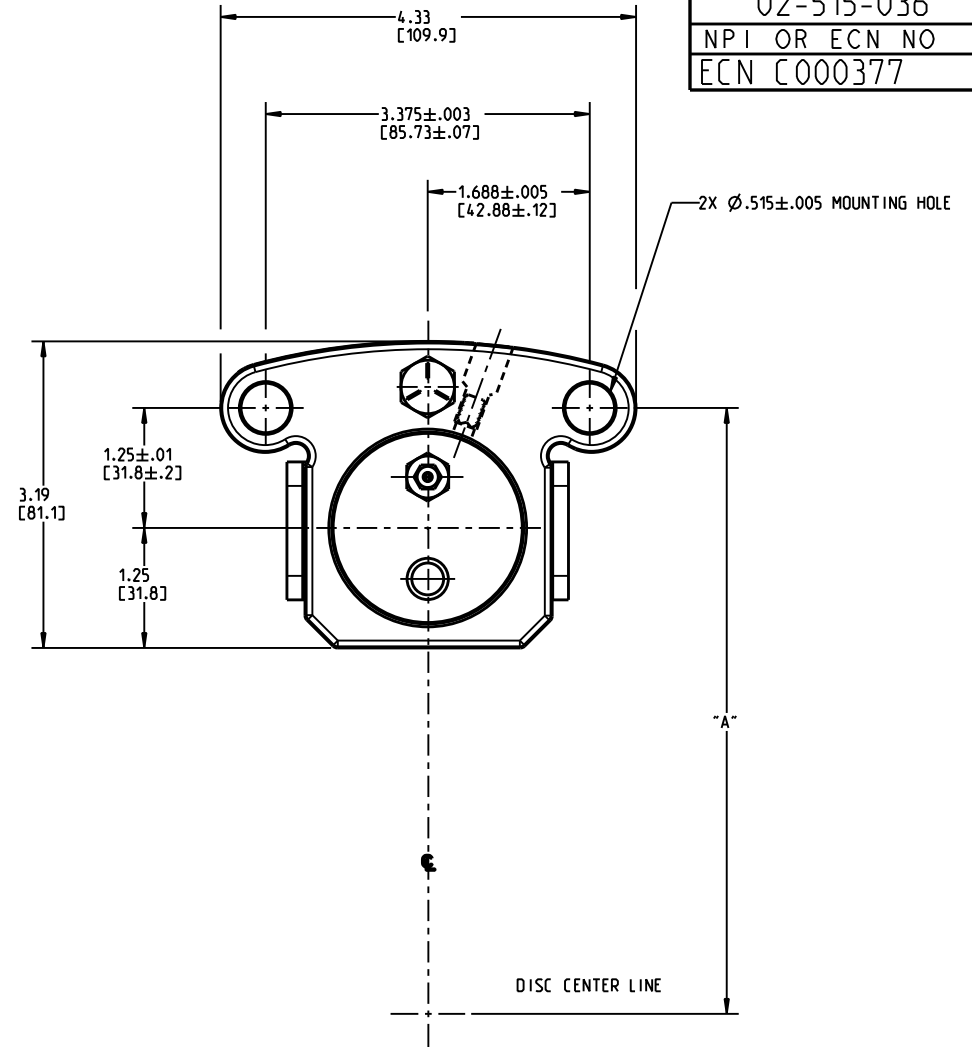
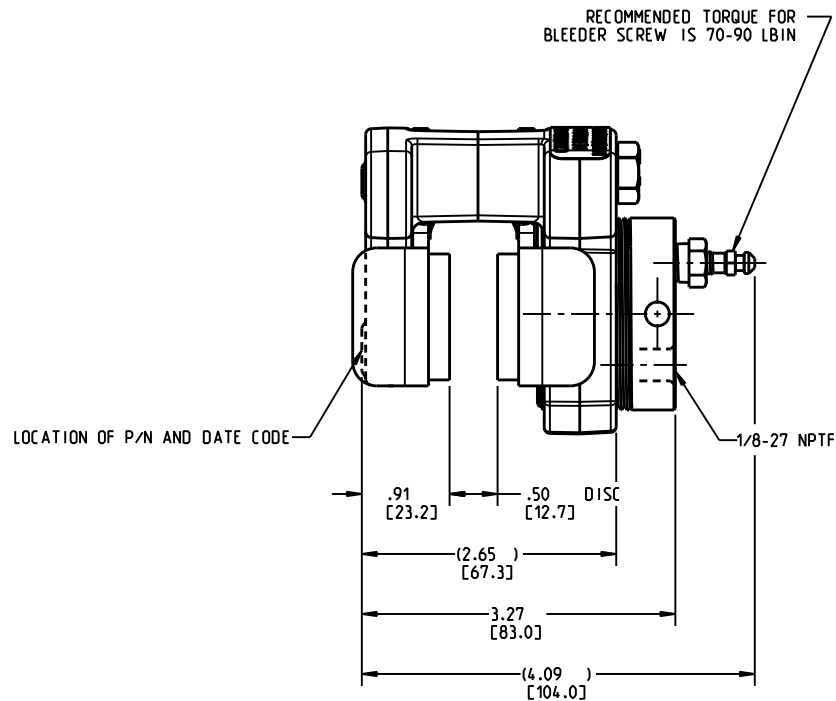

**NOTES:**

1. FOR USE WITH MINERAL BASE HYDRAULIC OIL ONLY.
2. DIMENSIONS MAY VARY BETWEEN UNITS AND ARE TO BE USED FOR REFERENCE PURPOSES ONLY. MILLIMETER VALUES MAY NOT BE AN EXACT CONVERSION OF INCH VALUES.
3. DISC DIAMETER: 6.00 TO UNLIMITED
4. DISC THICKNESS: .50
5. "A" DIMENSION = DISC RADIUS + .38
6. REPAIR KIT P/N 02-500-038.
7. LINING KIT P/N 20-060-063.

**PERFORMANCE CHARACTERISTICS:**

1. BRAKE TORQUE: Bt (LBIN) = PSI X 1.24 X (DISC RADIUS - 1).
2. CAUTION: CONTINUOUS DUTY PRESSURE-1500 PSI  
INTERMITTENT DUTY PRESSURE-2000 PSI
3. CAUTION: DISC RUBBING SPEED SHOULD NOT EXCEED 5000 FT./MIN.
4. 200 PSI MAX. BLEEDING PRESSURE.
5. MAXIMUM TORQUE ACHIEVED ONLY AFTER BRAKE HAS BEEN PROPERLY ADJUSTED AND BURNISHED.

COMPONENT AND SYSTEM RECOMMENDATIONS MADE BY MICO, INC ARE BASED ON INFORMATION SUPPLIED BY POTENTIAL USER AND/OR SYSTEM DESIGNER. THE POTENTIAL USER AND/OR DESIGNER MUST MAKE FINAL ACCEPTANCE AND APPROVAL OF COMPONENTS AND SYSTEM AFTER TESTING PERFORMANCE ON AN ACTUAL APPLICATION FOR WHICH SYSTEM WAS DESIGNED.

MICO, INC CLAIMS PROPRIETARY RIGHTS TO THE MATERIAL DISCLOSED IN THIS DOCUMENT. THIS DOCUMENT IS PROVIDED IN CONFIDENCE AND MAY NOT BE REPRODUCED OR DISCLOSED WITHOUT WRITTEN PERMISSION FROM MICO, INC. COPYRIGHT MICO, INC. ALL RIGHTS RESERVED.



SCALE 0.500	TITLE HYDRAULIC BRAKE			
DWN MAP 2009-11-11	APVD PROD ENGRG DPD 2010-01-12	SIZE A	DRAWING NUMBER 02-515-036	REV F
X NO	APVD ENGRG BSW 2009-12-31	CUSTOMER COPY		2 1