

Ø 520/.510 MOUNTING HOLE
2 PLACES

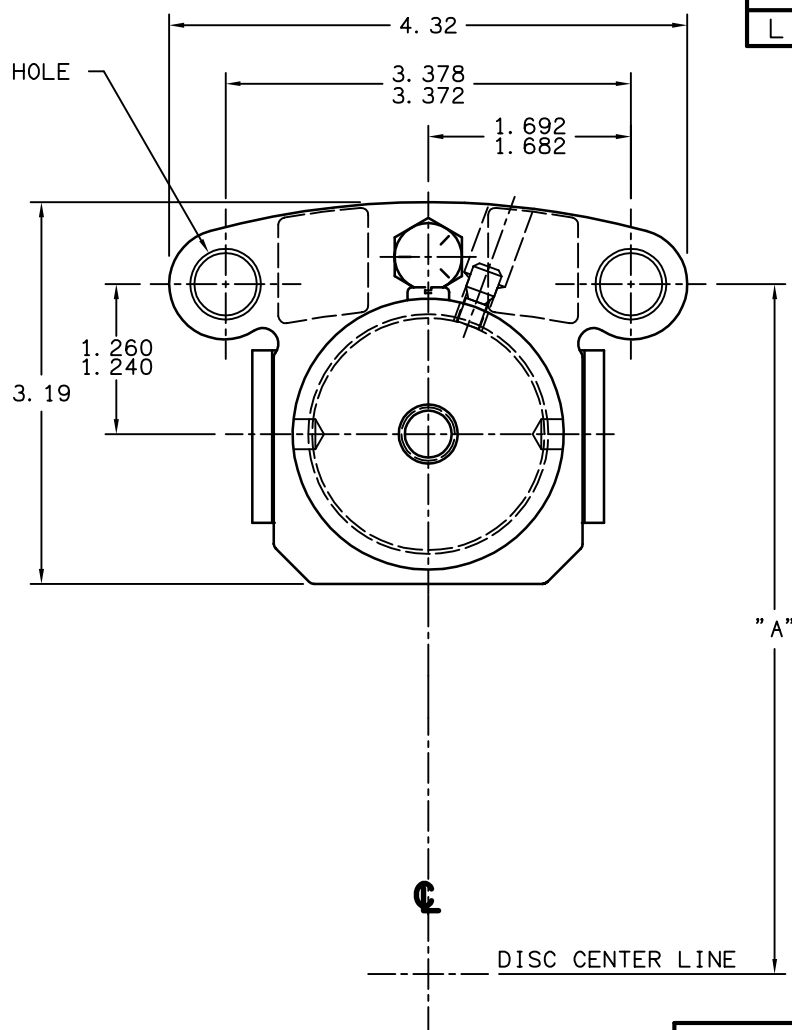
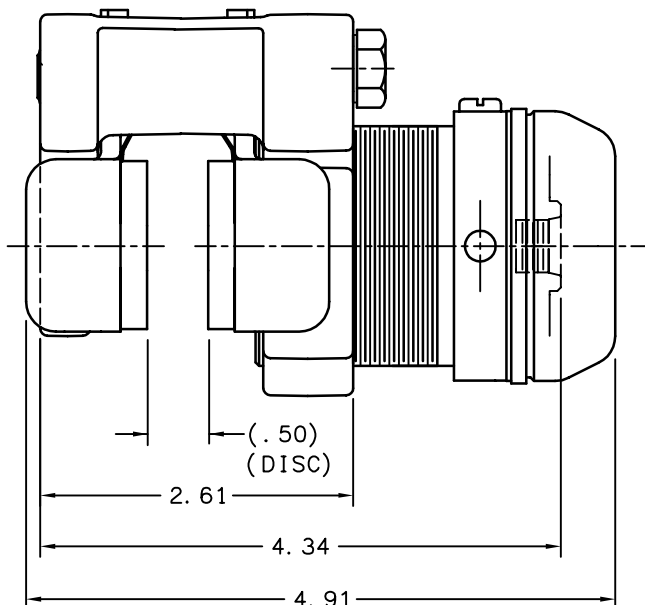

NOTES:

1. FOR USE WITH MINERAL BASE HYDRAULIC OIL ONLY.
2. DIMENSIONS WILL VARY SLIGHTLY BETWEEN UNITS AND ARE TO BE USED FOR REFERENCE PURPOSES ONLY.
3. DISC DIAMETER: 6.00 TO UNLIMITED
4. DISC THICKNESS: .50
5. "A" DIMENSION = DISC RADIUS + .38
6. SEAL KIT P/N 02-500-036.
7. REPAIR KIT P/N 02-500-189.
8. LINING KIT P/N 20-060-082.

PERFORMANCE CHARACTERISTICS:

1. BRAKE TORQUE: B_t (LBS-IN) = 680 X (DISC RADIUS -1.00).
2. RELEASE PRESSURE 700 PSI
3. **CAUTION-** CONTINUOUS DUTY PRESSURE-2000 PSI
INTERMITTENT DUTY PRESSURE-2500 PSI
4. **CAUTION-** DISC RUBBING SPEED SHOULD NOT EXCEED 5000 FT. /MIN.
IF BRAKE IS USED DYNAMICALLY.
5. 200 PSI MAX. BLEEDING PRESSURE.
6. MAXIMUM TORQUE ACHIEVED ONLY AFTER BRAKE HAS BEEN PROPERLY ADJUSTED AND BURNISHED.

COMPONENT AND SYSTEM RECOMMENDATIONS MADE BY MICO, INC. ARE BASED ON INFORMATION SUPPLIED BY POTENTIAL USER AND/OR SYSTEM DESIGNER. THE POTENTIAL USER AND/OR DESIGNER MUST MAKE FINAL ACCEPTANCE AND APPROVAL OF COMPONENTS AND SYSTEM AFTER TESTING PERFORMANCE ON AN ACTUAL APPLICATION FOR WHICH SYSTEM WAS DESIGNED.

 North Mankato, Minnesota U. S. A.					
SCALE	5/8	PART NUMBER	02-515-012	REV. L	
X NO.		CUSTOMER COPY			
DRAWN	LAM	CHECKED	SH	APPROVED	GA
REVISED	WHR	DATE	5-25-99	ENG.	5-26-99
		4-6-99			

MICO, INC. CLAIMS PROPRIETARY RIGHTS TO THE MATERIAL DISCLOSED IN THIS DOCUMENT. THIS DOCUMENT IS PROVIDED IN CONFIDENCE AND MAY NOT BE REPRODUCED OR DISCLOSED WITHOUT WRITTEN PERMISSION FROM MICO, INC. COPYRIGHT MICO, INC. ALL RIGHTS RESERVED.