

DRAWING NUMBER
02-460-127
NPI OR ECN NO
ECN B001124

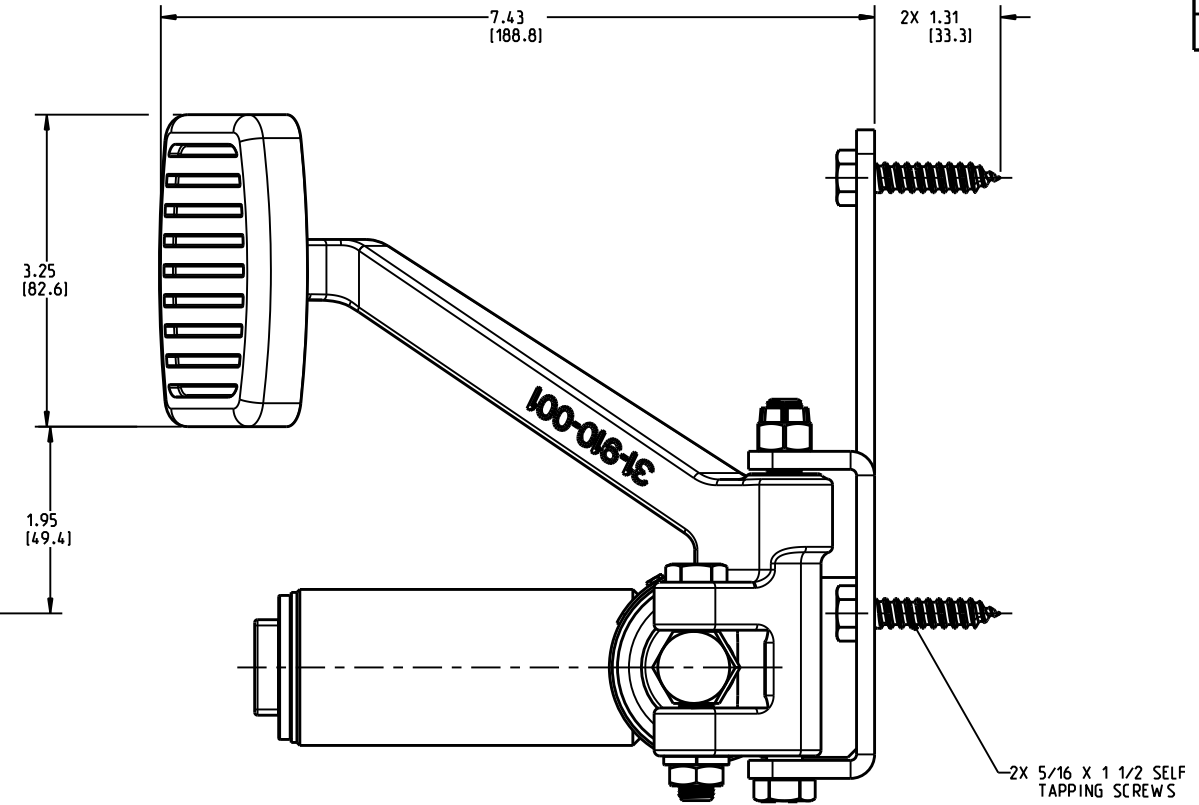
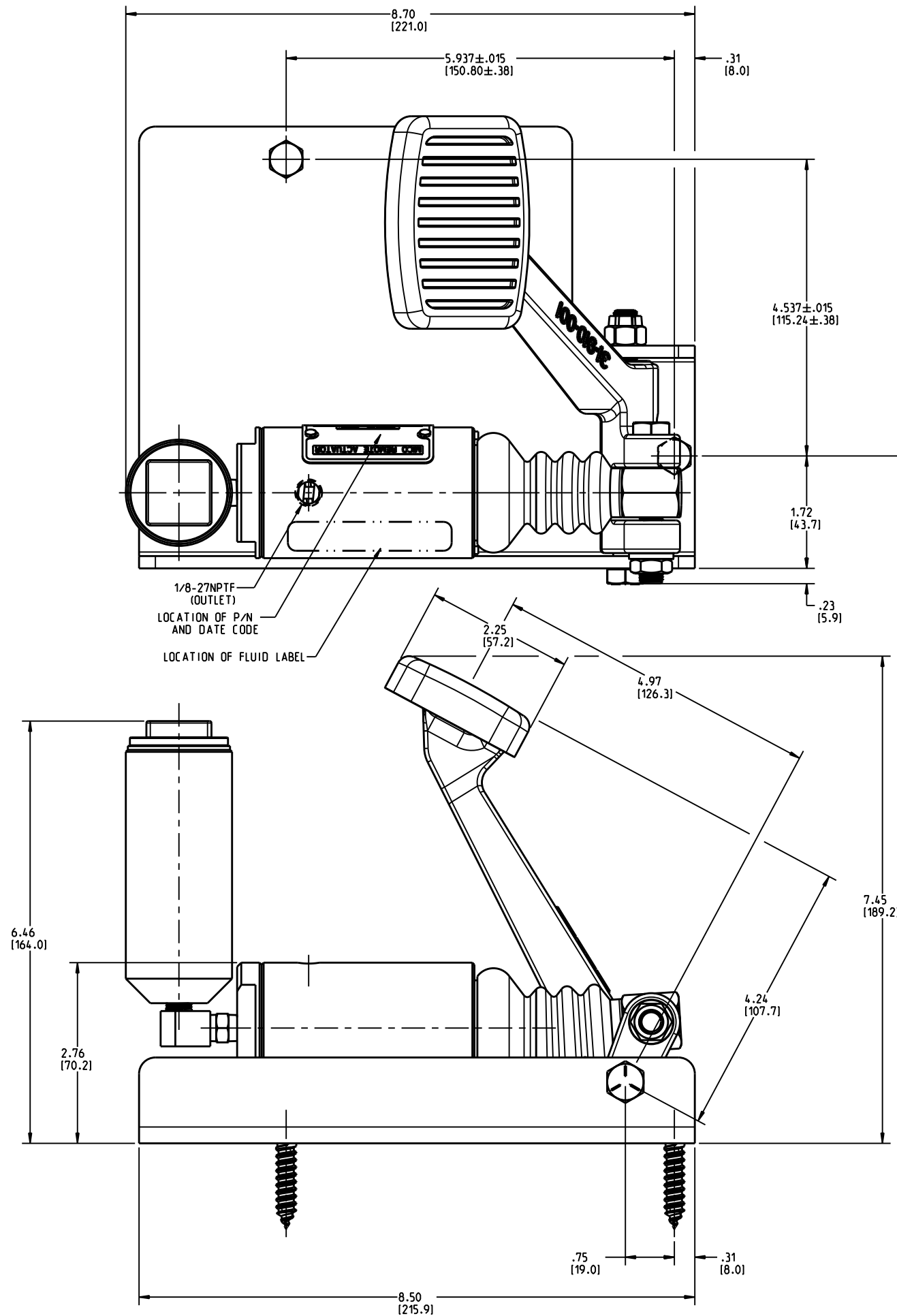

NOTES:

1. TO BE USED WITH DOT 3, 4 OR 5 BRAKE FLUID ONLY.
2. DIMENSIONS WITHOUT TOLERANCE MAY VARY BETWEEN UNITS AND ARE TO BE USED FOR REFERENCE PURPOSES ONLY. MILLIMETER VALUES MAY NOT BE AN EXACT CONVERSION OF INCH VALUES.
3. REPAIR KIT 02-400-066.
4. RESERVOIR SHIPPED UNASSEMBLED. RECOMMENDED INSTALLATION TORQUE: 84-96 LBIN.
5. SURFACE COATING: ZINC CHROMATE PER ASTM B633.

PERFORMANCE CHARACTERISTICS:

1. ACTUATOR:
PEDAL RATIO: 5:1
BORE: Ø1.125 IN
STROKE: 1.25 IN
EFFECTIVE DISPLACEMENT: 1.18 CUIN
2. RESERVOIR: 3.3 CUIN

INCH
(MILLIMETER)



COMPONENT AND SYSTEM RECOMMENDATIONS MADE BY MICO, INC ARE BASED ON INFORMATION SUPPLIED BY POTENTIAL USER AND/OR SYSTEM DESIGNER. THE POTENTIAL USER AND/OR DESIGNER MUST MAKE FINAL ACCEPTANCE AND APPROVAL OF COMPONENTS AND SYSTEM AFTER TESTING PERFORMANCE ON AN ACTUAL APPLICATION FOR WHICH SYSTEM WAS DESIGNED.

MICO, INC CLAIMS PROPRIETARY RIGHTS TO THE MATERIAL DISCLOSED IN THIS DOCUMENT. THIS DOCUMENT IS PROVIDED IN CONFIDENCE AND MAY NOT BE REPRODUCED OR DISCLOSED WITHOUT WRITTEN PERMISSION FROM MICO, INC. COPYRIGHT MICO, INC. ALL RIGHTS RESERVED.

SCALE 0.500	TITLE REMOTE ACTUATOR			
DWN ETM 2013-09-16	APVD PROD ENGRG DPD 2013-10-15	SIZE B	DRAWING NUMBER 02-460-127	REV K
X NO .	APVD ENGRG BSW 2013-10-01		CUSTOMER COPY	2 3