

DRAWING NUMBER
02-120-021
NPI OR ECN NO
ECN C000519

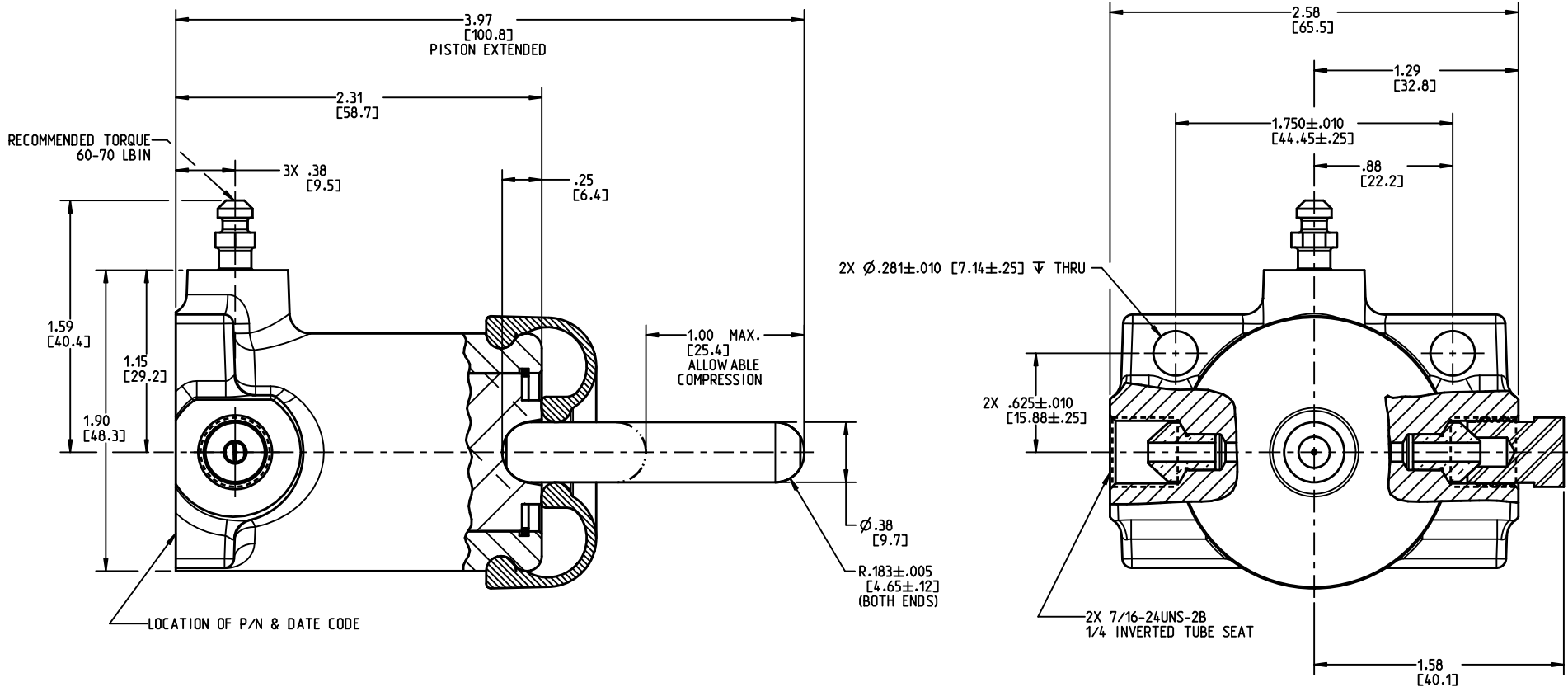

NOTES:

- 1) FOR USE WITH DOT 3, 4 OR 5 BRAKE FLUID ONLY.
- 2) DIMENSIONS MAY VARY SLIGHTLY BETWEEN UNITS AND ARE TO BE USED FOR REFERENCE PURPOSES ONLY. MILLIMETER VALUES MAY NOT BE AN EXACT CONVERSION OF INCH VALUES.
- 3) REPAIR KIT P/N 02-100-007.
- 4) FSN 2530-837-3176

PERFORMANCE CHARACTERISTICS:

- 1) BORE: $\varnothing 1.000$ IN. [25.4 mm]
- 2) STROKE: 1.00 IN. [25.4 mm]

INCH
[MILLIMETER]

COMPONENT AND SYSTEM RECOMMENDATIONS MADE BY MICO, INC ARE BASED ON INFORMATION SUPPLIED BY POTENTIAL USER AND/OR SYSTEM DESIGNER. THE POTENTIAL USER AND/OR DESIGNER MUST MAKE FINAL ACCEPTANCE AND APPROVAL OF COMPONENTS AND SYSTEM AFTER TESTING PERFORMANCE ON AN ACTUAL APPLICATION FOR WHICH SYSTEM WAS DESIGNED.

MICO, INC CLAIMS PROPRIETARY RIGHTS TO THE MATERIAL DISCLOSED IN THIS DOCUMENT. THIS DOCUMENT IS PROVIDED IN CONFIDENCE AND MAY NOT BE REPRODUCED OR DISCLOSED WITHOUT WRITTEN PERMISSION FROM MICO, INC. COPYRIGHT MICO, INC. ALL RIGHTS RESERVED.

MICO [®]				
North Mankato, Minnesota USA				
SCALE 1.000	TITLE SLAVE CYLINDER			
DWN SHYPO 2014-12-29	APVD PROD ENGRG DPD 2015-01-16	SIZE A	DRAWING NUMBER 02-120-021	REV K
X NO	APVD ENGRG BSW 2014-12-29		CUSTOMER COPY	5 6