

**INCH**  
**[MILLIMETER]**

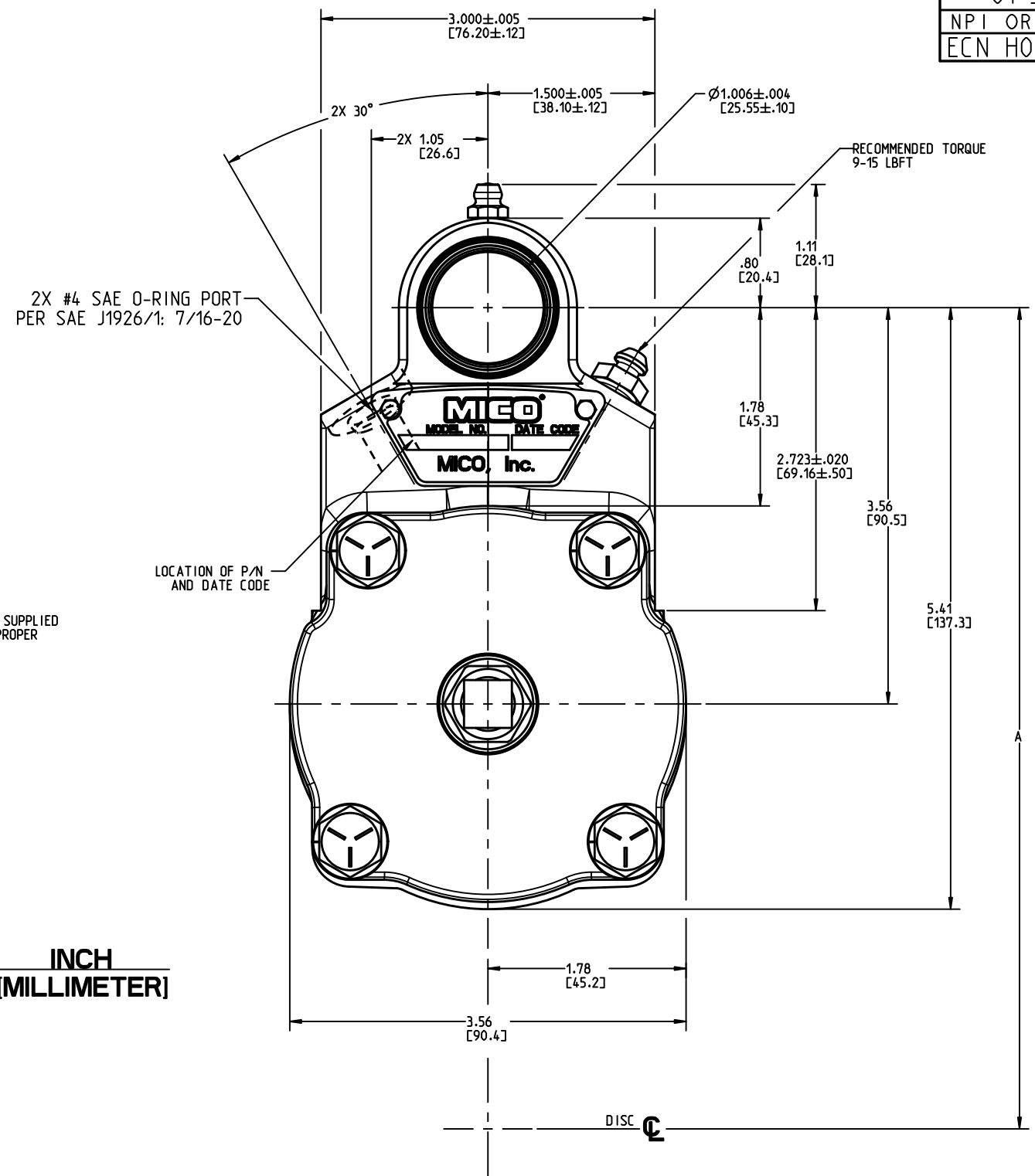

**NOTES:**

- 1) TO BE USED WITH MINERAL BASE HYDRAULIC OIL ONLY .
- 2) BRAKE SHOWN IN THE HYDRAULICALLY APPLIED POSITION.
- 3) DIMENSIONS MAY VARY BETWEEN UNITS AND ARE TO BE USED FOR REFERENCE PURPOSES ONLY. MILLIMETER VALUES MAY NOT BE AN EXACT CONVERSION OF INCH VALUES.
- 4) APPLY A POLYMER BASE MOLY GREASE THRU ZERK FITTING AFTER ASSEMBLY UNTIL GREASE IS OBSERVED EXITING SEALS.
- 5) BRAKE SHOWN IN APPLIED POSITION.
- 6) BRAKE SURFACE FINISH: ZINC CHROMATE YELLOW PER ASTM B633, TYPE II, SC2
- 7) LINING MATERIAL: NON-ASBESTOS, LEAD FREE
- 8) SEAL KIT P/N 02-500-058.
- 9) REPAIR KIT P/N 02-500-223.
- 10) LINING KIT P/N 20-060-113.
- 11) UNIT COMES WITH SAE 37° (JIC) #4 STRAIGHT O-RING ADAPTOR.

**PERFORMANCE CHARACTERISTICS:**

- 1) BRAKE TORQUE: Bt (LBIN) = 1920 X (DISC RADIUS - 1.18)
- 2) MAXIMUM TORQUE ACHIEVED ONLY AFTER BRAKE HAS BEEN PROPERLY ADJUSTED AND BURNISHED.
- 3) COMPLETE RETRACTION PRESSURE: 1,000 PSI.
- 4) MAXIMUM CONTINUOUS DUTY PRESSURE IS 2000 PSI.
- 5) MAXIMUM INTERMITTENT DUTY PRESSURE IS 2500 PSI.
- 6) VOLUME REQUIRED FOR COMPLETE RETRACTION: .80 CU IN. MAXIMUM.
- 7) CAUTION: DISC RUBBING SPEED SHOULD NOT EXCEED 5,000 FT./MIN.
- 8) "A" DIMENSION = DISC RADIUS + 2.38 INCHES (DISC DIA. FROM 9 TO 15 INCHES).  
"A" DIMENSION = DISC RADIUS + 2.50 INCHES (DISC DIA. GREATER THAN 15 INCHES).

COMPONENT AND SYSTEM RECOMMENDATIONS MADE BY MICO, INC ARE BASED ON INFORMATION SUPPLIED BY POTENTIAL USER AND/OR SYSTEM DESIGNER. THE POTENTIAL USER AND/OR DESIGNER MUST MAKE FINAL ACCEPTANCE AND APPROVAL OF COMPONENTS AND SYSTEM AFTER TESTING PERFORMANCE ON AN ACTUAL APPLICATION FOR WHICH SYSTEM WAS DESIGNED.

MICO, INC CLAIMS PROPRIETARY RIGHTS TO THE MATERIAL DISCLOSED IN THIS DOCUMENT. THIS DOCUMENT IS PROVIDED IN CONFIDENCE AND MAY NOT BE REPRODUCED OR DISCLOSED WITHOUT WRITTEN PERMISSION FROM MICO, INC. COPYRIGHT MICO, INC. ALL RIGHTS RESERVED.

**MICO**<sup>®</sup>  
North Mankato, Minnesota USA

SCALE 0.750		TITLE SPRING BRAKE		
DWN JJC 2015-07-08	APVD PROD ENGRG	SIZE B	DRAWING NUMBER 01-530-306	REV F
X NO	APVD ENGRG BSW 2015-07-10		CUSTOMER COPY	1 2