

HYDRAULIC BRAKE VALVES

Pressure modulating brake valves,
relay valves, and steering assist valves



Versatile, High-performance
Hydraulic Brake Valves



ZF Off-Highway Solutions Minnesota Inc. designs, manufactures, and markets hydraulic components, controls, and brake systems, primarily for off-highway markets.

Many of the world's largest Off-Highway OEMs value the knowledgeable staff at ZF Off-Highway Solutions Minnesota Inc. and work with us to make their products better. Our custom-engineered products are designed with the customer requirements as the primary driver. It is our intent to help customers build their systems with our expertise in hydraulic components, braking systems, and controls. Our goal is to meet or exceed our customers' expectations in every aspect of our business.

ZF Off-Highway Solutions Minnesota Inc. continuously strives for improvement, while remaining a quality leader in our field. We are a successful, customer driven business. We look forward to working with you!

Edition 1

Version 1 (06.2023)

84-466-001 (en)

This publication is not subject to any update service. Information contained in this publication was in effect at the time the publication was approved for printing and is subject to change without notice or liability. ZF Off-Highway Solutions Minnesota Inc. reserves the right to revise the information presented or to discontinue the production of parts described at any time.

You will find the current edition at www.mico.com

Hydraulic Brake Valves

The same dependability, safety and performance that goes into every ZF Braking System Product also goes into our versatile, high-performance Brake Valves and Brake Valve Components. This is an important consideration when you select a source of supply for your fluid power needs.

The brake valves presented in this catalog are designed for vehicles that are equipped with other hydraulic power devices in either open center, closed center, or load sensing hydraulic systems. This design feature eliminates the need for a separate power brake unit or separate hydraulic fluid system.

Unless specified, all valves in this catalog are used with mineral base hydraulic oil. Consult ZF Off-Highway Solutions Minnesota Inc. when using other fluids. Dimensional drawings shown may vary slightly between similar units and are to be used for reference purposes only.

Complete the appropriate Application Data Sheet online, www.mico.com, and submit to sh-applications.NMN@ZF.com. The ZF Off-Highway Solutions Minnesota Inc. Applications Department will analyze your specifications and based on your input recommend a hydraulic brake valve suitable for your requirements.

Catalog Index

Pressure Modulating Valve Catalog Code.....	5
Single Modulating Valves (spool design).....	6
Roller Actuated	7
Push Rod Actuated	8
Lever Actuated.....	9
Pedal Actuated (floor mounted - vertical).....	10
Pedal Actuated with switch (floor mounted - vertical)	11
Pedal Actuated (floor mounted - horizontal)	12
Pedal Actuated (suspended - horizontal).....	13
Pedal Actuated (suspended - vertical).....	14
Tandem Modulating Valves (spool design).....	16
Roller Actuated (mechanically retained piston).....	17
Roller Actuated	18
Push Rod Actuated	19
Lever Actuated.....	20
Pedal Actuated (floor mounted - vertical).....	21
Pedal Actuated (floor mounted - horizontal)	22
Pedal Actuated (suspended - horizontal).....	23
Pedal Actuated with switch (suspended - horizontal)	24
Pedal Actuated (suspended - vertical).....	25
Tandem Modulating Valves with on/off pilot apply (spool design)	26
Roller Actuated	27
Pedal Actuated (floor mounted - vertical).....	28
Pedal Actuated (floor mounted - horizontal)	29
Pedal Actuated (suspended - vertical).....	30
Pedal Actuated with switch (suspended - vertical).....	31
Tandem Modulating Valves with modulated proportional pilot apply (spool design).....	32
Roller Actuated	33
Pedal Actuated (floor mounted - vertical).....	34
Pedal Actuated (floor mounted - horizontal)	35
Single Modulating Valves (poppet design)	36
Push Rod Actuated	37
Pedal Actuated (floor mounted - vertical).....	38
Pedal Actuated with two valves (floor mounted - vertical)	39
Two Single Valves with pilot apply (poppet design).....	40
Pedal Actuated (floor mounted - vertical).....	41
Reverse Modulating Valves (spool design)	42
Pull Actuated.....	43
Pedal Actuated (floor mounted - vertical).....	44
Pedal Actuated (suspended - horizontal).....	45
Reverse Modulating Valves (poppet design).....	46
Pull Actuated.....	47
Pedal Actuated (wide floor mounted - vertical)	48
Pedal Actuated (narrow floor mounted - vertical).....	49
Relay Valves.....	50-51
Hystat Brake Valves	52-53
Park Brake Valves with Auto Apply.....	54-55
Dual Power Brake Valve for Steering Assist.....	56-57
Linked Pedal Controls (shown with tandem modulating valve)	58-59
Useful Formulas	60

Applications



Forestry Equipment



Agricultural Equipment



Heavy Construction
Equipment



Swing Drive Equipment



Mining Equipment



In-Plant & Warehouse
Equipment



Airport Support
Vehicles

Pressure Modulating Valve Catalog Code

FOR MODELS WITH PEDAL



Product designator

PMV = Pressure modulating valve with a pedal and base
 PMO = Pressure modulating valve only

Maximum Valve Pressure Setting

NNNN = Brake pressure setting (bar)
 (example: 0810 = 81.0 bar)

Valve Configuration

S = Single
 T = Tandem

Brake Pressure Curve

L = Linear
 S = Staged
 Explained in chart below.

Pilot Port Configuration

NO = No pilot port
 MS = Modulating version #4 SAE J1926/1: ORB port
 MM = Modulating version per SAE J2244/1: M12 x 1.5, metric port
 SS = Sealed piston on/off version #4 SAE J1926/1: ORB port
 SM = Sealed piston on/off version per SAE J2244/1: M12 x 1.5, metric

* Port Configuration and Orientation

PS06 = #6 SAE J1926/1: ORB ports standard orientation
 PR06 = #6 SAE J1926/1: ORB ports reverse orientation
 PS08 = #8 SAE J1926/1: ORB ports standard orientation
 PR08 = #8 SAE J1926/1: ORB ports reverse orientation
 SM10 = #10 SAE J2244/1: ports standard orientation (metric)
 RM10 = #10 SAE J2244/1: ports reverse orientation (metric)
 SM12 = #12 SAE J2244/1: ports standard orientation (metric)
 RM12 = #12 SAE J2244/1: ports reverse orientation (metric)
 N006 = #6 SAE J1926/1: ORB ports - valve only
 N008 = #8 SAE J1926/1: ORB ports - valve only

* Dimensional illustrations in this catalog are shown in the standard orientation.

NOTE: Not all listed code combinations are attainable.

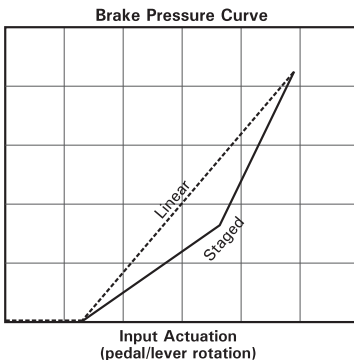

Explanation:

Linear brake pressure curve is a straight line from the end of dead band (start of pressure rise) to the ultimate pressure setting.

Staged brake pressure rise has a flatter slope for the first part of the curve and then transitions to a steeper slope to achieve the ultimate pressure setting. Staged brake pressure rise can be favorable in applications where less aggressive braking is desired in early input actuation.

Pedal Pivot Pin

SB = Standard base and pin (no bushings in base)
 SS = Stainless steel pin and bushings in base

* Base Type

NNN = None
Floor Mounted Pedal
 FHN = Horizontal valve
 FHS = Horizontal valve with sensor
 FHW = Horizontal valve with switch
 FVN = Vertical valve
 FVS = Vertical valve with sensor
 FVW = Vertical valve with switch
Suspended Pedal
 WHN = Horizontal valve
 WHS = Horizontal valve with sensor
 WHW = Horizontal valve with switch
 WVN = Vertical valve
 WVS = Vertical valve with sensor
 WVW = Vertical valve with switch

* Refer to drawings throughout catalog

For more information about sensor or switch base types consult a ZF Off-Highway Solutions Minnesota Inc. Applications Specialist.

Desired Pedal Force Range

L = 155.7 N to 209.1 N (35 lb to 47 lb)
 M = 213.5 N to 266.9 N (48 lb to 60 lb)
 H = 266.9 N and above (60 lb and above)

Pedal Angle

XX = Pedal angle
 Treadle from 25° to 50° in 5° increments
 NN = 63° suspended pedal (approximately)

Actuation Type

R = Piston for roller actuation
 P = Piston for push rod actuation (base type must be "NNN")
 T = Treadle
 S = Suspended

For more information about lever types consult a ZF Off-Highway Solutions Minnesota Inc. Applications Specialist.

(spool design)

Single Modulating Valves

DESCRIPTION

These single modulating valves are a closed center spool design. They provide a modulated output pressure of up to 206.8 bar (3000 PSI) and a maximum input pressure of 206.8 bar (3000 PSI). Standard brake pressure settings are in increments of 3.5 bar (50 PSI).

When used with a properly sized accumulator and a ZF Off-Highway Accumulator Charging Valve, these valves provide normal and emergency power-off braking in a variety of open-center, closed-center, and load sensing hydraulic systems. For detailed information about principles of operation contact ZF Off-Highway Solutions Minnesota Inc.

Available as valve only, push rod actuated, lever actuated, and pedal actuated. These valves can also be designed with options such as built-in switches, potentiometers, etc.

FEATURES

- Compact size for use in restricted space
- Oil immersed spring cavity protects return springs from outside contaminants
- Spool design provides smooth modulation at all pressures
- Provides "pedal feel" proportional to brake system pressure

Typical Circuit Schematic

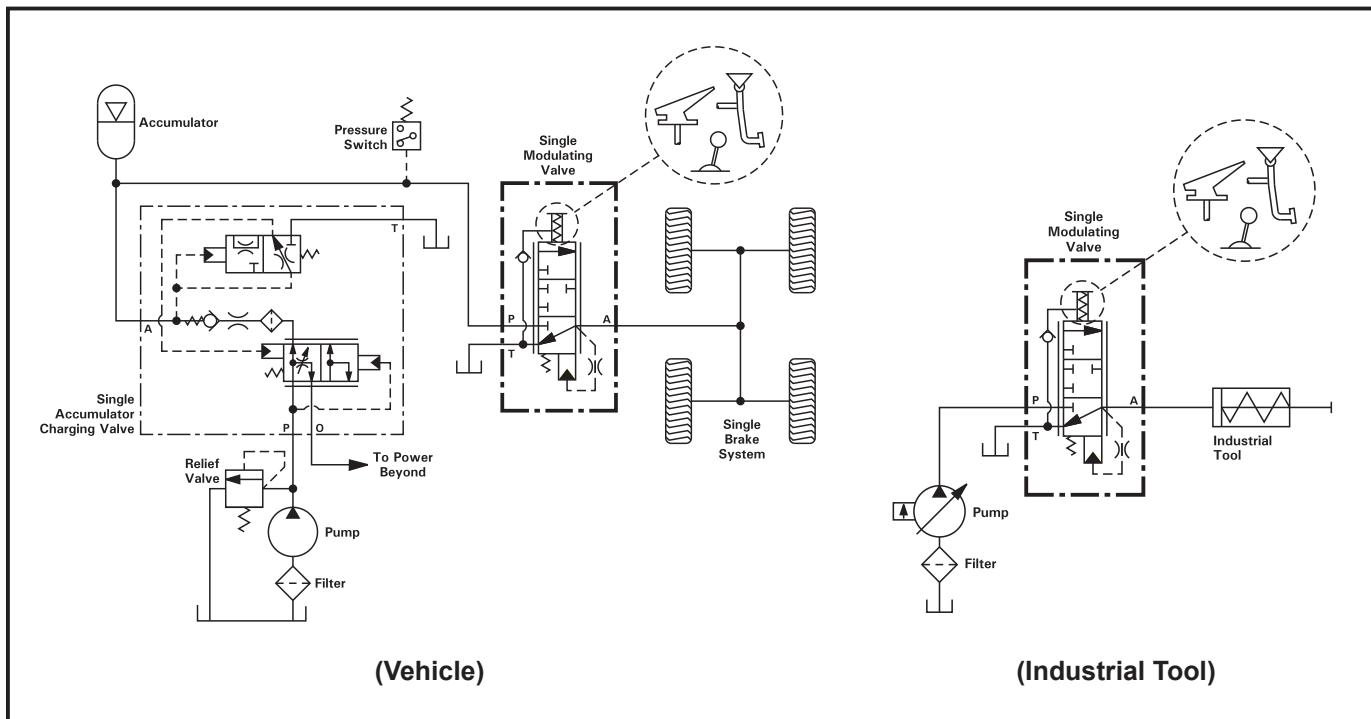

Roller Actuated (single)



Typical Brake Valve

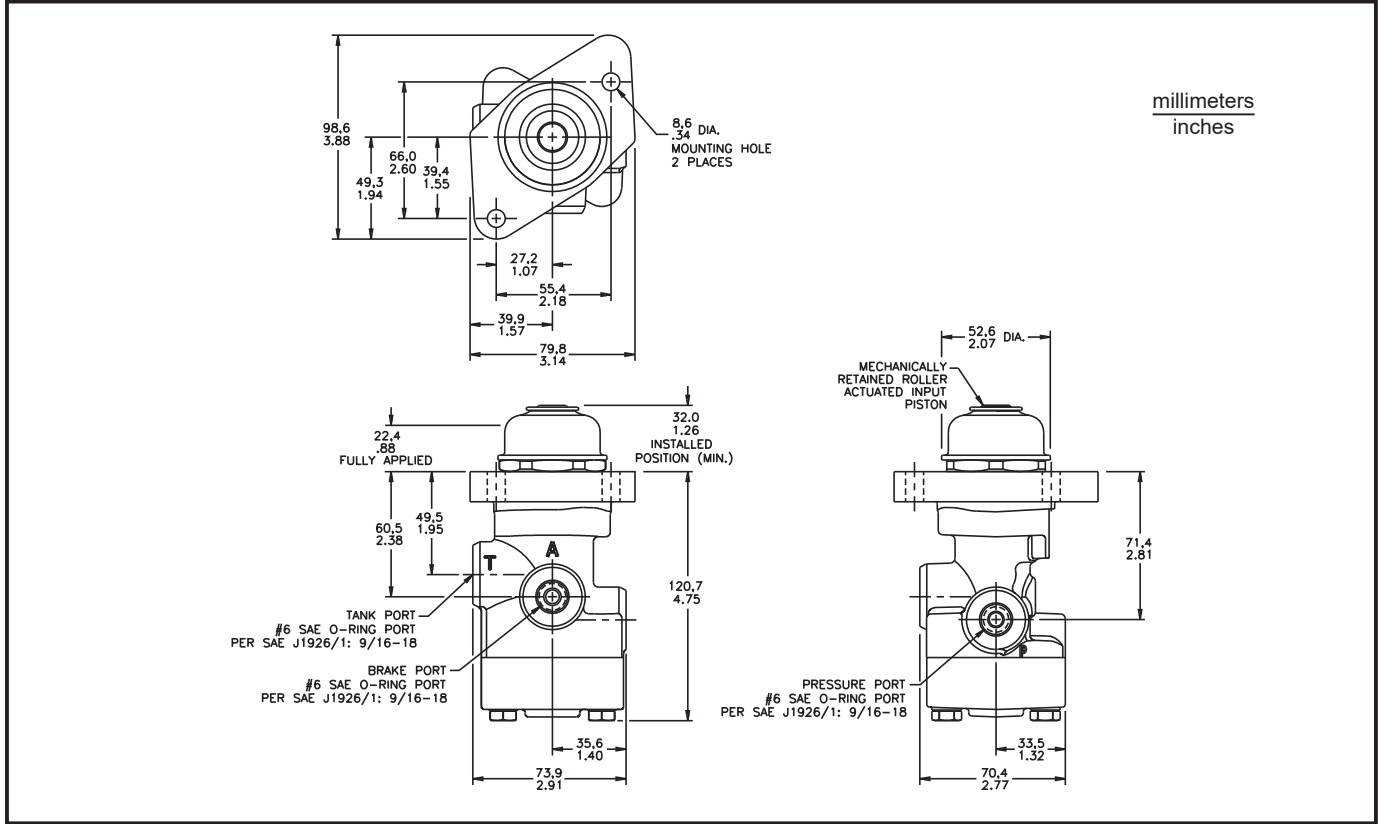

SPECIFICATIONS

Model Number	Catalog Code (refer to page 5)	Nominal Brake Pressure Setting Tolerance		Approximate Input Force at Pressure Setting	
		bar	(PSI)	N	(lb)
20-100-831	PMO-0276SSNO-N006R	± 1.7	(± 25)	1032.0	(232)

Brake pressure setting range all models 20.7 bar (300 PSI) to 206.8 bar (3000 PSI) in standard 3.5 bar (50 PSI) increments

Maximum input pressure all models 206.8 bar (3000 PSI)

Consult ZF Off-Highway Solutions Minnesota Inc. Applications Department for other available models and application detail.

Push Rod Actuated (single)



Typical Brake Valve

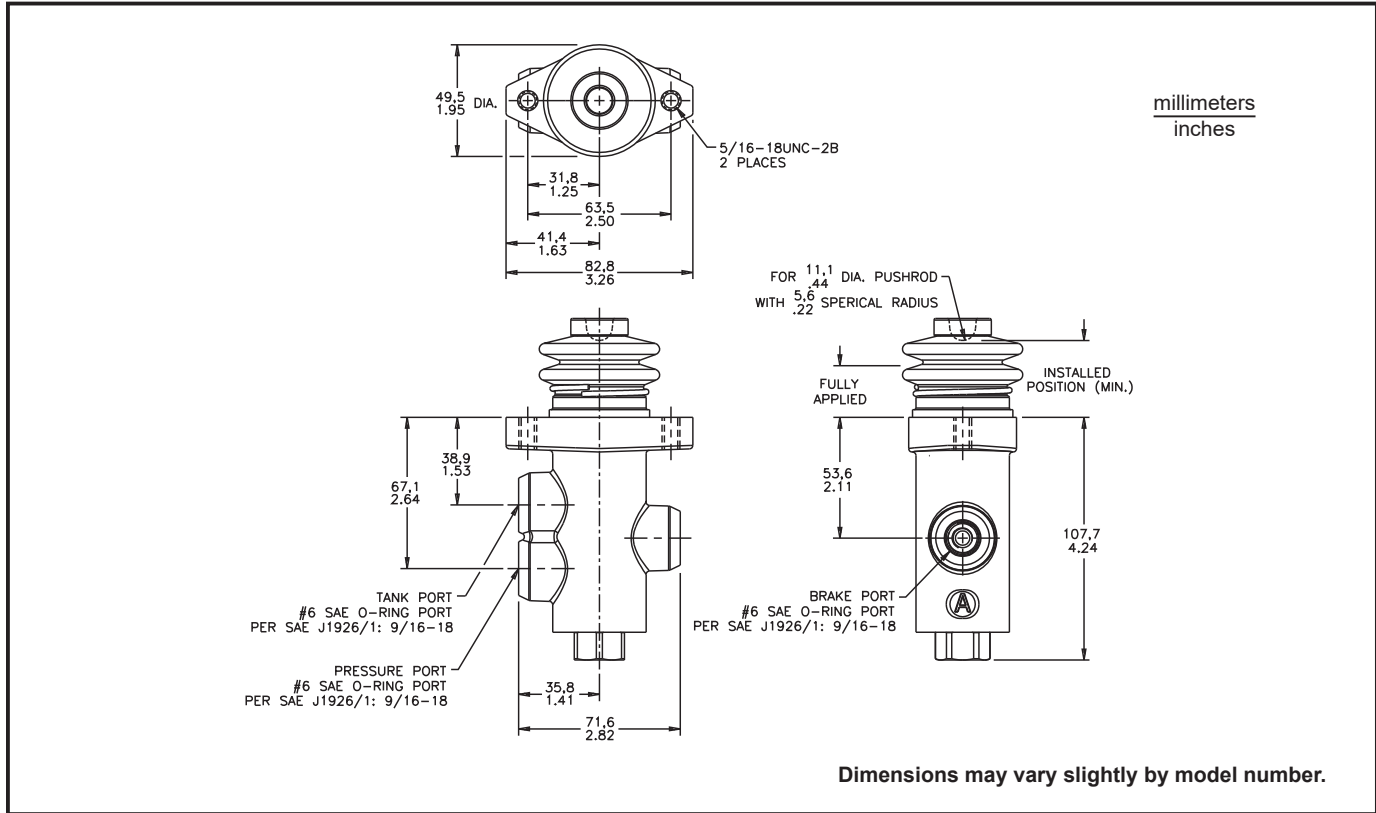

SPECIFICATIONS

Model Number	Catalog Code (refer to page 5)	Nominal Brake Pressure Setting Tolerance		Approximate Push Rod Force at Pressure Setting		Approximate Push Rod Stroke	
		bar	(PSI)	N	(lb)	mm	(inch)
03-466-104	PMO-0810SLNO-N006-P	± 1.7	(± 25)	751.8	(169)	11.2	(0.44)
03-466-116	PMO-0259-SSNO-N006-P	± 1.7	(± 25)	791.8	(178)	9.1	(0.36)

(no corresponding catalog code for this model number)

Model Number	Brake Pressure Setting		Approximate Push Rod Force at Pressure Setting		Approximate Push Rod Stroke	
	bar	(PSI)	N	(lb)	mm	(inch)
*03-466-106	120.7 ± 3.5	(1750 ± 50)	1089.8	(245)	11.2	(0.44)

* Tank port is #8 SAE o-ring port.

Brake pressure setting range all models 20.7 bar (300 PSI) to 206.8 bar (3000 PSI) in standard 3.5 bar (50 PSI) increments

Maximum input pressure all models 206.8 bar (3000 PSI)

Consult ZF Off-Highway Solutions Minnesota Inc. Applications Department for other available models and application detail.

Lever Actuated



Typical Brake Valve

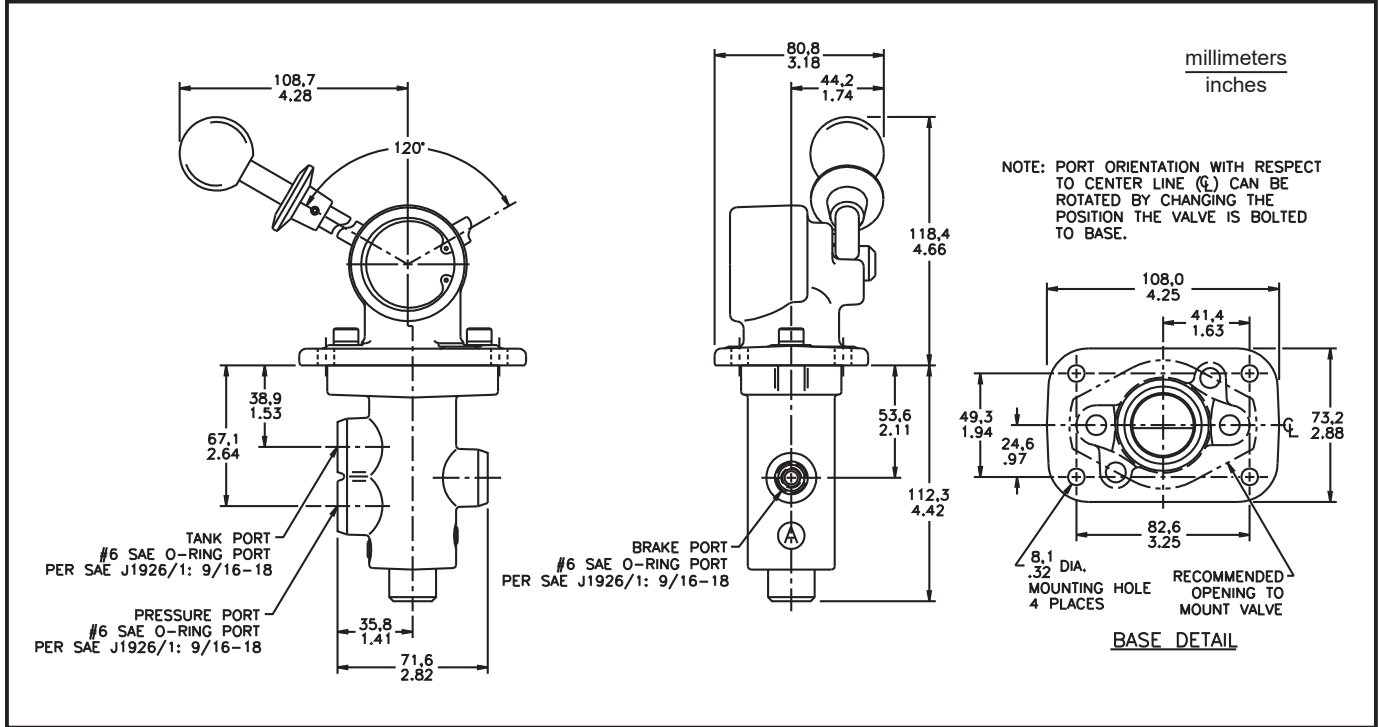

SPECIFICATIONS (no corresponding catalog code for these model numbers)

Model Number	Brake Pressure Setting	
	bar	(PSI)
06-466-456	48.3 ± 3.5	(700 ± 50)
06-466-902	100.0 ± 3.5	(1450 ± 50)
06-466-903	72.4 ± 3.5	(1050 ± 50)
06-466-910	113.8 ± 5.2	(1650 ± 75)
06-466-912	27.6 ± 1.7	(400 ± 25)
06-466-913	139.0 ± 3.5	(2000 ± 50)

The lever rotates 120° from full-off to full-on position and held in the full-on position by a finger release mechanism.

Brake pressure setting range all models 20.7 bar (300 PSI) to 206.8 bar (3000 PSI) in standard 3.5 bar (50 PSI) increments

Maximum input pressure all models 206.8 bar (3000 PSI)

Consult ZF Off-Highway Solutions Minnesota Inc. Applications Department for other available models and application detail.

Pedal Actuated (single)



Typical Brake Valve

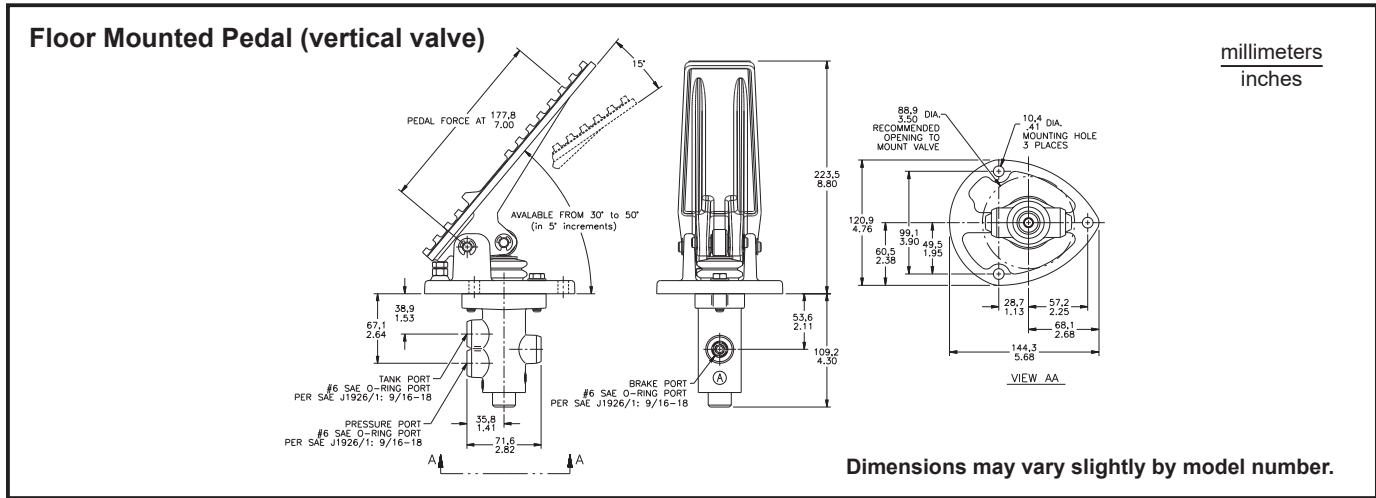

SPECIFICATIONS

Model Number	Catalog Code (refer to page 5)	Nominal Brake Pressure Setting Tolerance		Approximate Pedal Force at Pressure Setting	
		bar	(PSI)	N	(lb)
06-466-103	PMV-1034SLNO-PS06-T35M-FVNSS	± 3.5	(± 50)	253.6	(57)
06-466-110	PMV-0379SLNO-PS06-T50L-FVNSB	± 3.5	(± 50)	182.4	(41)
06-466-112	PMV-0655SLNO-PS06-T50H-FVNSB	± 1.7	(± 25)	298.0	(67)
06-466-113	PMV-0379SLNO-PS06-T35L-FVNSS	± 3.5	(± 50)	177.9	(40)
06-466-114	PMV-0552SLNO-PS06-T50L-FVNSB	± 3.5	(± 50)	182.4	(41)
06-466-115	PMV-0655SLNO-PS06-T35L-FVNSS	± 3.5	(± 50)	209.1	(47)
06-466-118	PMV-0552SLNO-PS06-T35M-FVNSB	± 3.5	(± 50)	253.6	(57)
06-466-121	PMV-0827SLNO-PS06-T35M-FVNSB	± 3.5	(± 50)	244.7	(55)
06-466-122	PMV-1034SLNO-PS06-T25L-FVNSB	± 3.5	(± 50)	182.4	(41)
06-466-124	PMV-0276SLNO-PS06-T50L-FVNSB	± 1.7	(± 25)	191.3	(43)
06-466-126	PMV-0758SLNO-PS06-T35M-FVNSB	± 3.5	(± 50)	226.9	(51)
06-466-130	PMV-1034SLNO-PS06-T35H-FVNSB	± 3.5	(± 50)	298.0	(67)
06-466-132	PMV-0931SLNO-PS06-T35H-FVNSB	± 3.5	(± 50)	271.3	(61)
06-466-137	PMV-0414SLNO-PS06-T50H-FVNSS	± 3.5	(± 50)	289.1	(65)
06-466-139	PMV-0827SLNO-PS06-T35M-FVNSS	± 3.5	(± 50)	249.1	(56)
06-466-140	PMV-0552SSNO-PS06-T55M-FVNSB	± 3.5	(± 50)	253.6	(57)
06-466-142	PMV-0276SSNO-PS06-T50L-FVNSB	± 1.7	(± 25)	195.7	(44)
06-466-146	PMV-0621SLNO-PS06-T35H-FVNSB	± 3.5	(± 50)	284.7	(64)
06-466-147	PMV-0414SLNO-PS06-T30H-FVNSS	± 3.5	(± 50)	289.1	(65)
06-466-158	PMV-0448SSNO-PS06-T50M-FVNSB	± 3.5	(± 50)	213.5	(48)
06-466-160	PMV-0276SSNO-PS06-T35L-FVNSB	± 1.7	(± 25)	195.7	(44)
06-466-162	PMV-1241SLNO-PS06-T50M-FVNSS	± 3.5	(± 50)	222.4	(50)
06-466-169	PMV-0007SLNO-PS06-T45L-FVNSS	± 0.3	(± 5)	93.4	(21)
06-466-170	PMV-0552SLNO-PS06-T45L-FVNSS	± 3.5	(± 50)	177.9	(40)
06-466-172	PMV-1034SSNO-PS06-T55H-FVNSB	± 3.5	(± 50)	311.4	(70)
06-466-173	PMV-0011SLNO-PS06-T45L-FVNSB	± 1.4	(± 20)	102.3	(23)
06-466-181	PMV-1379SLNO-PS06-T35M-FVNSS	± 3.5	(± 50)	244.7	(55)
06-466-187	PMV-0276SLNO-PS06-T30L-FVNSS	± 1.7	(± 25)	209.1	(47)
06-466-198	PMV-0448SLNO-PS06-T40H-FVNSB	± 5.2	(± 75)	306.9	(69)
06-466-302	PMV-0379SSNO-PS06-T50L-FVNSB	± 2.1	(± 30)	200.2	(45)
06-466-309	PMV-1172SSNO-PS06-T50M-FVNSS	± 3.5	(± 50)	213.5	(48)
06-466-431	PMV-0228SLNO-PS08-T50L-FVNSS	± 1.4	(± 20)	177.9	(40)
06-466-497	PMV-1034SLNO-PS06-T30L-FVNSB	± 3.5	(± 50)	191.3	(43)

Brake pressure setting range all models 20.7 bar (300 PSI) to 206.8 bar (3000 PSI) in standard 3.5 bar (50 PSI) increments

Maximum input pressure all models 206.8 bar (3000 PSI)

Consult ZF Off-Highway Solutions Minnesota Inc. Applications Department for other available models and application detail.

Pedal Actuated (single with switch)

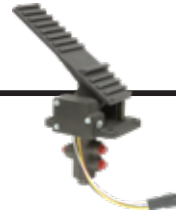

Typical Brake Valve

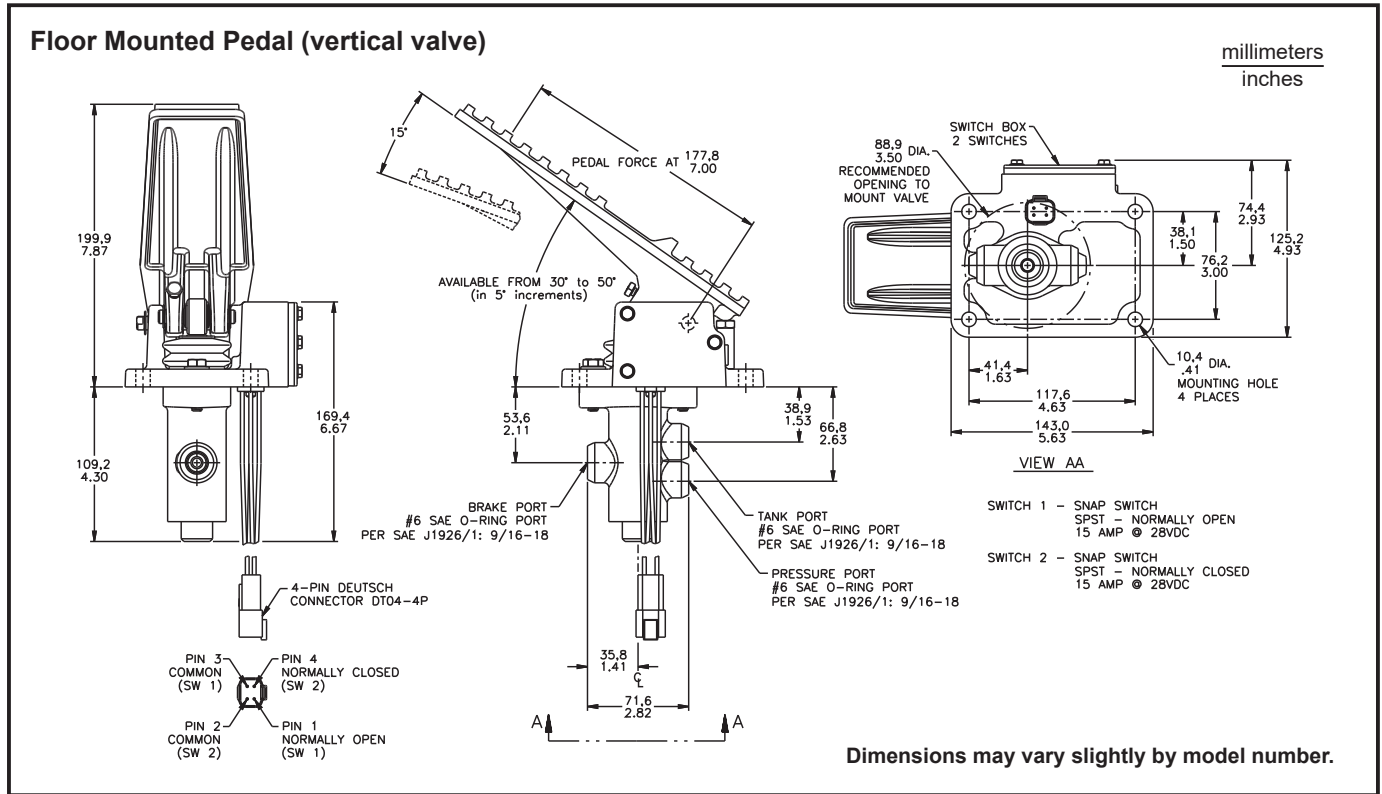

SPECIFICATIONS

Model Number	Catalog Code (refer to page 5)	Nominal Brake Pressure Setting Tolerance		Approximate Pedal Force at Pressure Setting	
		bar	(PSI)	N	(lb)
06-466-989	PMV-0690SLNP-PS06-T35L-FVWSS	± 3.5	(± 50)	209.1	(47)

Brake pressure setting range all models 20.7 bar (300 PSI) to 206.8 bar (3000 PSI) in standard 3.5 bar (50 PSI) increments
 Maximum input pressure all models 206.8 bar (3000 PSI)

Consult ZF Off-Highway Solutions Minnesota Inc. Applications Department for other available models and application detail.

Pedal Actuated (single)



Typical Brake Valve

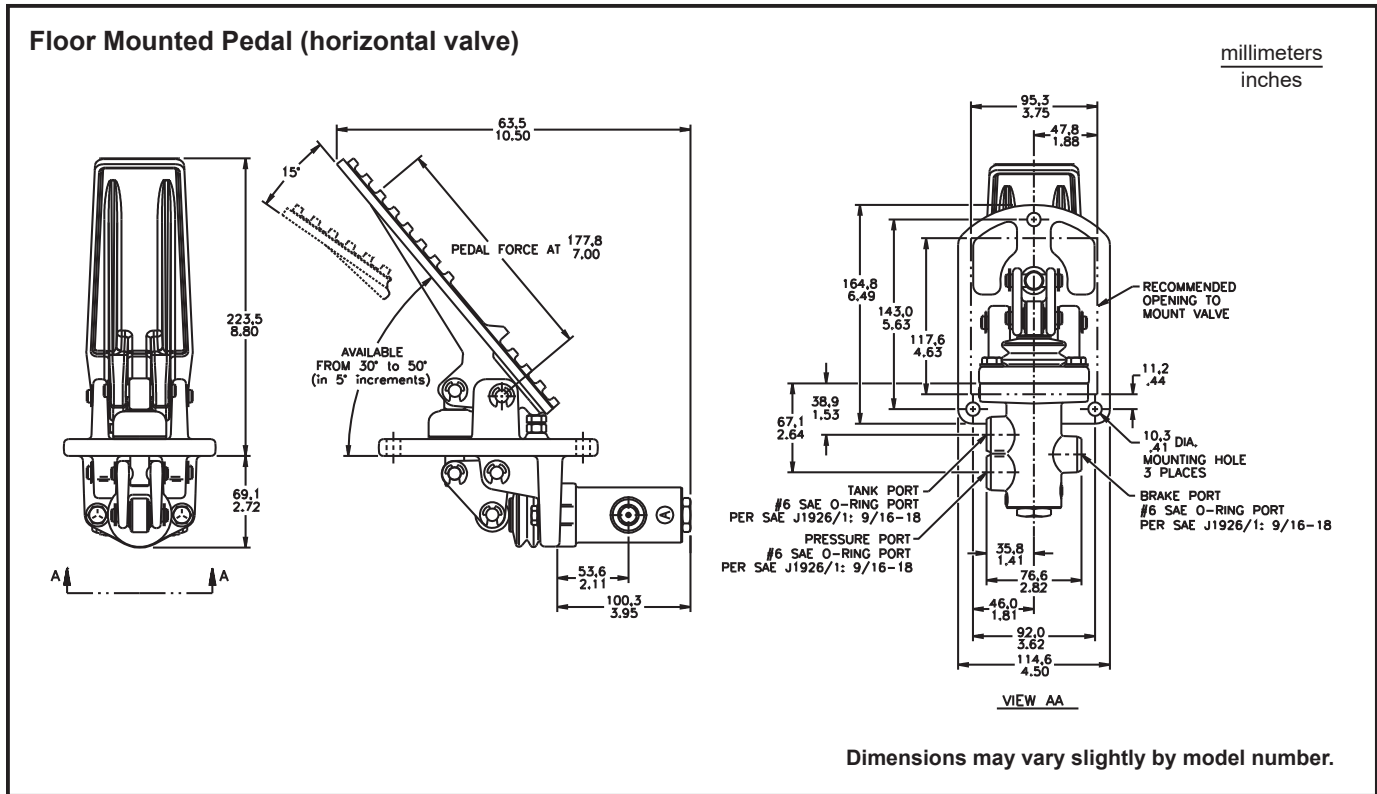

SPECIFICATIONS

Model Number	Catalog Code (refer to page 5)	Nominal Brake Pressure Setting Tolerance		Approximate Pedal Force at Pressure Setting	
		bar	(PSI)	N	(lb)
06-466-184	PMV-0379SLNO- PS06-T50L-FHNSB	± 3.5	(± 50)	182.4	(41)
06-466-186	PMV-0690SLNO-PR06-T50H-FHNSB	± 3.5	(± 50)	320.3	(72)

Brake pressure setting range all models 20.7 bar (300 PSI) to 206.8 bar (3000 PSI) in standard 3.5 bar (50 PSI) increments
 Maximum input pressure all models 206.8 bar (3000 PSI)
 Consult ZF Off-Highway Solutions Minnesota Inc. Applications Department for other available models and application detail.

Pedal Actuated (single)



Typical Brake Valve

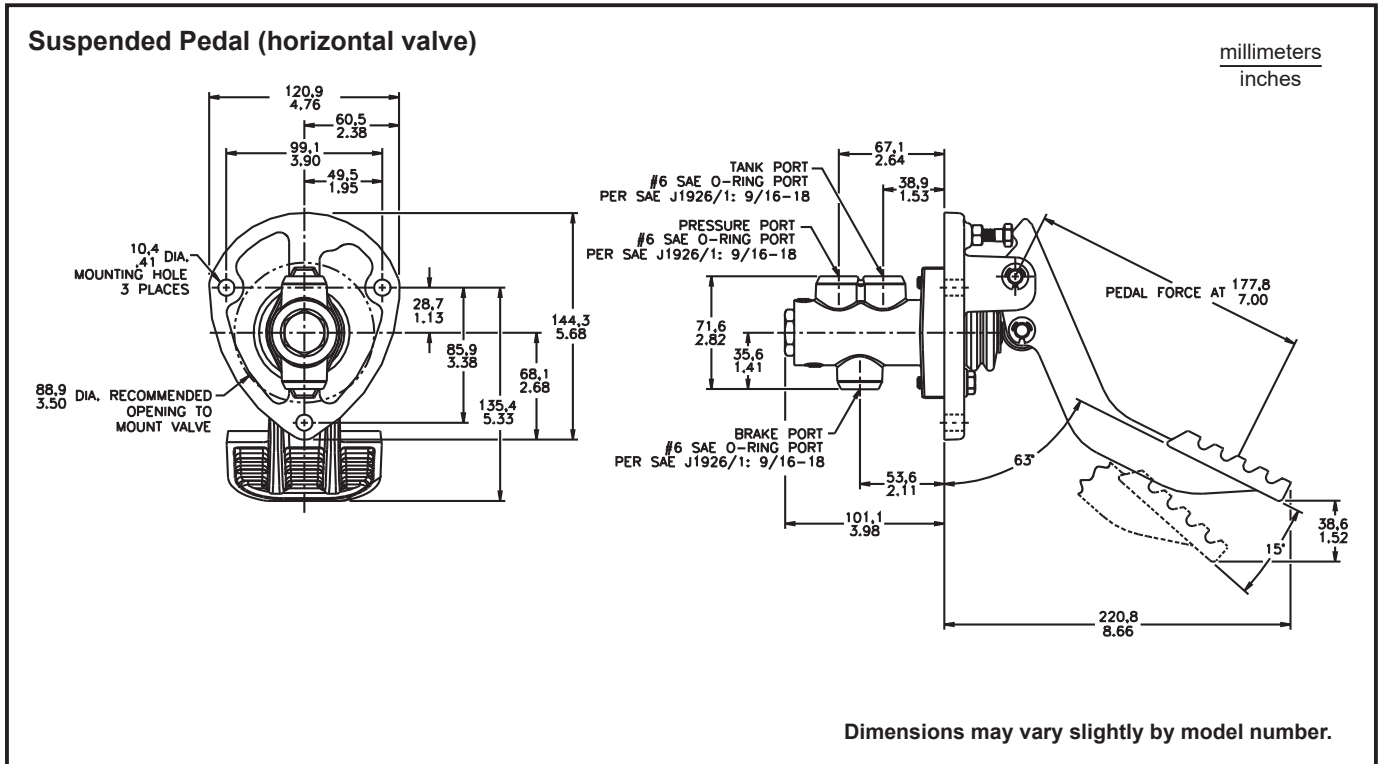

SPECIFICATIONS

Model Number	Catalog Code (refer to page 5)	Nominal Brake Pressure Setting Tolerance		Approximate Pedal Force at Pressure Setting	
		bar	(PSI)	N	(lb)
06-466-105	PMV-0483SSNO-PS06-SNNL-WHNSS	± 3.5	(± 50)	186.8	(42)
06-466-189	PMV-1379SSNO-PS06-SNNM-WHNSS	± 6.9	(± 100)	253.5	(57)
06-466-192	PMV-1034SLNO-PS06-SNNH-WHNSS	± 3.5	(± 50)	298.0	(67)
06-466-194	PMV-0827SLNO-PS06-SNNM-WHNSS	± 3.5	(± 50)	245.0	(55)

Brake pressure setting range all models 20.7 bar (300 PSI) to 206.8 bar (3000 PSI) in standard 3.5 bar (50 PSI) increments
 Maximum input pressure all models 206.8 bar (3000 PSI)
 Consult ZF Off-Highway Solutions Minnesota Inc. Applications Department for other available models and application detail.

Pedal Actuated (single)



Typical Brake Valve

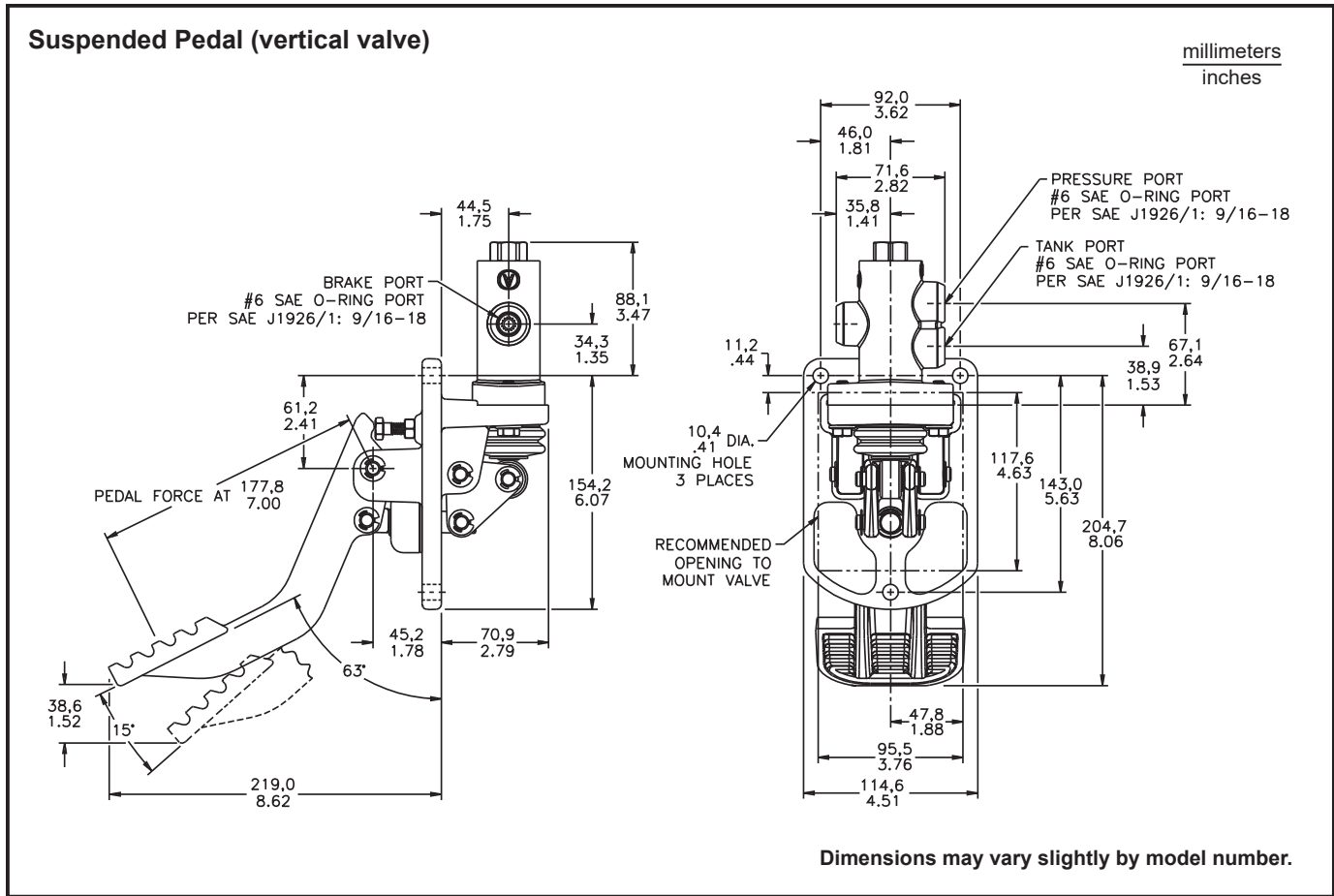

SPECIFICATIONS

Model Number	Catalog Code (refer to page 5)	Nominal Brake Pressure Setting Tolerance		Approximate Pedal Force at Pressure Setting	
		bar	(PSI)	N	(lb)
06-466-117	PMV-0448SLNO-PS06-SNNM-WVNSS	± 1.7	(± 25)	226.9	(51)
06-466-171	PMV-0552SSNO-PS06-SNNH-WVNSS	± 3.5	(± 50)	284.7	(64)

Brake pressure setting range all models 20.7 bar (300 PSI) to 206.8 bar (3000 PSI) in standard 3.5 bar (50 PSI) increments
 Maximum input pressure all models 206.8 bar (3000 PSI)
Consult ZF Off-Highway Solutions Minnesota Inc. Applications Department for other available models and application detail.



BRAKES



**HYDRAULIC OVER AIR
RELAY VALVES**



**ELECTROHYDRAULIC
VALVES**



**ACCUMULATOR
CHARGING VALVES**



**MODULATING BRAKE
VALVES**



QUADRIGAGE™



FLUID RESERVOIRS



ELECTRONIC PEDALS



REMOTE ACTUATORS



Learn more about our hydraulic products at:
www.mico.com

(spool design)

Tandem Modulating Valves

DESCRIPTION

These Tandem Modulating Valves are a closed center spool design, providing isolated pressure outputs for front and rear brakes. In the event of failure in either half of the brake system, the other portion of the brake valve will continue to function. They provide a modulated output pressure of up to 206.8 bar (3000 PSI) and a maximum input pressure of 206.8 bar (3000 PSI). Standard brake pressure settings are in increments of 3.5 bar (50 PSI).

When used with properly sized accumulators and a ZF Off-Highway Accumulator Charging Valve, these valves provide normal and emergency power-off braking in a variety of open-center, closed-center, and load sensing hydraulic systems. For detailed information about principles of operation contact ZF Off-Highway Solutions Minnesota Inc.

Models are available as valve only, push rod actuated, lever actuated, and pedal actuated. These valves can also be designed with options such as built-in switches, potentiometers, etc.

FEATURES

- Compact size for use in restricted space
- Provides independent braking to front and rear brake systems from one valve
- Oil immersed spring cavity protects return springs from outside contaminants
- Spool design provides smooth modulation at all pressures
- Provides "pedal feel" proportional to brake system pressure
- Tank ports communicated internally allow for one or two return lines to tank

Typical Circuit Schematic

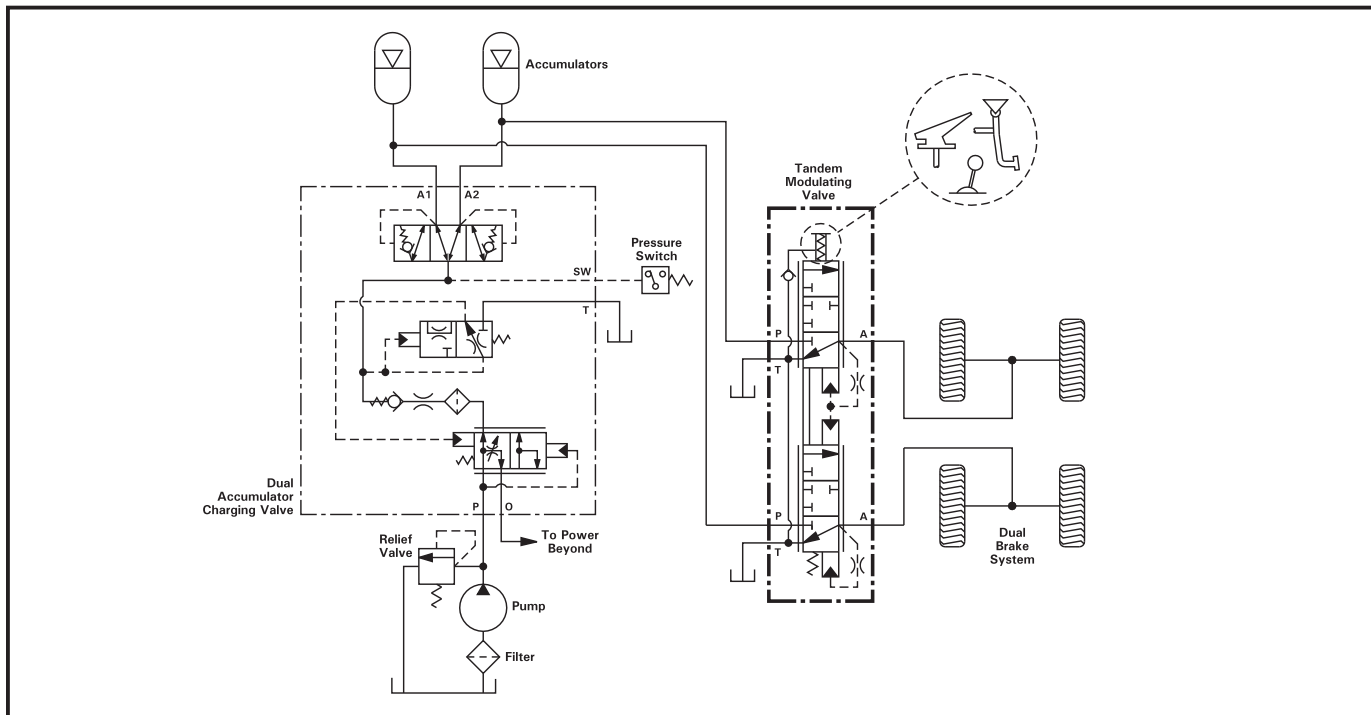

Roller Actuated (tandem)



Typical Brake Valve

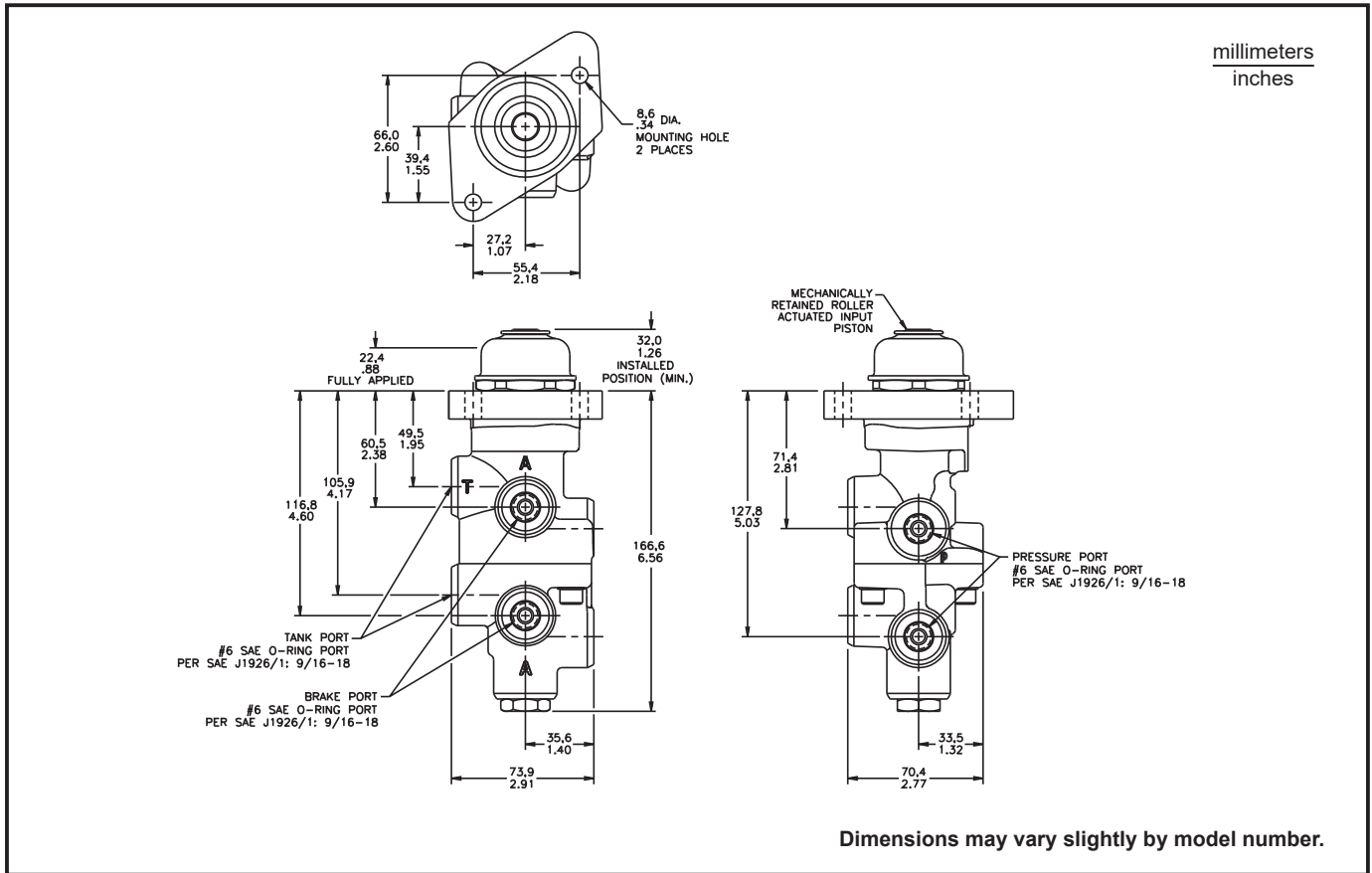

SPECIFICATIONS

Model Number	Catalog Code (refer to page 5)	Nominal Brake Pressure Setting Tolerance		Approximate Input Force at Pressure Setting	
		bar	(PSI)	N	(lb)
20-100-754	PMO-0345TSNO-N006-R	± 1.7	(± 25)	1236.6	(278)
20-100-867	PMO-0758TSNO-N006-R	± 3.5	(± 50)	1160.9	(261)
20-100-916	PMO-0620TSNO-N006-R	± 3.5	(± 50)	1023.1	(230)

Brake pressure setting range all models 20.7 bar (300 PSI) to 206.8 bar (3000 PSI) in standard 3.5 bar (50 PSI) increments

Maximum input pressure all models 206.8 bar (3000 PSI)

Consult ZF Off-Highway Solutions Minnesota Inc. Applications Department for other available models and application detail.

Roller Actuated (tandem)



Typical Brake Valve

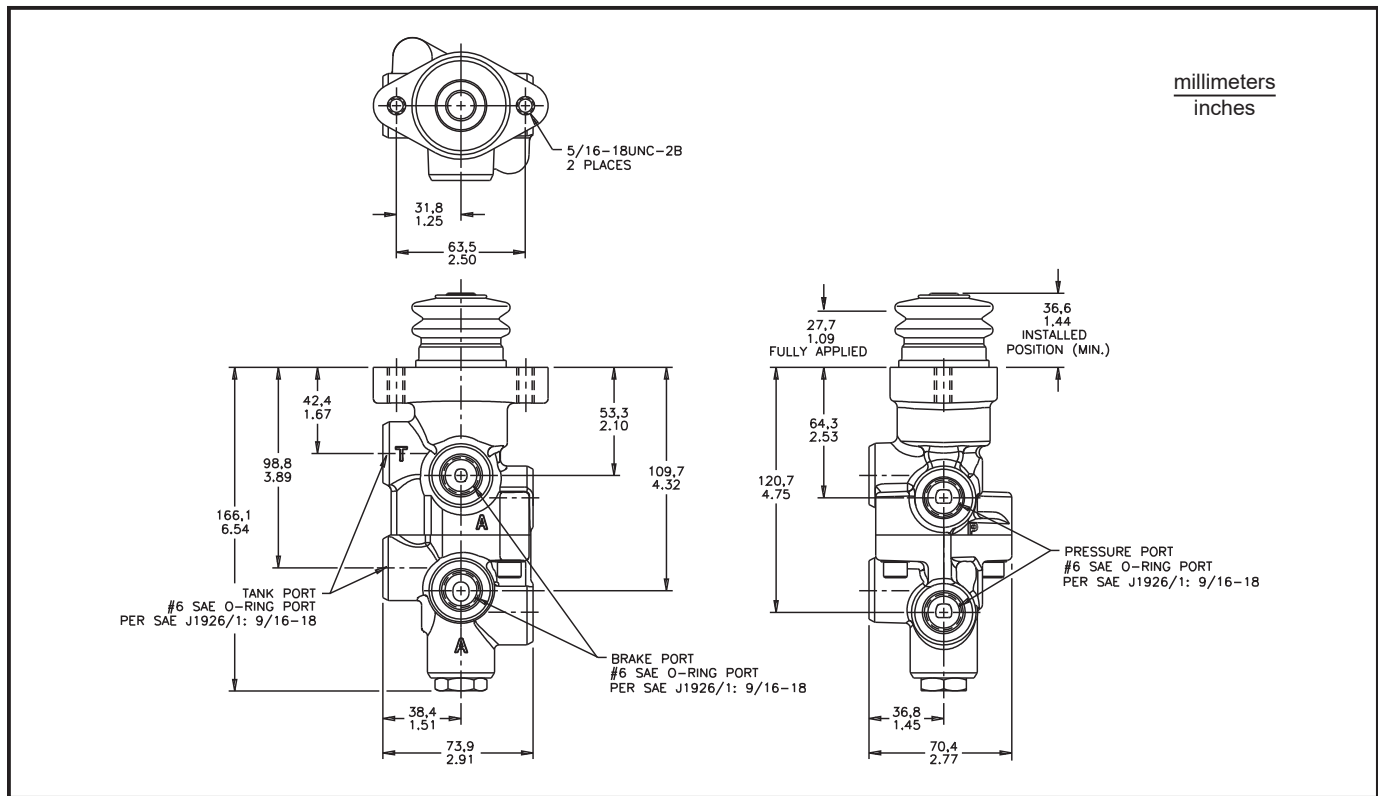

SPECIFICATIONS

Model Number	Catalog Code (refer to page 5)	Nominal Brake Pressure Setting Tolerance		Approximate Input Force at Pressure Setting	
		bar	(PSI)	N	(lb)
20-100-916	PMO-0621TSNO-N006-R	± 3.5	(± 50)	1005.3	(226)
20-100-930	PMO-0655TLNO-N008-R	± 3.5	(± 50)	1481.3	(333)

Brake pressure setting range all models 20.7 bar (300 PSI) to 206.8 bar (3000 PSI) in standard 3.5 bar (50 PSI) increments
 Maximum input pressure all models 206.8 bar (3000 PSI)
Consult ZF Off-Highway Solutions Minnesota Inc. Applications Department for other available models and application detail.

Push Rod Actuated (tandem)



Typical Brake Valve

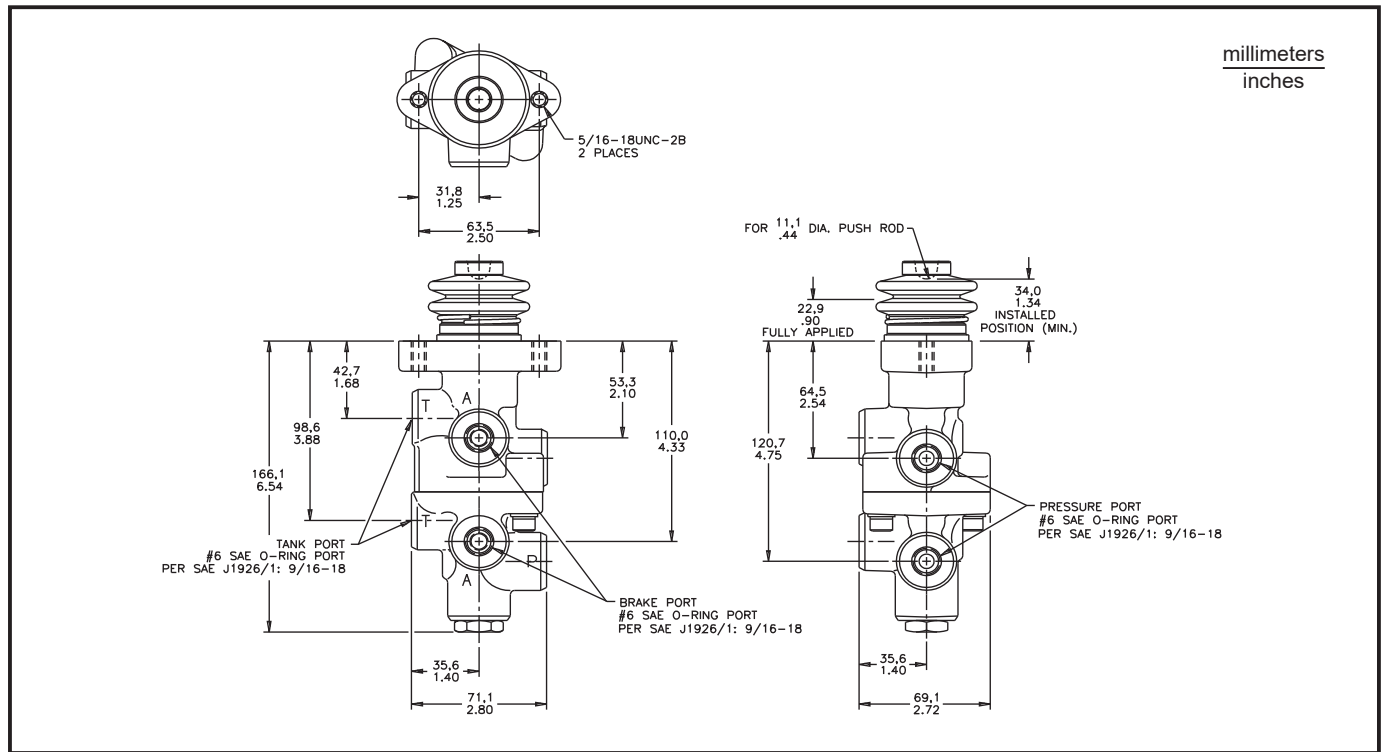

SPECIFICATIONS

Model Number	Catalog Code (refer to page 5)	Nominal Brake Pressure Setting Tolerance		Approximate Input Force at Pressure Setting	
		bar	(PSI)	N	(lb)
20-100-952	PMO-0827TSNO-N006-P	± 5.2	(± 75)	1236.6	(278)

Brake pressure setting range all models 20.7 bar (300 PSI) to 206.8 bar (3000 PSI) in standard 3.5 bar (50 PSI) increments
 Maximum input pressure all models 206.8 bar (3000 PSI)

Consult ZF Off-Highway Solutions Minnesota Inc. Applications Department for other available models and application detail.

Lever Actuated (tandem)



Typical Brake Valve

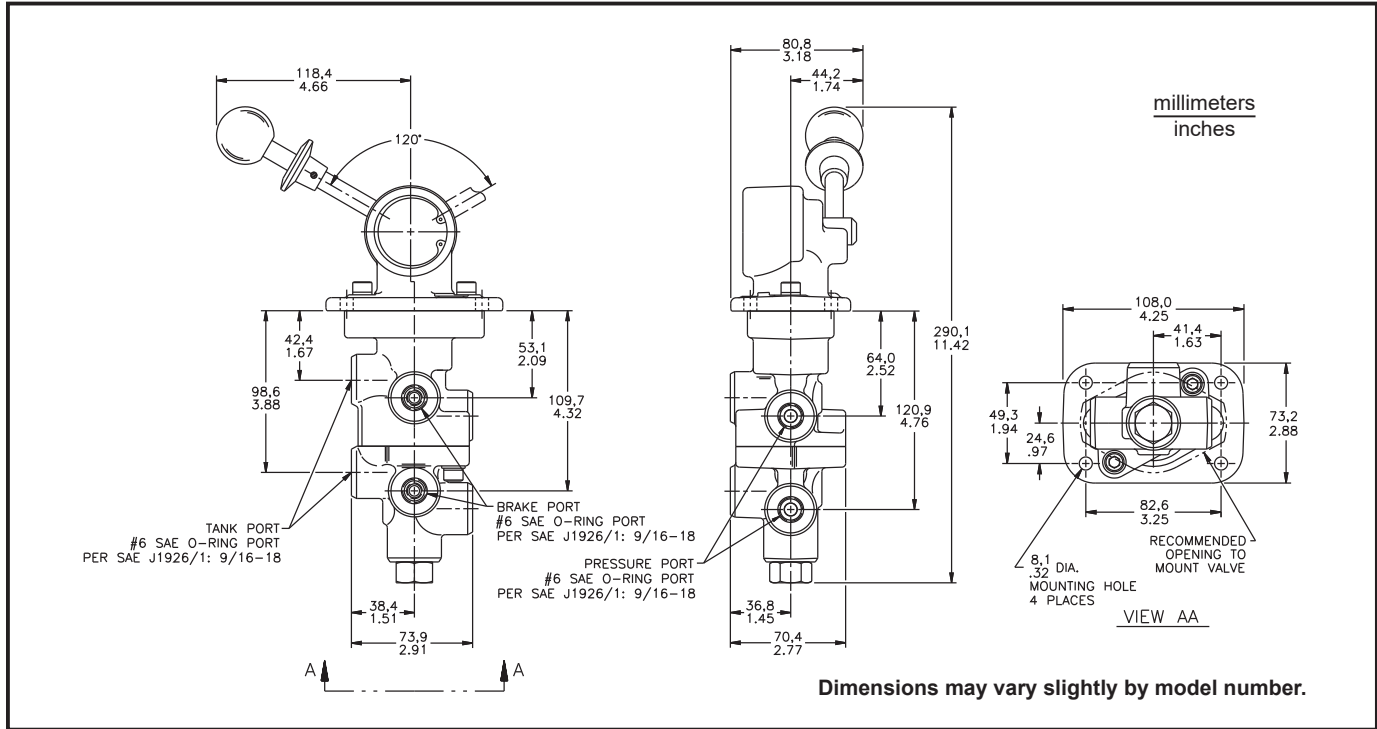

SPECIFICATIONS (no corresponding catalog code for these model numbers)

Model Number	Brake Pressure Setting	
	bar	(PSI)
06-466-916	120.7 ± 6.9	(1750 ± 100)
06-466-939	37.9 ± 3.5	(550 ± 50)

The lever rotates 120° from full-off to full-on position and held in the full-on position by a finger release mechanism.
 Brake pressure setting range all models 20.7 bar (300 PSI) to 206.8 bar (3000 PSI) in standard 3.5 bar (50 PSI) increments
 Maximum input pressure all models 206.8 bar (3000 PSI)
Consult ZF Off-Highway Solutions Minnesota Inc. Applications Department for other available models and application detail.

Pedal Actuated (tandem)



Typical Brake Valve

Floor Mounted Pedal (vertical valve)

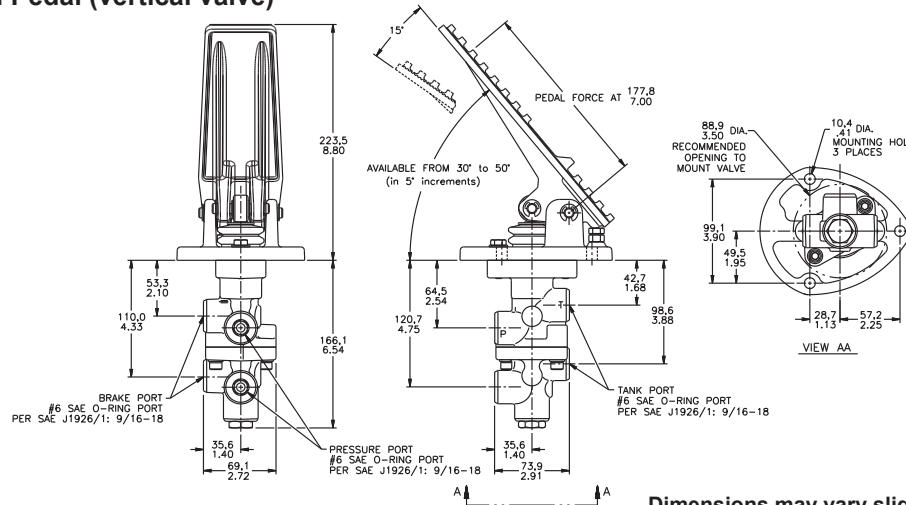

SPECIFICATIONS

Model Number	Catalog Code (refer to page 5)	Nominal Brake Pressure Setting Tolerance		Approximate Pedal Force at Pressure Setting	
		bar	(PSI)	N	(lb)
06-466-200	PMV-0827TLNO-PS06-T50M-FVNSB	± 5.2	(± 75)	244.7	(55)
06-466-202	PMV-1517TLNO-PS06-T50M-FVNSB	± 6.9	(± 100)	253.5	(57)
06-466-206	PMV-1034TLNO-PS06-T50M-FVNSB	± 5.2	(± 75)	244.7	(55)
06-466-208	PMV-1379TLNO-PS06-T50M-FVNSB	± 6.9	(± 100)	231.3	(52)
06-466-210	PMV-0690TLNO-PS06-T50H-FVNSB	± 5.2	(± 75)	306.9	(69)
06-466-214	PMV-0896TLNO-PS06-T35M-FVNSB	± 5.2	(± 75)	262.4	(59)
06-466-216	PMV-0414TLNO-PS06-T50L-FVNSB	± 5.2	(± 75)	204.6	(46)
06-466-218	PMV-0690TLNO-PS06-T35H-FVNSB	± 5.2	(± 75)	306.9	(69)
06-466-220	PMV-1034TLNO-PS06-T35H-FVNSB	± 5.2	(± 75)	298.0	(67)
06-466-222	PMV-1034TLNO-PS06-T25L-FVNSB	± 5.2	(± 75)	182.4	(41)
06-466-230	PMV-0414TLNO-PS06-T40L-FVNSB	± 5.2	(± 75)	204.6	(46)
06-466-231	PMV-0345TSNO-PS06-T50L-FVNSS	± 3.5	(± 50)	173.5	(39)
06-466-232	PMV-0448TLNO-PS06-T50M-FVNSB	± 3.5	(± 50)	218.0	(49)
06-466-234	PMV-0276TSNO-PS08-T50L-FVNSB	± 3.5	(± 50)	200.2	(45)
06-466-236	PMV-1241TLNO-PS06-T50M-FVNSB	± 6.9	(± 100)	213.5	(48)
06-466-238	PMV-0552TLNO-PS06-T35H-FVNSB	± 5.2	(± 75)	306.9	(69)
06-466-240	PMV-0534TLNO-PS06-T50M-FVNSB	± 3.5	(± 50)	253.5	(57)
06-466-241	PMV-0448TSNO-PS06-T50M-FVNSS	± 3.5	(± 50)	213.5	(48)
06-466-244	PMV-0483TLNO-PS06-T35M-FVNSB	± 3.5	(± 50)	231.3	(52)
06-466-245	PMV-0483TSNO-PS06-T50M-FVNSS	± 3.5	(± 50)	231.3	(52)
06-466-248	PMV-0448TLNO-PR06-T25L-FVNSB	± 2.4	(± 35)	204.6	(46)
06-466-250	PMV-1241TLNO-PS06-T25M-FVNSB	± 6.9	(± 100)	213.5	(48)
06-466-252	PMV-0690TLNO-PS06-T50H-FVNSB	± 3.5	(± 50)	275.8	(62)
06-466-253	PMV-0344TSNO-PS06-T35L-FVNSS	± 3.5	(± 50)	177.9	(40)
06-466-258	PMV-1517TLNO-PS06-T50M-FVNSS	± 6.9	(± 100)	253.5	(57)
06-466-260	PMV-1034TLNO-PS06-T50H-FVNSS	± 5.2	(± 75)	298.0	(67)
06-466-262	PMV-1379TLNO-PS06-T50M-FVNSS	± 6.9	(± 100)	231.3	(52)
06-466-264	PMV-0690TLNO-PS06-T50H-FVNSS	± 5.2	(± 75)	306.9	(69)
06-466-266	PMV-0414TLNO-PS06-T50L-FVNSS	± 5.2	(± 75)	204.6	(46)
06-466-268	PMV-0690TLNO-PS06-T35H-FVNSS	± 5.2	(± 75)	306.9	(69)
06-466-270	PMV-0534TLNO-PS06-T50M-FVNSS	± 3.5	(± 50)	244.7	(55)
06-466-429	PMV-1379TLNO-PR06-T50M-FVNSS	± 6.9	(± 100)	235.8	(53)
06-466-601	PMV-1034TSNO-PS08-T35M-FVNSB	± 5.2	(± 75)	235.8	(53)

Brake pressure setting range
all models20.7 bar (300 PSI)
to 206.8 bar (3000 PSI)
in standard 3.5 bar
(50 PSI) increments

Maximum input pressure
all models206.8 bar (3000 PSI)

**Consult ZF Off-Highway Solutions
Minnesota Inc. Applications Department
for other available models and application
detail.**

Pedal Actuated (tandem)



Typical Brake Valve

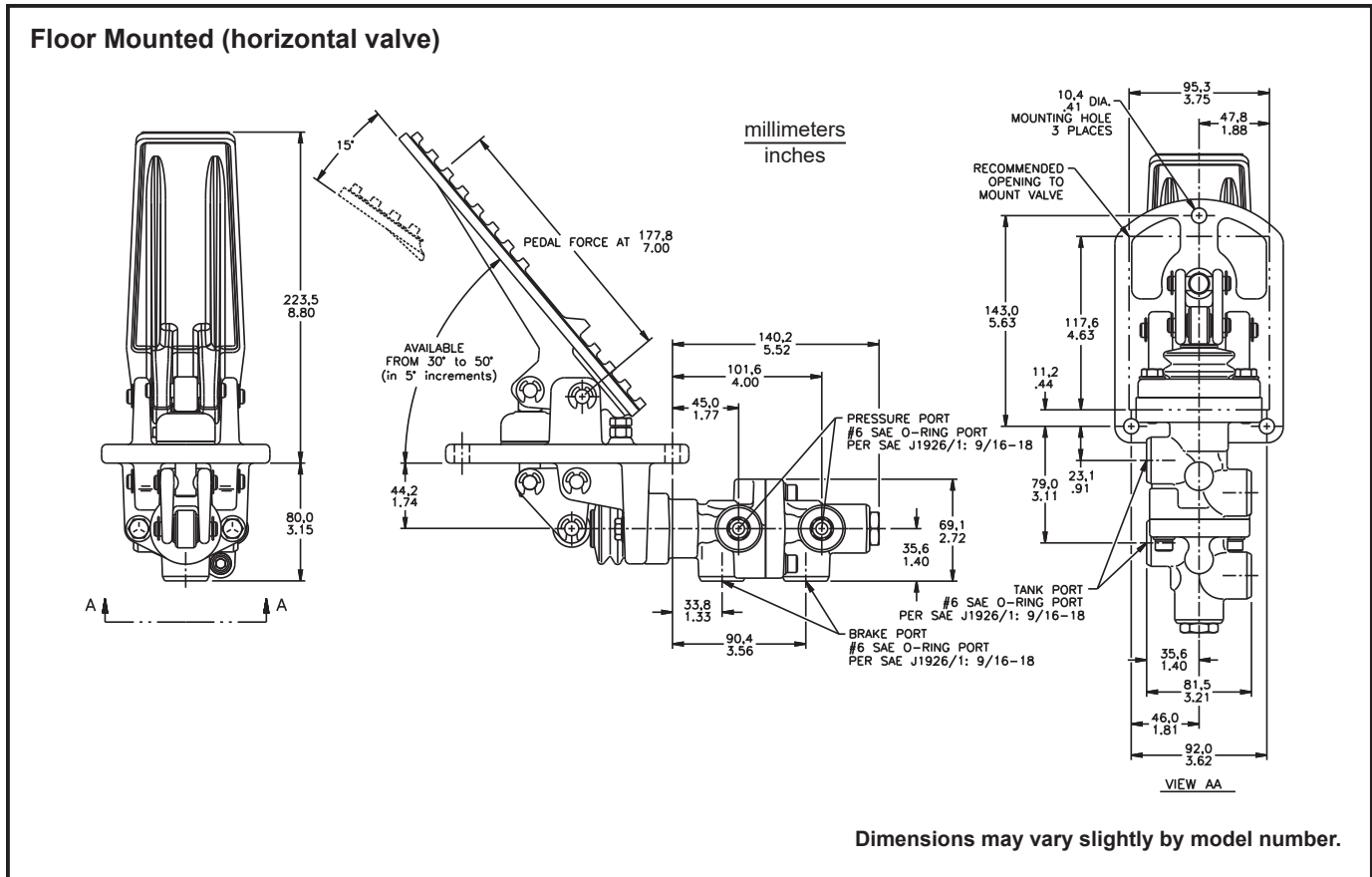

SPECIFICATIONS

Model Number	Catalog Code (refer to page 5)	Nominal Brake Pressure Setting Tolerance		Approximate Pedal Force at Pressure Setting	
		bar	(PSI)	N	(lb)
06-466-282	PMV-1034TLNO-PS06-T50H-FHNSB	± 5.2	(± 75)	298.0	(67)
06-466-284	PMV-1379TLNO-PS06-T50M-FHNSB	± 6.9	(± 100)	231.3	(52)
06-466-286	PMV-0517TLNO-PS06-T50M-FHNSB	± 5.2	(± 75)	249.1	(56)
06-466-288	PMV-1034TLNO-PS06-T35M-FHNSB	± 5.2	(± 75)	235.8	(53)
06-466-290	PMV-1379TLNO-PS06-T35M-FHNSB	± 6.9	(± 100)	235.8	(53)
06-466-292	PMV-0690TLNO-PS06-T50H-FHNSB	± 5.2	(± 75)	306.9	(69)
06-466-295	PMV-0345TSNO-PS06-T50L-FHNSB	± 3.5	(± 50)	177.9	(40)
06-466-296	PMV-1034TLNO-PS06-T50H-FHNSB	± 5.2	(± 75)	298.0	(67)
06-466-297	PMV-1586TLNO-PS06-T50M-FHNSB	± 6.9	(± 100)	235.8	(53)
06-466-298	PMV-1586TLNO-PS06-T35M-FHNSB	± 6.9	(± 100)	266.9	(60)

Brake pressure setting range all models 20.7 bar (300 PSI) to 206.8 bar (3000 PSI) in standard 3.5 bar (50 PSI) increments
 Maximum input pressure all models 206.8 bar (3000 PSI)
Consult ZF Off-Highway Solutions Minnesota Inc. Applications Department for other available models and application detail.

Pedal Actuated (tandem)



Typical Brake Valve

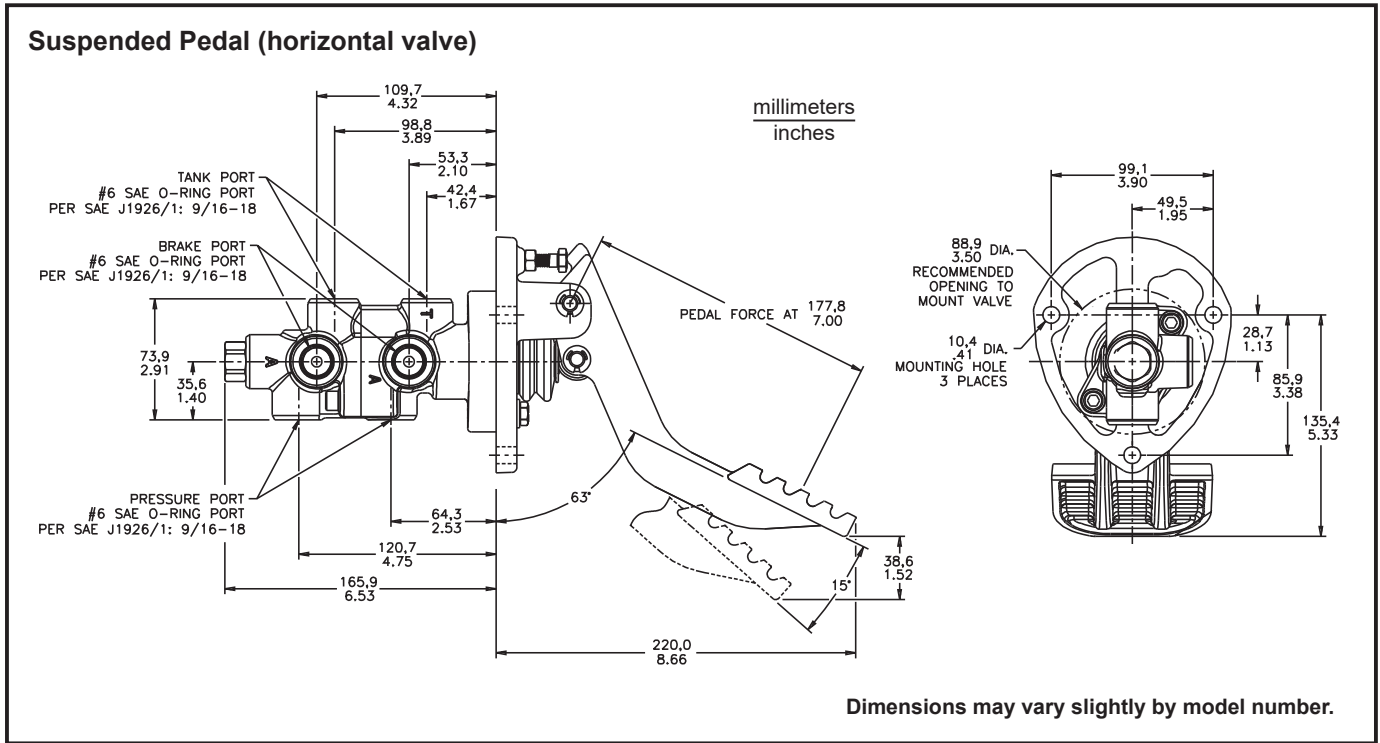

SPECIFICATIONS

Model Number	Catalog Code (refer to page 5)	Nominal Brake Pressure Setting Tolerance		Approximate Pedal Force at Pressure Setting	
		bar	(PSI)	N	(lb)
06-466-204	PMV-1120TSNO-PS06-SNNM-WHNSB	± 3.5	(± 50)	258.0	(58)
06-466-228	PMV-0534TLNO-PS06-SNNM-WHNSS	± 3.5	(± 50)	253.5	(57)
06-466-239	PMV-0896TLNO-PS06-SNNM-WHNSS	± 5.2	(± 75)	262.4	(59)

Brake pressure setting range all models 20.7 bar (300 PSI) to 206.8 bar (3000 PSI) in standard 3.5 bar (50 PSI) increments

Maximum input pressure all models 206.8 bar (3000 PSI)

Consult ZF Off-Highway Solutions Minnesota Inc. Applications Department for other available models and application detail.

Pedal Actuated (tandem with switch)



Typical Brake Valve

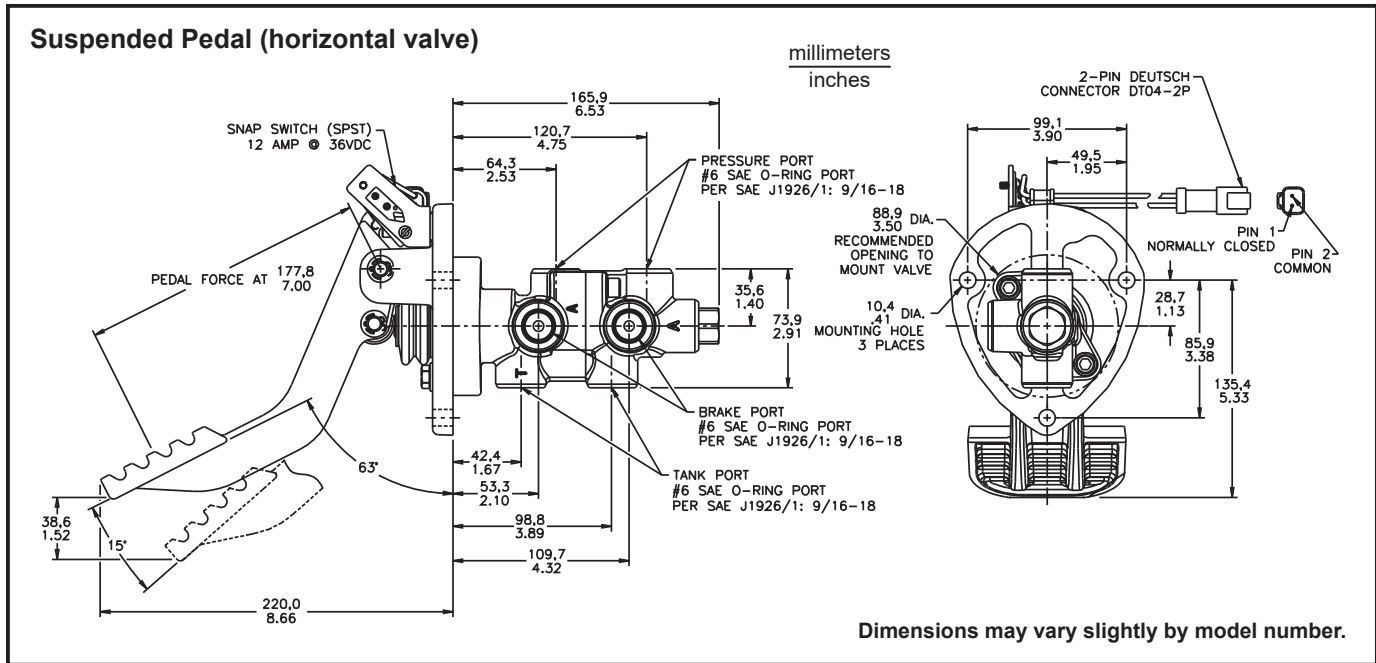

SPECIFICATIONS

Model Number	Catalog Code (refer to page 5)	Nominal Brake Pressure Setting Tolerance		Approximate Pedal Force at Pressure Setting	
		bar	(PSI)	N	(lb)
06-466-209	PMV-1034TLNO-PR06-SNNH-WHWSS	± 5.2	(± 75)	298.0	(67)
06-466-227	PMV-1586TLNO-PR06-SNNM-WHWSS	± 6.9	(± 100)	262.4	(59)
06-466-229	PMV-1207TLNO-PR06-SNNM-WHWSS	± 6.9	(± 100)	262.4	(59)

Brake pressure setting range all models 20.7 bar (300 PSI) to 206.8 bar (3000 PSI) in standard 3.5 bar (50 PSI) increments
 Maximum input pressure all models 206.8 bar (3000 PSI)

Consult ZF Off-Highway Solutions Minnesota Inc. Applications Department for other available models and application detail.

Pedal Actuated (tandem)



Typical Brake Valve

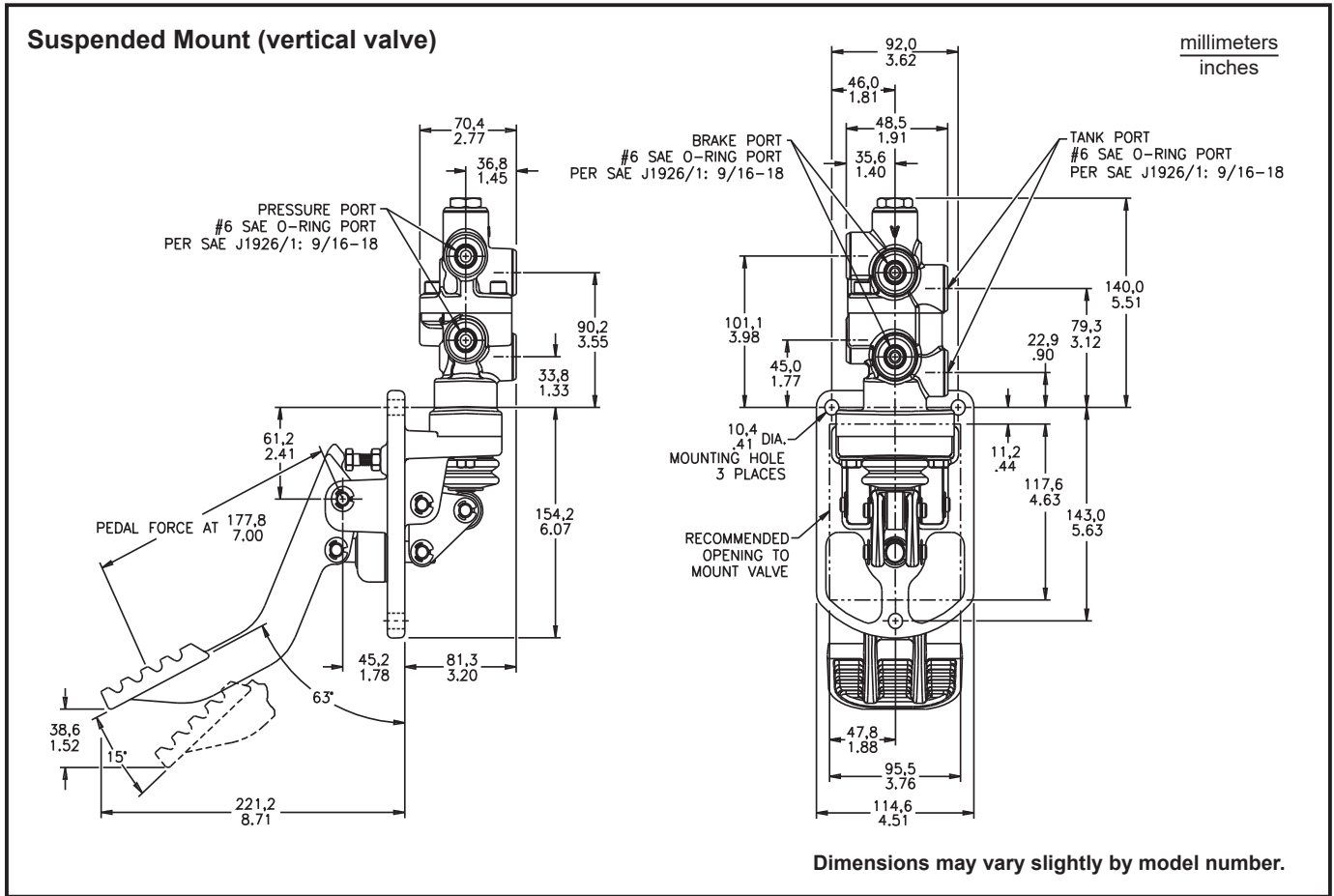

SPECIFICATIONS

Model Number	Catalog Code (refer to page 5)	Nominal Brake Pressure Setting Tolerance		Approximate Pedal Force at Pressure Setting	
		bar	(PSI)	N	(lb)
06-466-201	PMV-1379TLNO-PS06-SNNM-WVNSS	± 6.9	(± 100)	226.9	(51)
06-466-207	PMV-1034TLNO-PS06-SNNH-WVNSS	± 5.2	(± 75)	298.0	(67)
06-466-233	PMV-0690TSNO-PS06-SNNM-WVNSS	± 3.5	(± 50)	213.5	(48)
06-466-235	PMV-1207TLNO-PS06-SNNH-WVNSS	± 6.9	(± 100)	262.4	(59)
06-466-299	PMV-0517TLNO-PS06-SNNM-WVNSS	± 5.2	(± 75)	258.0	(58)
06-466-301	PMV-0448TSNO-PS06-SNNM-WVNSS	± 3.5	(± 50)	213.5	(48)
06-466-430	PMV-0690TSNO-PS06-SNNH-WVNSS	± 5.2	(± 75)	298.0	(67)
06-466-488	PMV-0827TSNO-PS06-SNNM-WVNSS	± 5.2	(± 75)	249.1	(56)

Brake pressure setting range all models 20.7 bar (300 PSI) to 206.8 bar (3000 PSI) in standard 3.5 bar (50 PSI) increments
 Maximum input pressure all models 206.8 bar (3000 PSI)
Consult ZF Off-Highway Solutions Minnesota Inc. Applications Department for other available models and application detail.

Tandem Modulating Valves with on/off Pilot

DESCRIPTION

The Tandem Modulating Valves with Pilot function is the same as a mechanically actuated tandem modulating valve. The pilot apply port provides an additional method for on/off brake application through a hydraulic signal from a remote location. Full brake pressure from the pilot apply feature is provided when given the pressure shown in the specifications chart. **Pilot apply is for temporary full apply of the service brakes and not intended for use as a park brake or extended braking.**

For detailed information about principles of operation contact ZF Off-Highway Solutions Minnesota Inc.

Available as valve only, push rod actuated, lever actuated, and pedal actuated. These valves can also be designed with options such as built-in switches, potentiometers, etc.

FEATURES

- Compact size for use in restricted space
- Provides independent braking to front and rear brake systems from one valve
- Oil immersed spring cavity protects return springs from outside contaminants
- Spool design provides smooth modulation at all pressures
- Tank ports communicated internally allow for one or two return lines to tank
- Pilot apply function is provided with zero leakage, low volume actuation
- Pilot apply pressure from a remote location provides a hydraulic signal for on/off brake system pressure

Typical Circuit Schematic

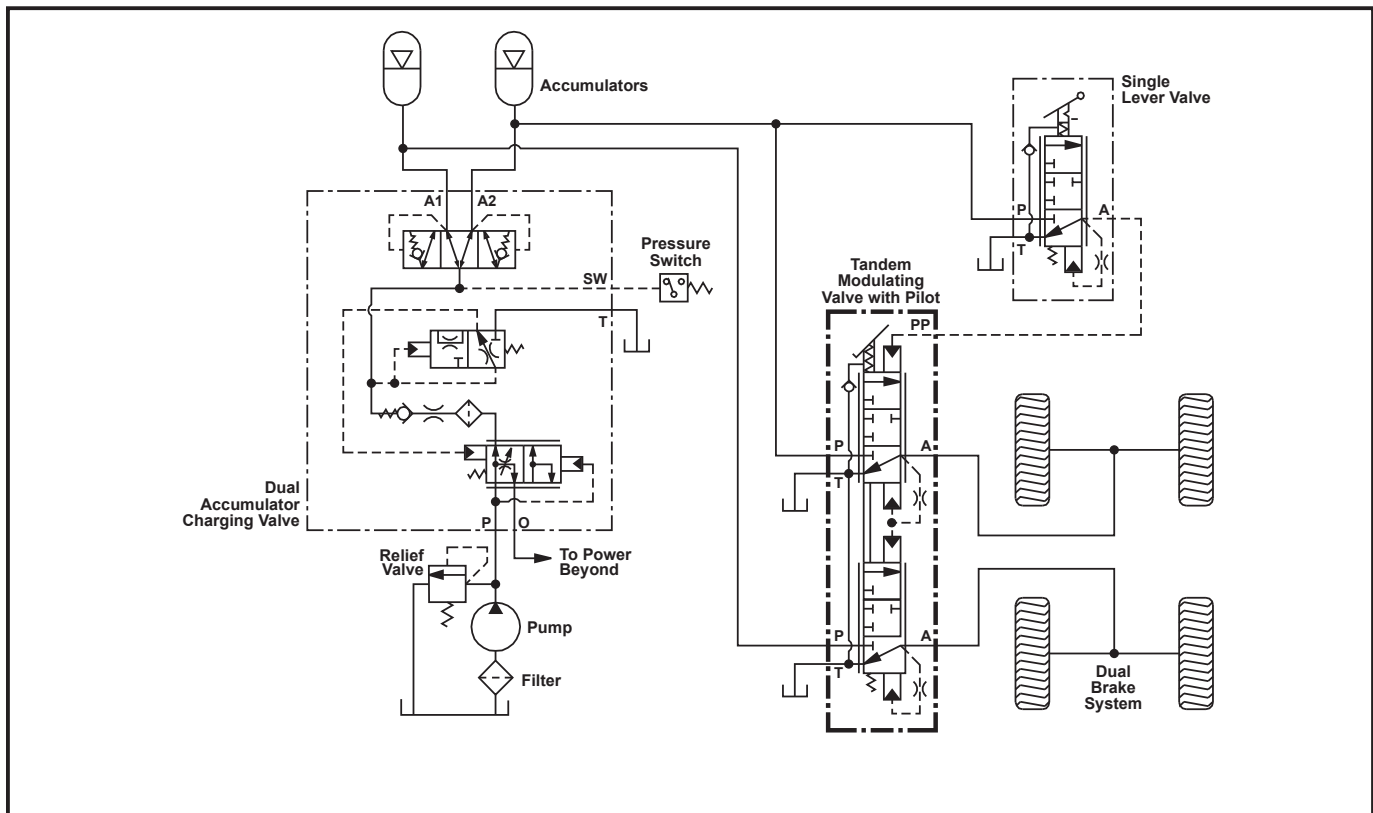

Roller Actuated (tandem with on/off pilot)



Typical Brake Valve

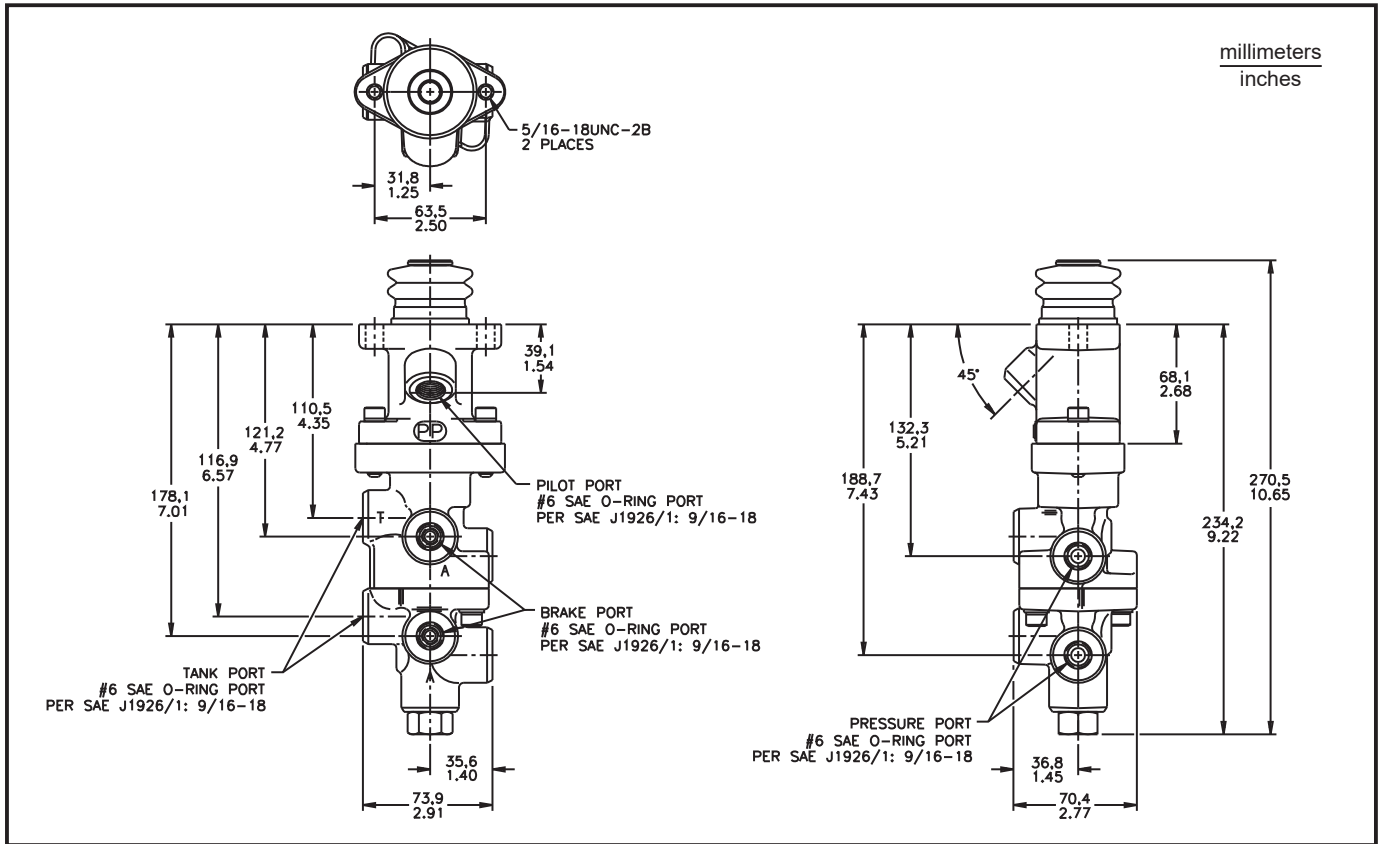

SPECIFICATIONS

Brake pressure setting range all models 20.7 bar (300 PSI) to 206.8 bar (3000 PSI) in standard 3.5 bar (50 PSI) increments
 Maximum input pressure all models 206.8 bar (3000 PSI)
 Consult ZF Off-Highway Solutions Minnesota Inc. Applications Department for other available models and application detail.

Pedal Actuated (tandem with on/off pilot)



Typical Brake Valve

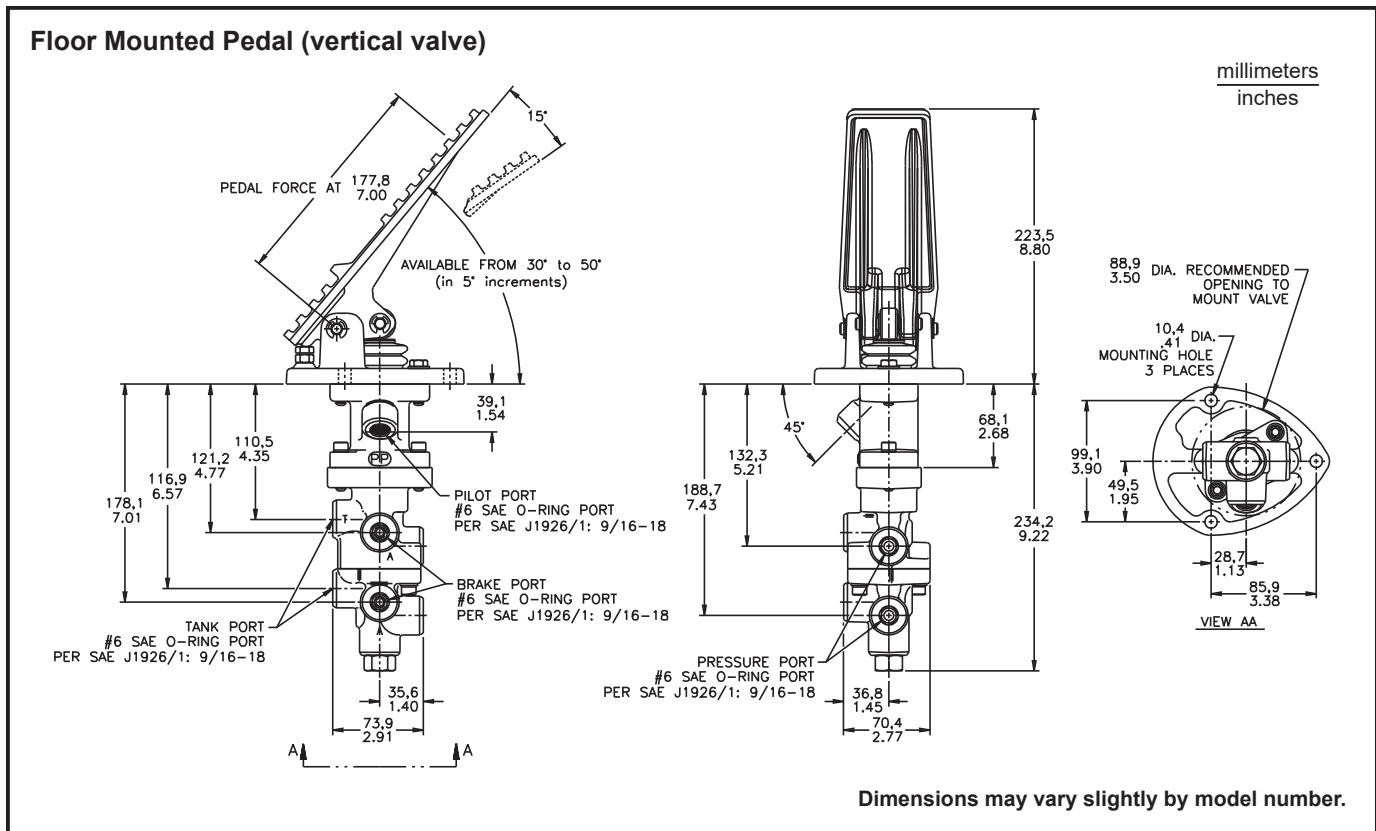

SPECIFICATIONS

Model Number	Catalog Code (refer to page 5)	Nominal Brake Pressure Setting Tolerance		Minimum Pilot Pressure to Fully Apply Brakes	
		bar	(PSI)	bar	(PSI)
06-466-402	PMV-1517TLSS-PS06-T50M-FVNSB	± 6.9	(± 100)	48.3	(700)
06-466-404	PMV-0690TLSS-PS06-T50H-FVNSB	± 5.2	(± 75)	58.6	(850)
06-466-406	PMV-1034TLSS-PS06-T50H-FVNSB	± 5.2	(± 75)	55.2	(800)
06-466-408	PMV-0552TLSS-PS06-T35H-FVNSB	± 5.2	(± 75)	51.7	(750)
06-466-412	PMV-1241TLSS-PS06-T35H-FVNSB	± 6.9	(± 100)	58.6	(850)
06-466-414	PMV-1034TLSS-PS06-T35H-FVNSB	± 5.2	(± 75)	55.2	(800)
06-466-416	PMV-0690TLSS-PS06-T50H-FVNSS	± 5.2	(± 75)	58.6	(850)
06-466-418	PMV-0690TLSS-PS06-T50L-FVNSS	± 5.2	(± 75)	43.1	(625)

Brake pressure setting range all models 20.7 bar (300 PSI) to 206.8 bar (3000 PSI) in standard 3.5 bar (50 PSI) increments

Maximum input pressure all models 206.8 bar (3000 PSI)

Consult ZF Off-Highway Solutions Minnesota Inc. Applications Department for other available models and application detail.

Pedal Actuated (tandem with on/off pilot)



Typical Brake Valve

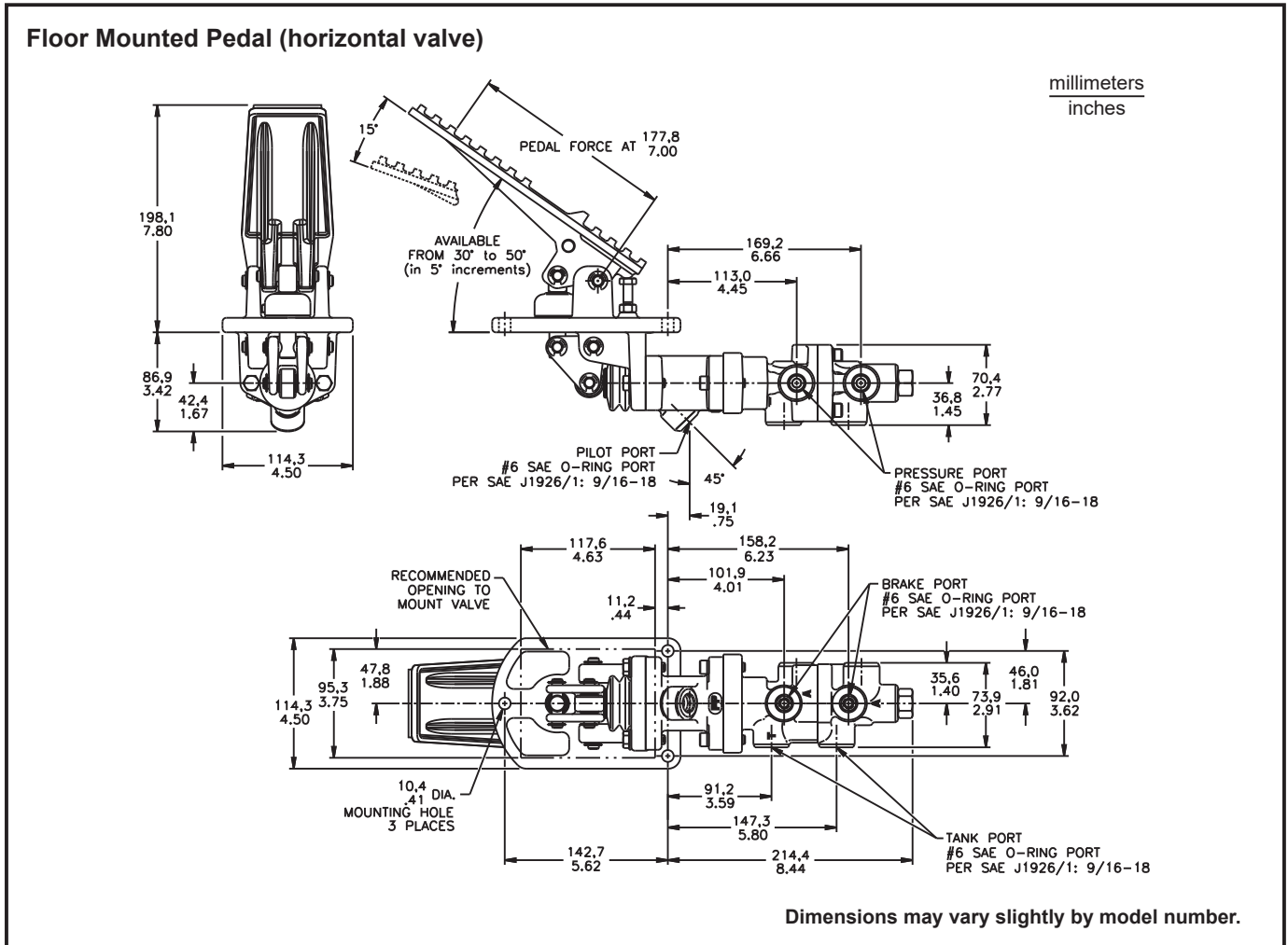

SPECIFICATIONS

Model Number	Catalog Code (refer to page 5)	Nominal Brake Pressure Setting Tolerance		Minimum Pilot Pressure to Fully Apply Brakes	
		bar	(PSI)	bar	(PSI)
06-466-480	PMV-1586TLSS-PS06-T35M-FHNSB	± 6.9	(± 100)	48.3	(700)
06-466-482	PMV-1034TLSS-PS06-T50H-FHNSB	± 5.2	(± 75)	55.2	(800)
06-466-484	PMV-1241TLSS-PS06-T50M-FHNSB	± 6.9	(± 100)	41.4	(600)
06-466-486	PMV-1034TLSS-PS06-T35H-FHNSB	± 5.2	(± 75)	55.2	(800)
06-466-492	PMV-0690TLSS-PS06-T35M-FHNSB	± 5.2	(± 75)	58.6	(850)

Brake pressure setting range all models 20.7 bar (300 PSI) to 206.8 bar (3000 PSI) in standard 3.5 bar (50 PSI) increments
 Maximum input pressure all models 206.8 bar (3000 PSI)

Consult ZF Off-Highway Solutions Minnesota Inc. Applications Department for other available models and application detail.

Pedal Actuated (tandem with on/off pilot)



Typical Brake Valve

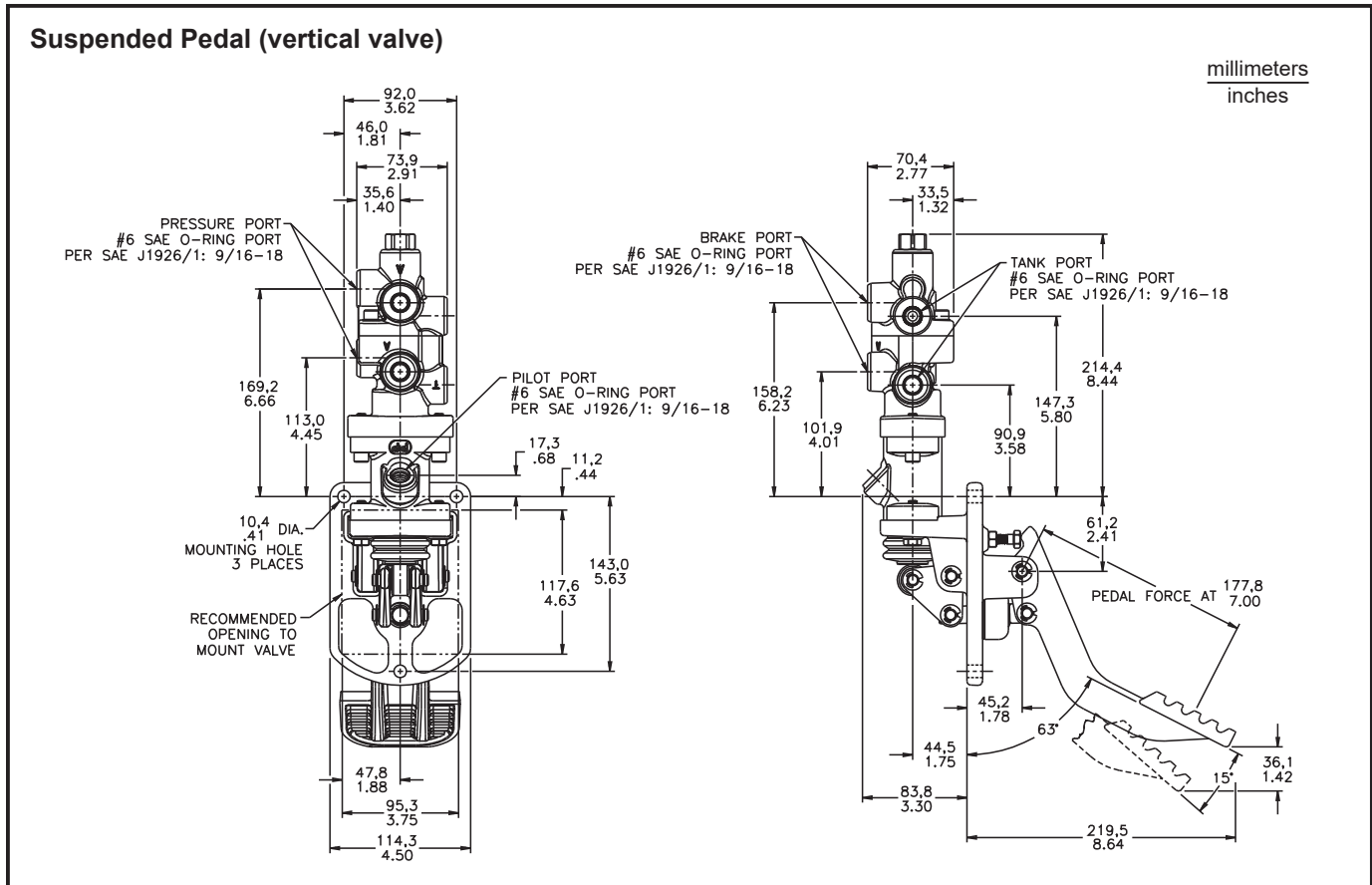

SPECIFICATIONS

Model Number	Catalog Code (refer to page 5)	Nominal Brake Pressure Setting Tolerance		Minimum Pilot Pressure to Fully Apply Brakes	
		bar	(PSI)	bar	(PSI)
06-466-410	PMV-1034TLSS-PS06-SNNH-WVNSS	± 5.2	(± 75)	55.2	(800)

Brake pressure setting range all models 20.7 bar (300 PSI) to 206.8 bar (3000 PSI) in standard 3.5 bar (50 PSI) increments

Maximum input pressure all models 206.8 bar (3000 PSI)

Consult ZF Off-Highway Solutions Minnesota Inc. Applications Department for other available models and application detail.

Pedal Actuated (tandem with on/off pilot and switch)



Typical Brake Valve

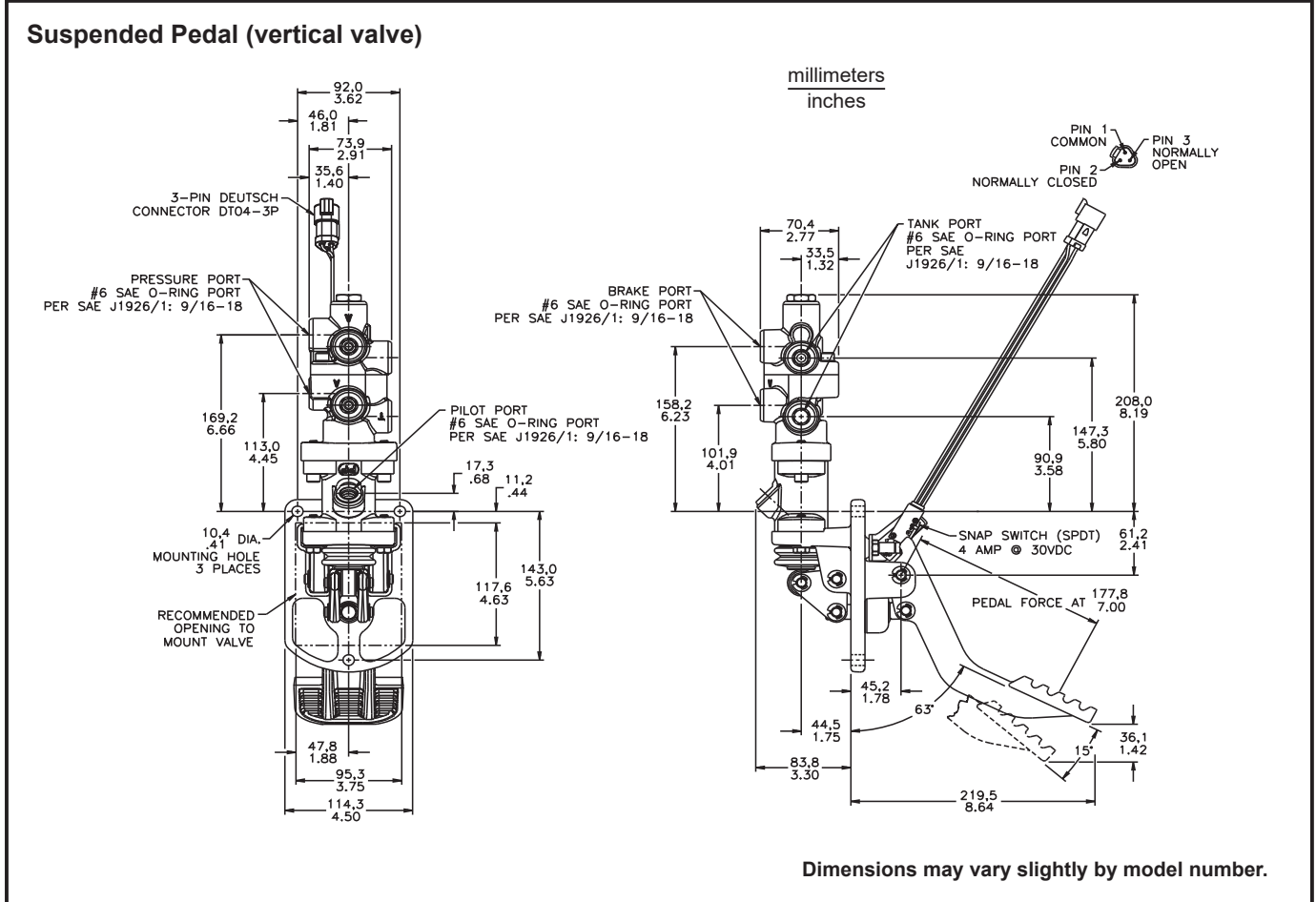

SPECIFICATIONS

Model Number	Catalog Code (refer to page 5)	Nominal Brake Pressure Setting Tolerance		Minimum Pilot Pressure to Fully Apply Brakes	
		bar	(PSI)	bar	(PSI)
06-466-403	PMV-0579TSMSPS08-SNNH-WVWSS	+2.1	(+30)	49.6	(720)
06-466-948	PMV-0600TLSS-PS06-SNNH-WVWSS	± 5.2	(± 75)	54.1	(785)

Brake pressure setting range all models 20.7 bar (300 PSI) to 206.8 bar (3000 PSI) in standard 3.5 bar (50 PSI) increments
 Maximum input pressure all models 206.8 bar (3000 PSI)
 Consult ZF Off-Highway Solutions Minnesota Inc. Applications Department for other available models and application detail.

(spool design)

Tandem Modulating Valves with Proportional Pilot

DESCRIPTION

The Tandem Modulating Valves with Pilot function is the same as a mechanically actuated tandem modulating valve with an added hydraulic pilot apply port. The pilot apply provides an additional method for direct acting, proportional brake application at a one-to-one ratio through a hydraulic signal from a remote location. Pilot apply gives the operator a "pedal feel" proportional to brake system pressure.

For detailed information about principles of operation contact ZF Off-Highway Solutions Minnesota Inc..

Available as valve only, push rod actuated, lever actuated, and pedal actuated. These valves can also be designed with options such as built-in switches, potentiometers, etc.

FEATURES

- Compact size for use in restricted space
- Provides independent braking to front and rear brake systems from one valve
- Oil immersed spring cavity protects return springs from outside contaminants
- Spool design provides smooth modulation at all pressures
- Tank ports communicated internally allow for one or two return lines to tank
- Pilot apply pressure is controlled by a full power valve such as a Single Modulating Valve
- Pilot apply pressure is a one-to-one ratio to brake system pressure

Typical Circuit Schematic

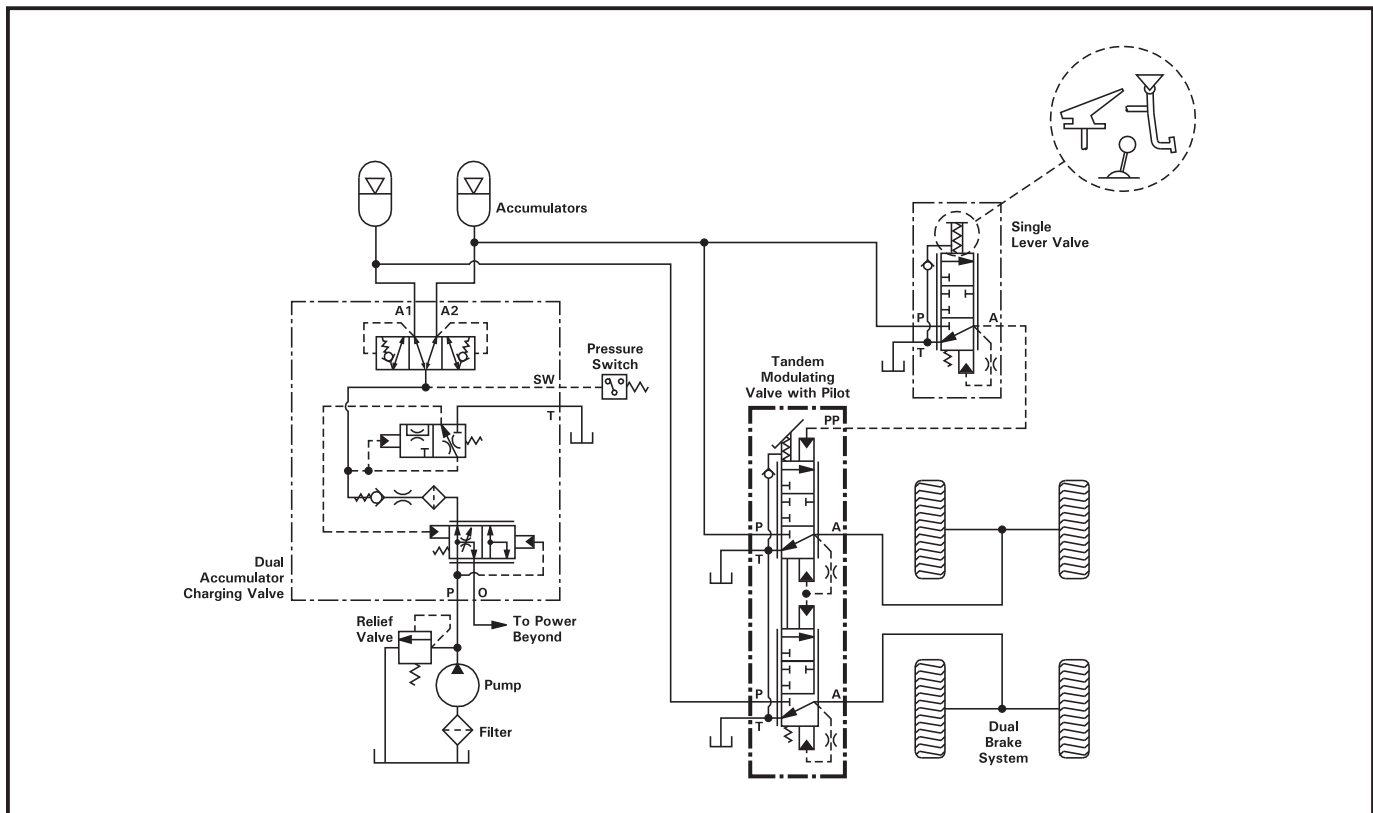

Roller Actuated (tandem with proportional pilot)



Typical Brake Valve

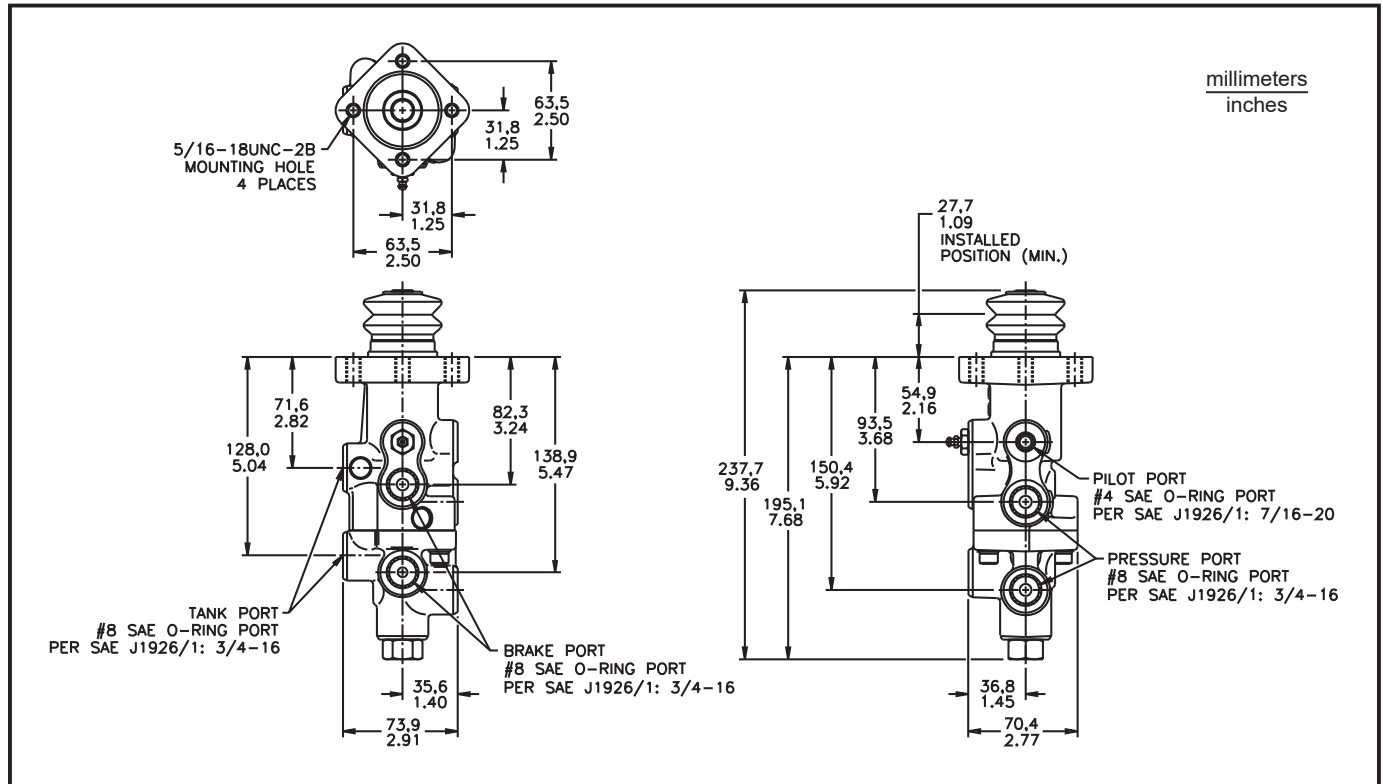

SPECIFICATIONS

Model Number	Catalog Code (refer to page 5)	Nominal Brake Pressure Setting Tolerance		Minimum Pilot Pressure to Fully Apply Brakes		Approximate Input Force at Pressure Setting	
		bar	(PSI)	bar	(PSI)	N	(lb)
20-100-802	PMO-0776TLMS-N008-R	± 5.2	(± 75)	77.6	(1125)	1180	(265)

Brake pressure setting range all models 20.7 bar (300 PSI) to 206.8 bar (3000 PSI) in standard 3.5 bar (50 PSI) increments
 Maximum input pressure all models 206.8 bar (3000 PSI)
Consult ZF Off-Highway Solutions Minnesota Inc. Applications Department for other available models and application detail.

Pedal Actuated (tandem with proportional pilot)



Typical Brake Valve

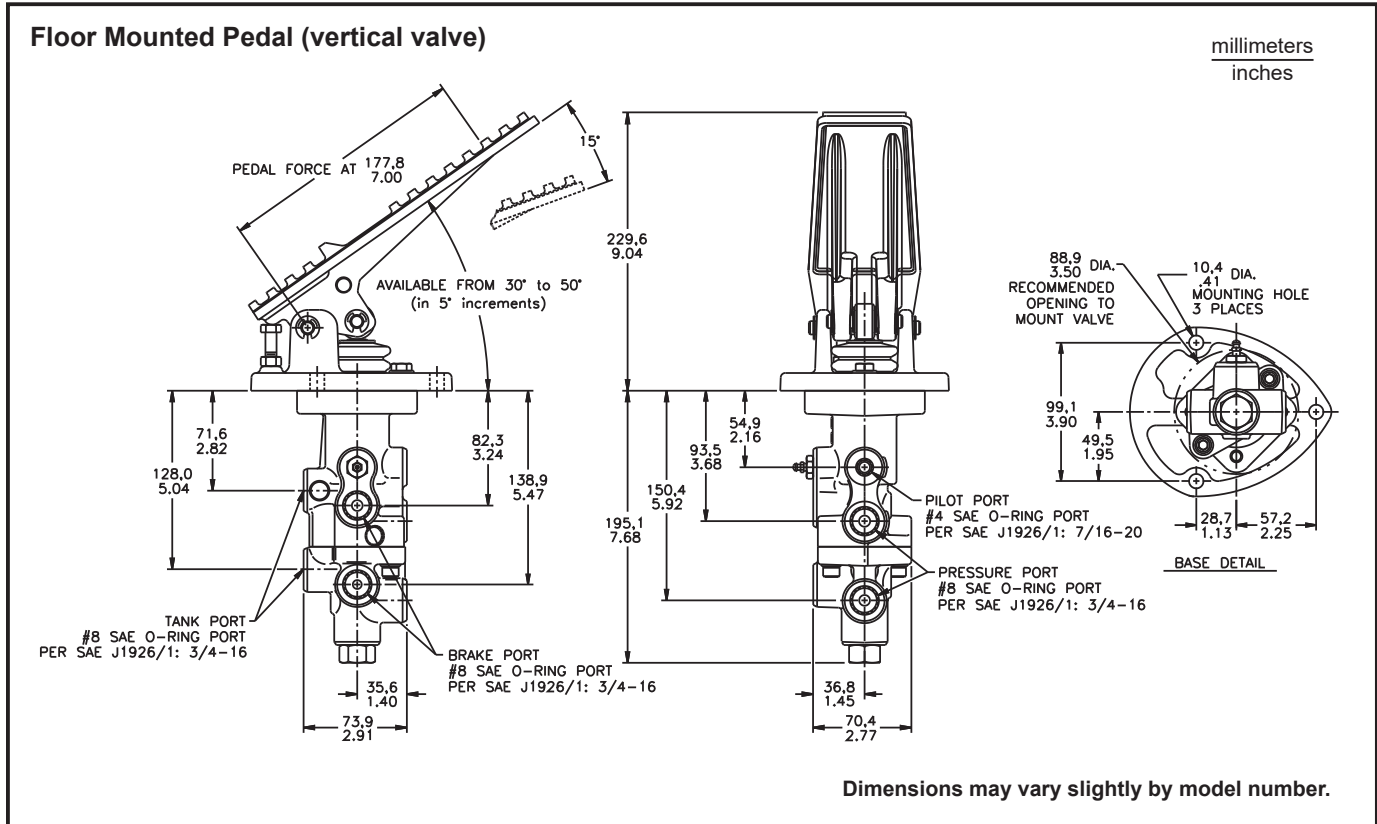

SPECIFICATIONS

Model Number	Catalog Code (refer to page 5)	Nominal Brake Pressure Setting Tolerance		Minimum Pilot Pressure to Fully Apply Brakes	
		bar	(PSI)	bar	(PSI)
06-466-947	PMV-0448TLMS-PS08-T35M-FVNSB	± 3.5	(± 50)	44.8	(650)
06-466-954	PMV-0776TSMS-PS08-T35M-FVNSB	± 5.2	(± 75)	77.6	(1125)
06-466-970	PMV-0400TSMS-PS08-T35L-FVNSB	± 3.5	(± 50)	40.0	(580)
06-466-992	PMV-0600TSMS-PS08-T35L-FVNSB	± 3.5	(± 50)	60.0	(870)

Brake pressure setting range all models 20.7 bar (300 PSI) to 206.8 bar (3000 PSI) in standard 3.5 bar (50 PSI) increments
 Maximum input pressure all models 206.8 bar (3000 PSI)

Consult ZF Off-Highway Solutions Minnesota Inc. Applications Department for other available models and application detail.

Pedal Actuated (tandem with proportional pilot)



Typical Brake Valve

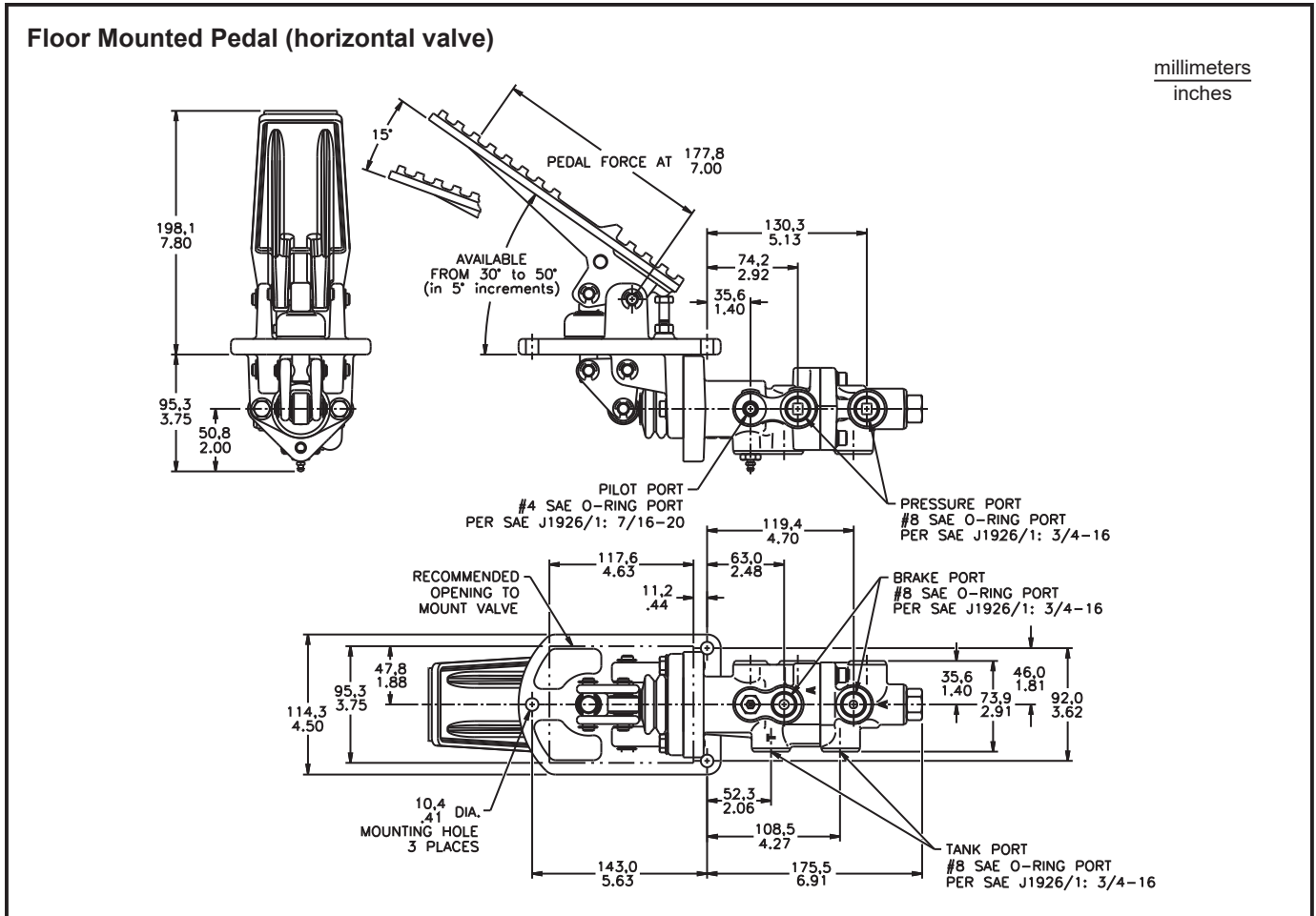

SPECIFICATIONS

Model Number	Catalog Code (refer to page 5)	Nominal Brake Pressure Setting Tolerance		Minimum Pilot Pressure to Fully Apply Brakes	
		bar	(PSI)	bar	(PSI)
06-466-960	PMV-0776TSMS-PS08-T35M-FHNSB	± 5.2	(± 75)	77.6	(1125)

Brake pressure setting range all models 20.7 bar (300 PSI) to 206.8 bar (3000 PSI) in standard 3.5 bar (50 PSI) increments
 Maximum input pressure all models 206.8 bar (3000 PSI)
Consult ZF Off-Highway Solutions Minnesota Inc. Applications Department for other available models and application detail.

(poppet design)

Single Modulating Valves

DESCRIPTION

These Single Modulating Valves are a closed center poppet design. They provide a modulated output pressure of up to 206.8 bar (3000 PSI) and a maximum input pressure of 206.8 bar (3000 PSI). Standard brake pressure settings are in increments of 3.5 bar (50 PSI).

The poppet design modulating valves are capable of higher flow capacity than the spool design modulating valves. The poppet design also allows for virtually zero internal leakage compared to the spool design. For detailed information about principles of operation contact Zf Off-Highway Solutions Minnesota Inc.

Available as valve only, push rod actuated, and pedal actuated. These valves can also be designed with options such as built-in switches, potentiometers, etc.

FEATURES

- Poppet design provides for virtually zero leakage
- High capacity fluid displacement
- Oil immersed spring cavity protects return springs from outside contaminants

Typical Circuit Schematic

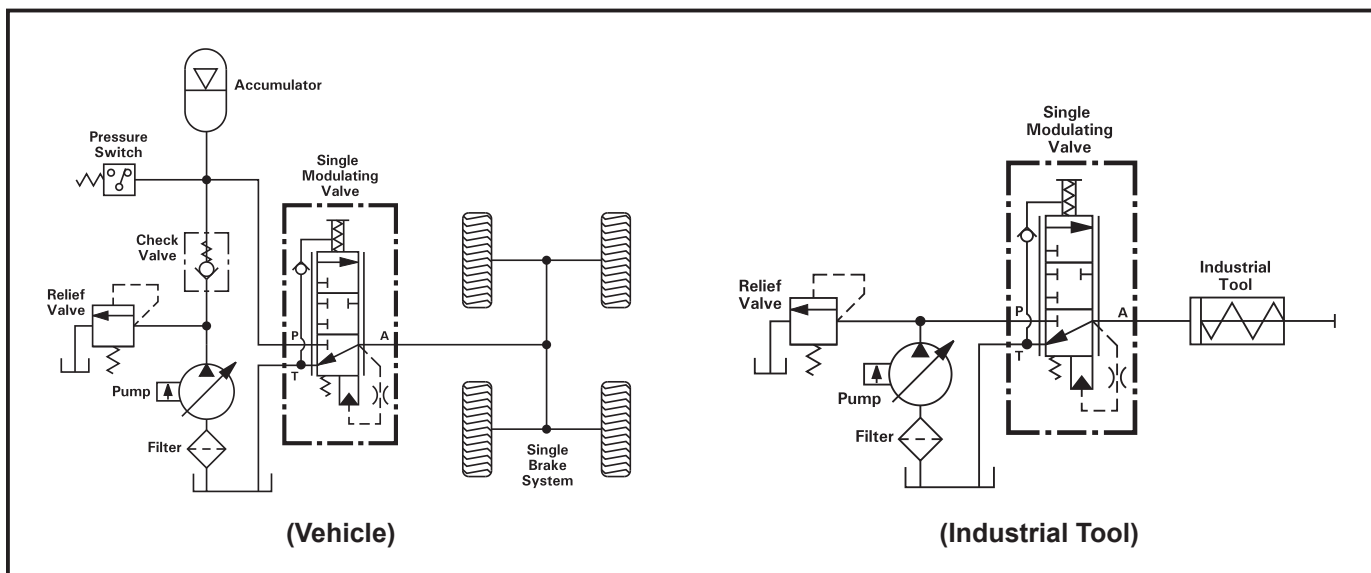

Push Rod Actuated (single)



Typical Brake Valve

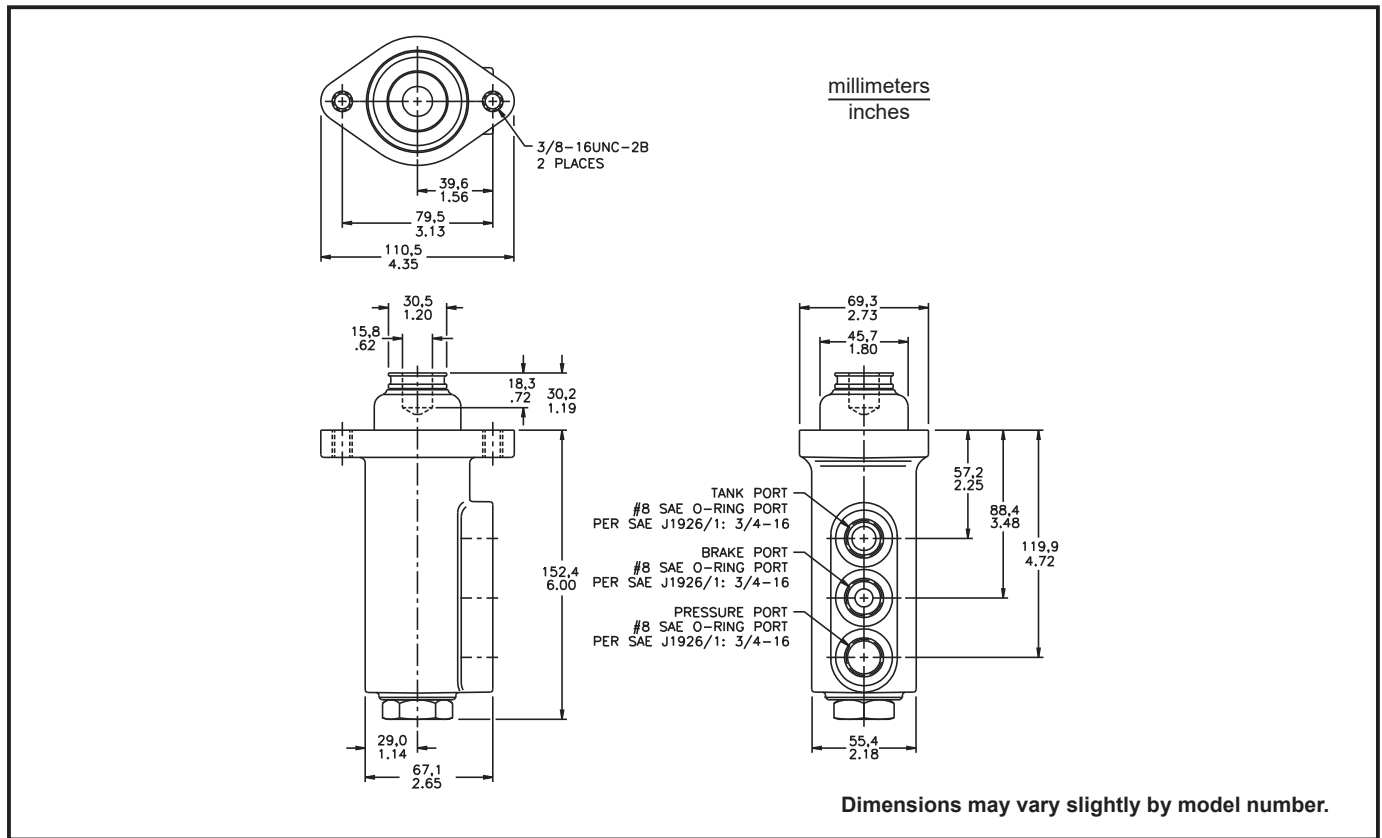

SPECIFICATIONS (no corresponding catalog code for these model numbers)

Model Number	Nominal Brake Pressure Setting Tolerance		Push Rod Force at Pressure Setting	
	bar	(PSI)	N	(lb)
06-460-302	124.1 ± 1.7	(1800 ± 25)	1534.6	(345)
06-460-304	103.4 ± 1.7	(1500 ± 25)	1334.5	(300)
06-460-306	32.8 ± 1.7	(475 ± 25)	1378.9	(310)
06-460-308	65.5 ± 1.7	(950 ± 25)	4114.6	(925)
06-460-310	81.0 ± 3.5	(1175 ± 50)	2980.3	(670)
06-460-312	22.4 ± 1.7	(325 ± 25)	1601.4	(360)
06-460-314	103.4 ± 3.5	(1500 ± 50)	3558.6	(800)
06-460-316	43.1 ± 1.7	(625 ± 25)	2980.3	(670)
06-460-318	206.8 ± 3.5	(3000 ± 50)	2335.3	(525)
06-460-338	103.4 ± 1.7	(1500 ± 25)	2268.6	(510)
06-460-340	55.2 ± 1.7	(800 ± 25)	1423.4	(320)
06-460-342	77.2 ± 3.5	(1120 ± 50)	2757.9	(620)
06-460-346	137.9 ± 3.5	(2000 ± 50)	2313.1	(520)
06-460-348	31.0 ± 1.7	(450 ± 25)	2201.9	(495)
06-460-352	63.8 ± 1.7	(925 ± 25)	1601.4	(360)
06-460-354	63.8 ± 1.7	(925 ± 25)	2290.8	(515)
06-460-356	69.0 ± 3.5	(1000 ± 50)	2491.0	(560)
06-460-358	24.1 ± 1.5	(350 ± 20)	1672.5	(376)

Brake pressure setting range all models 20.7 bar (300 PSI) to 206.8 bar (3000 PSI) in standard 3.5 bar (50 PSI) increments
 Maximum input pressure all models 206.8 bar (3000 PSI)

Consult ZF Off-Highway Solutions Minnesota Inc. Applications Department for other available models and application detail.

Pedal Actuated (single)



Typical Brake Valve

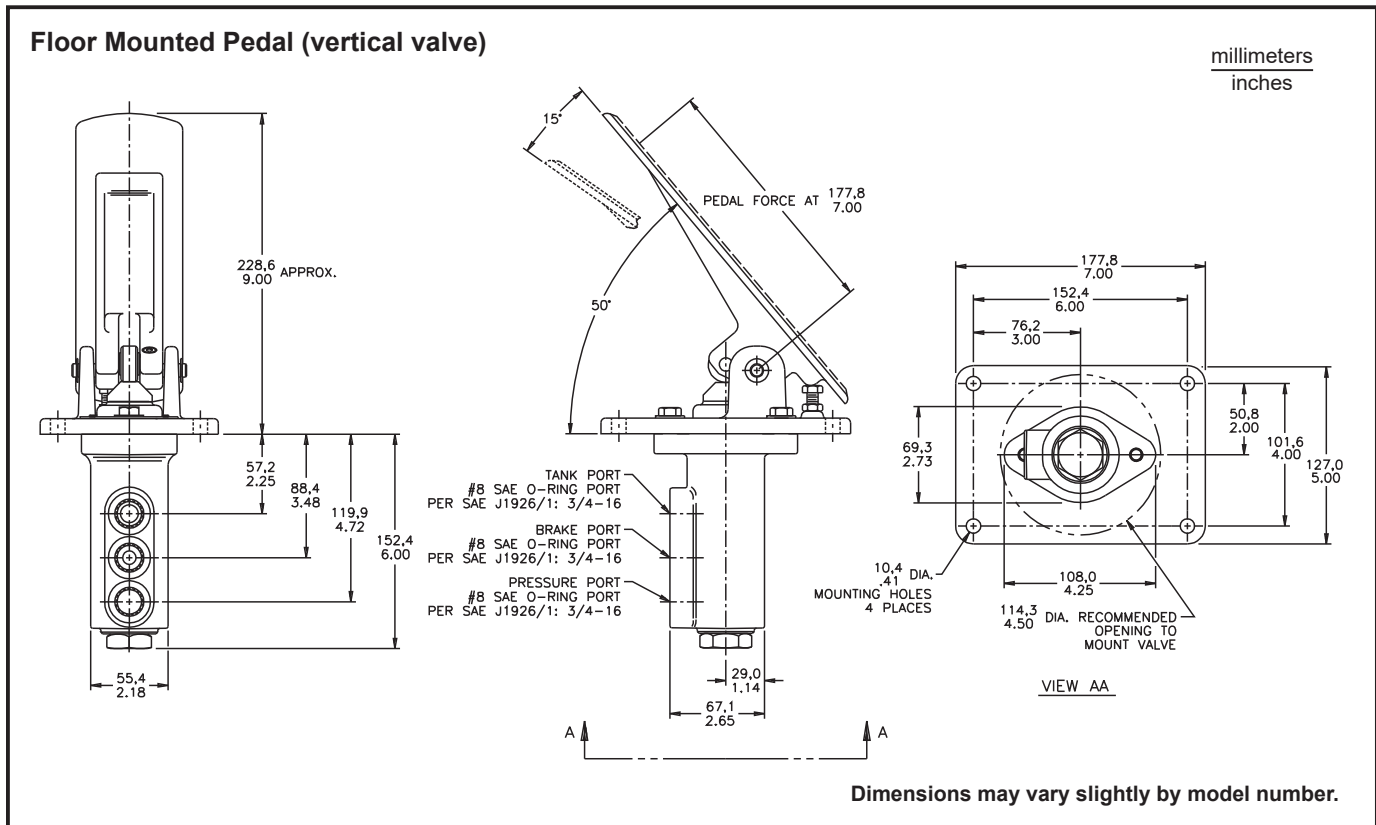

SPECIFICATIONS (no corresponding catalog code for these model numbers)

Model Number	Brake Pressure Setting		Approximate Pedal Force at Pressure Setting	
	bar	(PSI)	N	(lb)
06-460-380	103.4 ± 3.5	(1500 ± 50)	191.3	(43)
06-460-382	206.8 ± 3.5	(3000 ± 50)	289.1	(65)
06-460-384	34.5 ± 1.7	(500 ± 25)	342.5	(77)
06-460-386	48.3 ± 1.4	(700 ± 20)	298.0	(67)
06-460-388	79.3 ± 3.5	(1150 ± 50)	271.3	(61)
06-460-390	25.9 ± 1.7	(375 ± 25)	266.9	(60)
06-460-392	50.0 ± 3.5	(725 ± 50)	458.2	(103)

Brake pressure setting range all models 20.7 bar (300 PSI) to 206.8 bar (3000 PSI) in standard 3.5 bar (50 PSI) increments

Maximum input pressure all models 206.8 bar (3000 PSI)

Consult ZF Off-Highway Solutions Minnesota Inc. Applications Department for other available models and application detail.

Pedal Actuated (two single valves)



Typical Brake Valve

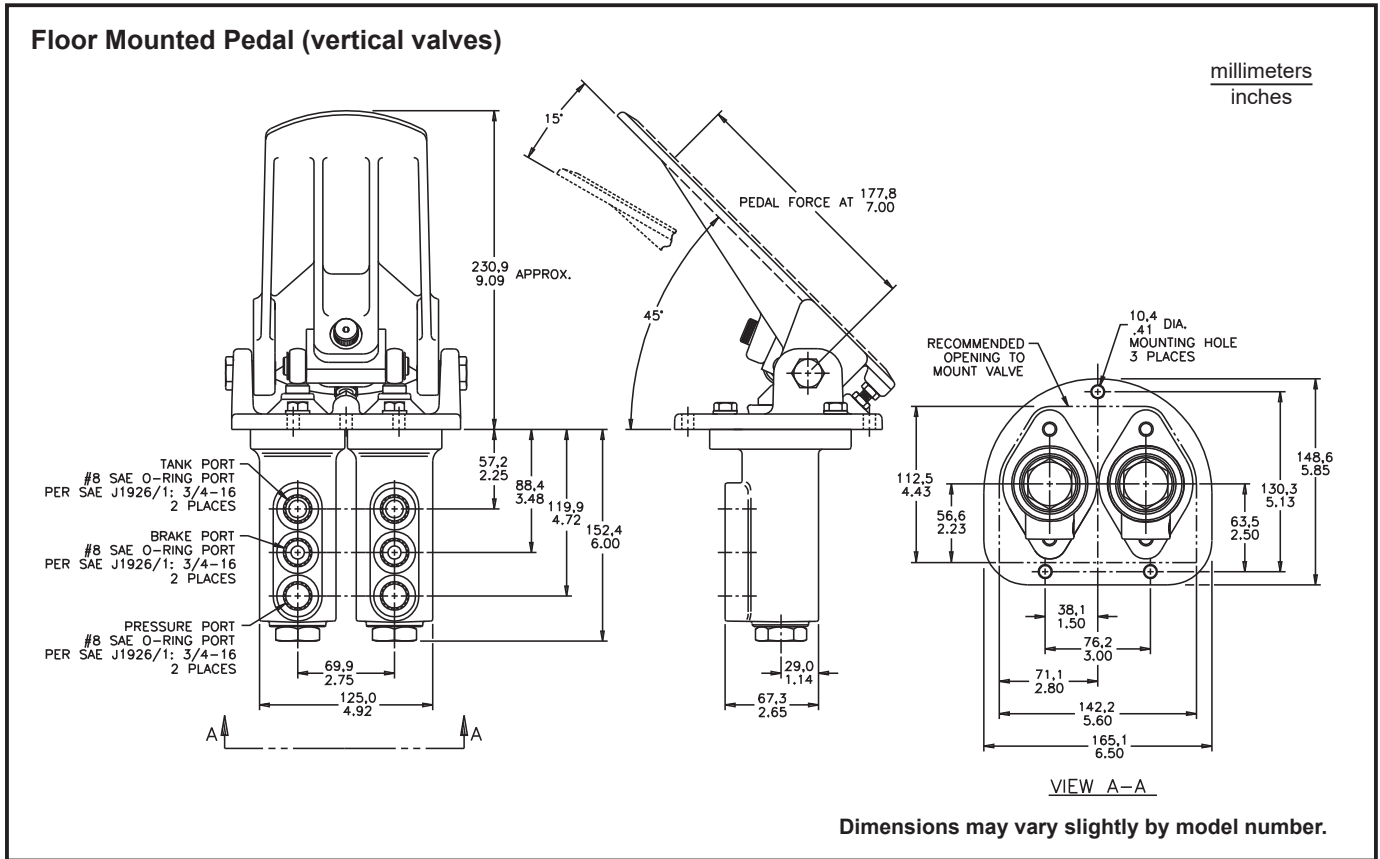

SPECIFICATIONS (no corresponding catalog code for these model numbers)

Model Number	Brake Pressure Setting (both valves)		Approximate Pedal Force at Pressure Setting	
	bar	(PSI)	N	(lb)
06-462-348	69.0 ± 5.2	(1000 ± 75)	244.7	(55)
06-462-350	103.4 ± 1.7	(1500 ± 25)	333.6	(75)
06-462-354	124.1 ± 1.7	(1800 ± 25)	400.3	(90)
06-462-356	84.5 ± 1.7	(1225 ± 25)	289.1	(65)
06-462-360	151.7 ± 3.5	(2200 ± 50)	311.4	(70)
06-462-364	22.4 ± 1.7	(325 ± 25)	266.9	(60)

Brake pressure setting range all models 20.7 bar (300 PSI) to 206.8 bar (3000 PSI) in standard 3.5 bar (50 PSI) increments
 Maximum input pressure all models 206.8 bar (3000 PSI)

Consult ZF Off-Highway Solutions Minnesota Inc. Applications Department for other available models and application detail.

(poppet design)

Two Single Modulating Valves with Pilot

PRINCIPLES OF OPERATION

These Single Modulating Valves with Pilot are a combination of a single modulating valve and a hydraulic pilot section. The pilot apply provides an additional method for brake application through a hydraulic signal from a remote location. Two independent valves share a single pedal. They provide a modulated output pressure of up to 206.8 bar (3000 PSI) and a maximum input pressure of 206.8 bar (3000 PSI). Standard brake pressure settings are in increments of 3.5 bar (50 PSI).

The poppet design modulating valves are capable of higher flow capacity than the spool design modulating valves. The poppet design also allows for virtually zero internal leakage compared to the spool design. For detailed information about principles of operation contact ZF Off-Highway Solutions Minnesota Inc.

Available as valve only, push rod actuated, and pedal actuated. These valves can also be designed with options such as built-in switches, potentiometers, etc.

FEATURES

- Poppet design provides for virtually zero leakage
- High capacity fluid displacement
- Oil immersed spring cavity protects return springs from outside contaminants
- Provides independent braking to front and rear brake systems
- Pilot apply function is provided with zero leakage, low volume actuation

Typical Circuit Schematic

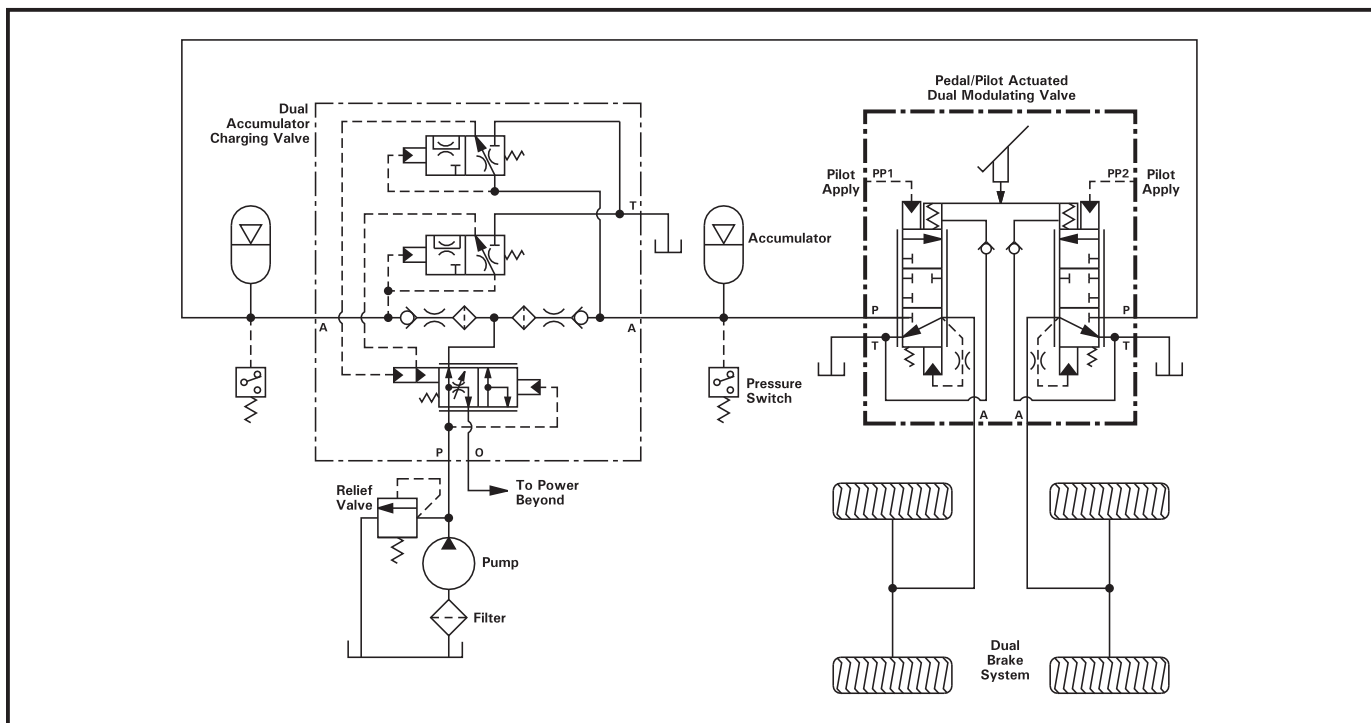

Pedal Actuated (two single valves with pilot)



Typical Brake Valve

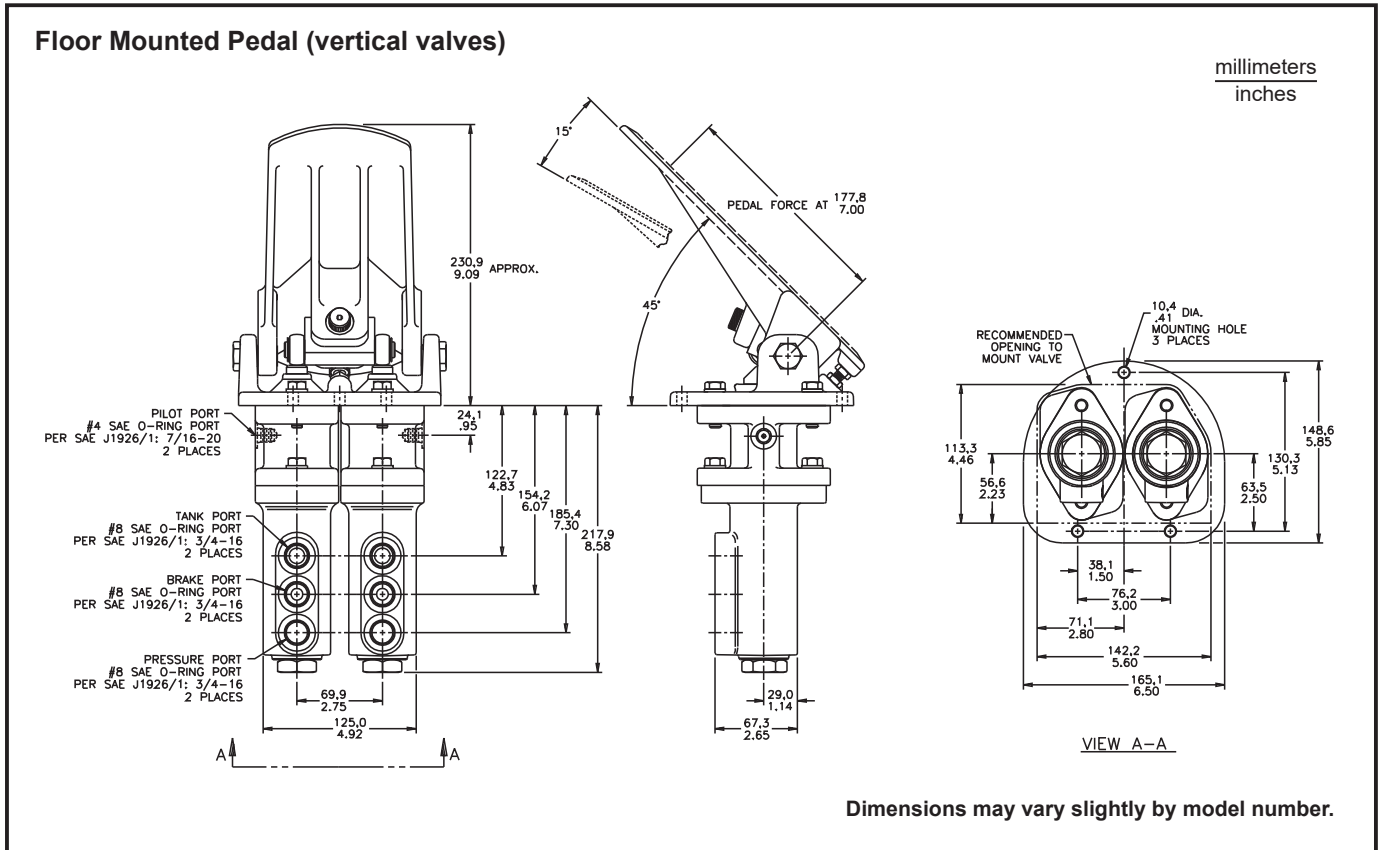

SPECIFICATIONS (no corresponding catalog code for these model numbers)

Model Number	Brake Pressure Setting (both valves)		Pilot Pressure to Fully Apply Brakes		Approximate Pedal Force at Pressure Setting	
	bar	(PSI)	bar	(PSI)	N	(lb)
06-460-406	82.7 ± 3.5	(1200 ± 50)	34.5	(500)	289.1	(65)
06-460-412	94.0 ± 2.6	(1363 ± 37)	37.9	(550)	289.1	(65)

Brake pressure setting range all models 20.7 bar (300 PSI) to 206.8 bar (3000 PSI) in standard 3.5 bar (50 PSI) increments
 Maximum input pressure all models 206.8 bar (3000 PSI)

Consult ZF Off-Highway Solutions Minnesota Inc. Applications Department for other available models and application detail.

(spool design)

Reverse Modulating Valves

DESCRIPTION

These Reverse Modulating Valves can be used in negative braking systems to actuate a spring apply/hydraulic release service brake. The term “reverse modulating” is used because pressure is decreased to actuate the brake from a preset pressure that keeps the brake fully released. The preset pressure is regulated to a level above the full release pressure of the brake and must be maintained to assure that brake drag does not occur.

To actuate the spring apply/hydraulic release brake, apply the brake pedal and hydraulic pressure in the brake system is reduced causing the springs to apply the brake. Brake pedal position and force is proportional to the brake system pressure and provides the feedback necessary for good braking control.

Models are available with a latched pedal design for use in parking and/or dynamic braking.

FEATURES

- Compact size for use in restricted spaces
- Oil immersed spring cavity protects return springs from outside contaminants
- Spool design provides smooth modulation at all pressures

Typical Circuit Schematic

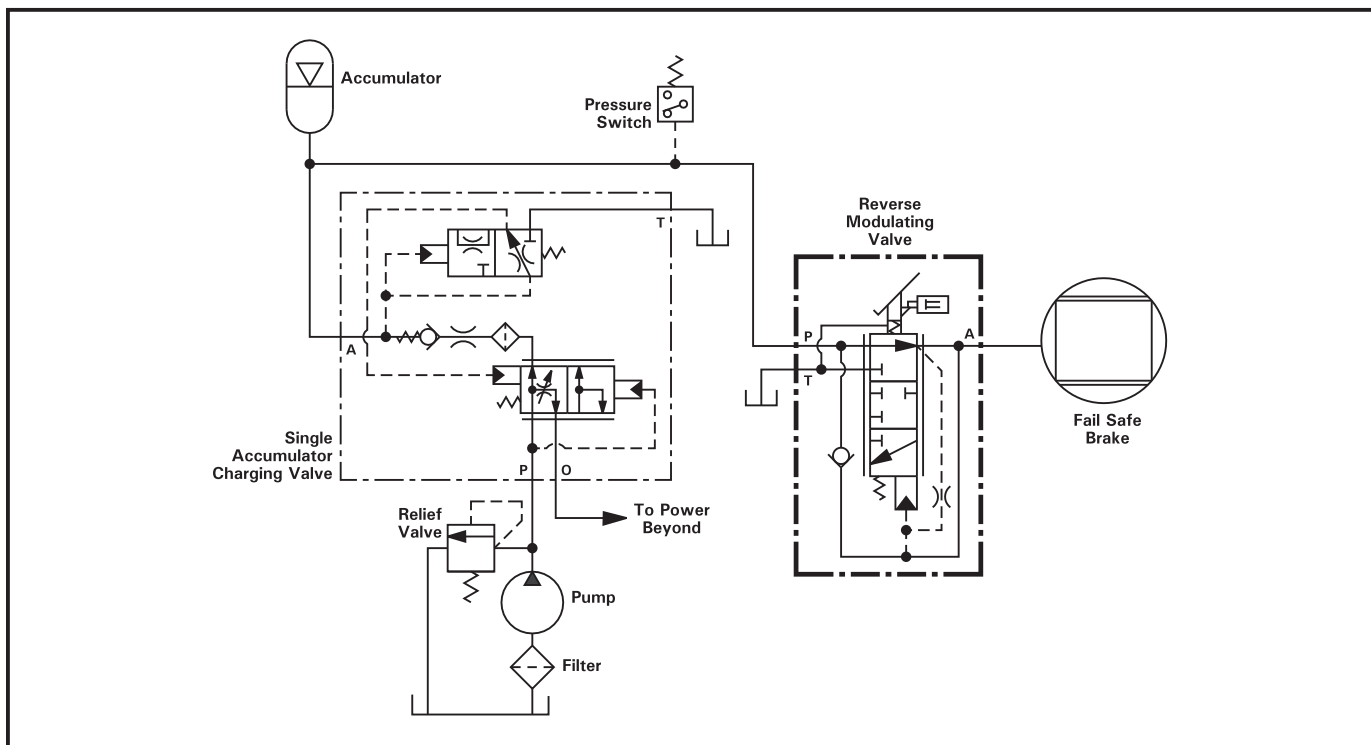

Pull Actuated (reverse modulating)



Typical Brake Valve

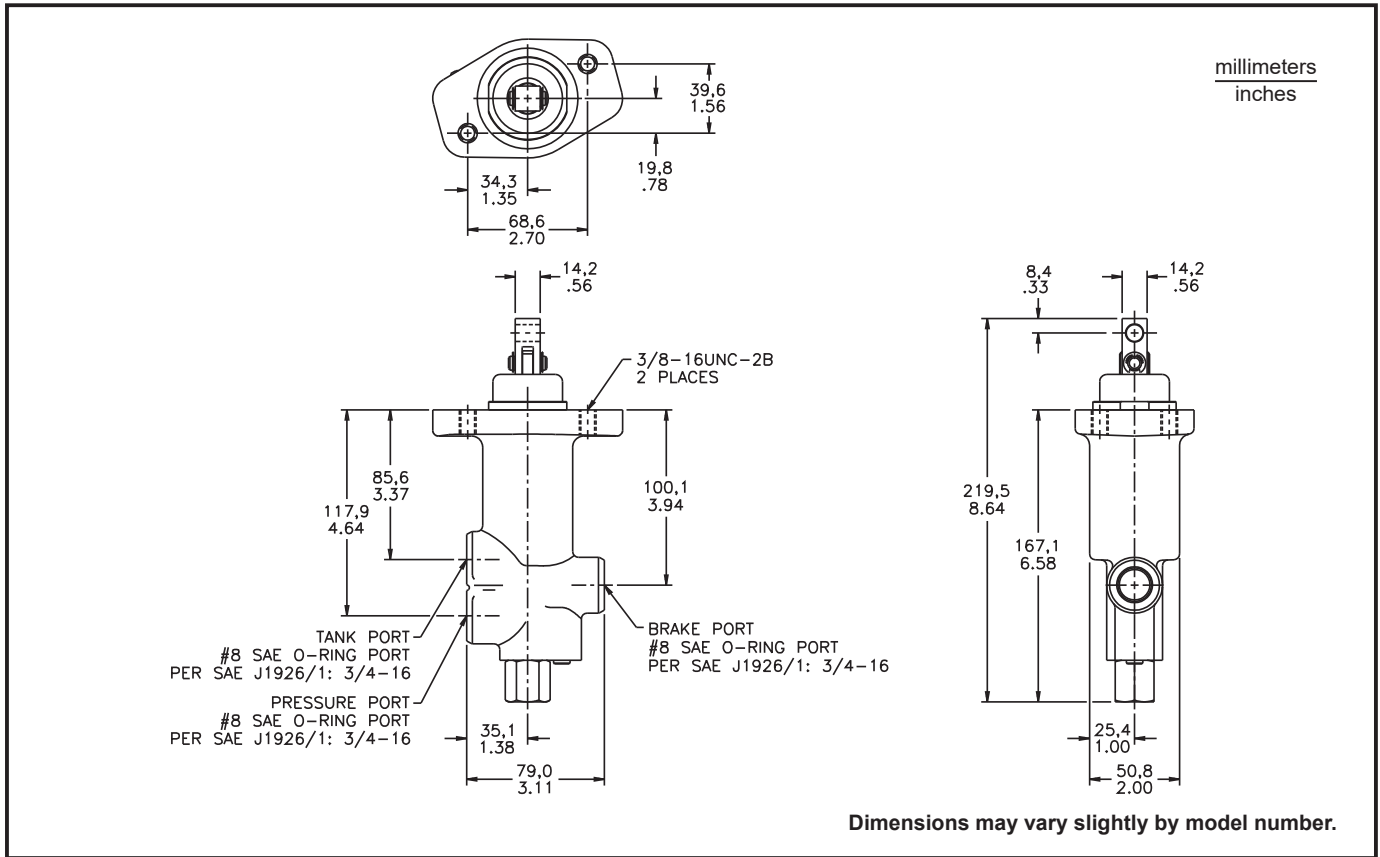

SPECIFICATIONS (no corresponding catalog code for these model numbers)

Model Number	Brake Pressure Setting		Approximate Pull Force at Zero Pressure		Maximum Pull Travel	
	bar	(PSI)	N	(lb)	mm	(inch)
20-100-506	86.2 ± 3.5	(1250 ± 50)	2669.0	(600)	7.9	(0.31)
20-100-556	72.4 ± 3.5	(1050 ± 50)	2669.0	(600)	7.9	(0.31)
20-100-959	117.2 ± 3.5	(1700 ± 50)	1334.5	(300)	7.9	(0.31)
20-100-990	25.2 ± 1.0	(365 ± 15)	1134.3	(225)	7.9	(0.31)

Brake pressure setting range all models 20.7 bar (300 PSI) to 206.8 bar (3000 PSI) in standard 3.5 bar (50 PSI) increments

Maximum input pressure all models 206.8 bar (3000 PSI)

Consult ZF Off-Highway Solutions Minnesota Inc. Applications Department for other available models and application detail.

Pedal Actuated (reverse modulating)



Typical Brake Valve

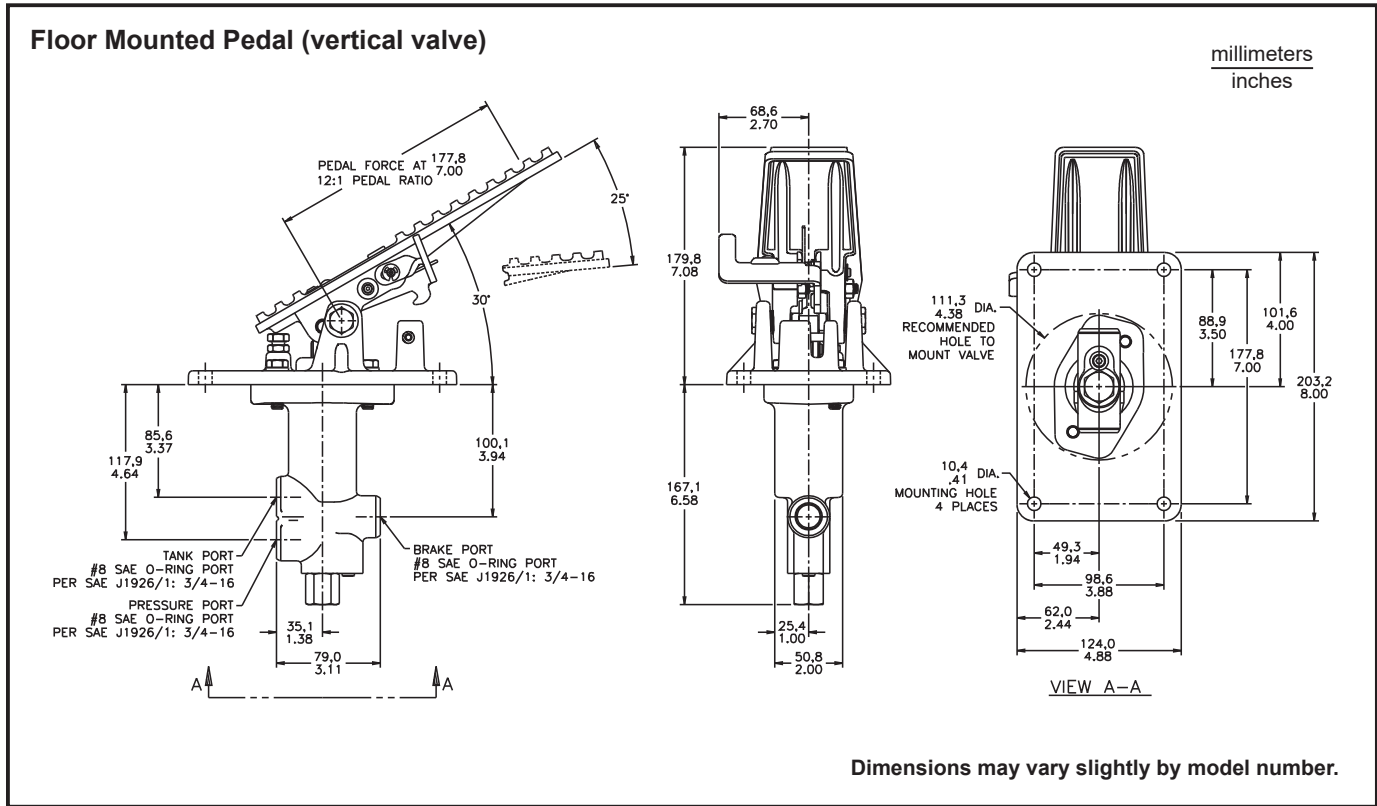

SPECIFICATIONS (no corresponding catalog code for these model numbers)

Model Number	Brake Pressure Setting		Approximate Pedal Force at Zero Pressure	
	bar	(PSI)	N	(lb)
03-460-400	86.2 ± 3.5	(1250 ± 50)	169.0	(38)
03-460-402	17.2 ± 1.4	(250 ± 120)	231.3	(52)
03-460-404	103.4 ± 3.5	(1500 ± 50)	249.1	(56)
03-460-406	22.1 ± 1.4	(320 ± 20)	231.3	(52)
03-460-410	137.9 ± 6.9	(2000 ± 100)	249.1	(56)
03-460-412	172.4 ± 6.9	(2500 ± 100)	249.1	(56)
* 03-460-420	110.3 ± 3.5	(1600 ± 50)	249.1	(56)
* 03-460-426	117.2 ± 3.5	(1700 ± 50)	249.1	(56)
03-460-428	37.9 ± 3.5	(550 ± 50)	231.3	(52)
03-460-430	22.1 ± 1.4	(320 ± 20)	231.3	(52)
* 03-460-432	31.0 ± 1.4	(450 ± 20)	182.4	(41)
* 03-460-433	103.4 ± 3.5	(1500 ± 50)	258.0	(58)
* 03-460-442	137.9 ± 6.9	(2000 ± 50)	249.1	(56)
03-460-448	117.2 ± 3.5	(1700 ± 50)	231.3	(56)
* 03-460-449	155.1 ± 5.2	(2250 ± 75)	249.1	(56)

* Pedal has no latch.

Brake pressure setting range all models 20.7 bar (300 PSI) to 206.8 bar (3000 PSI) in standard 3.5 bar (50 PSI) increments
 Maximum input pressure all models 206.8 bar (3000 PSI)

Consult ZF Off-Highway Solutions Minnesota Inc. Applications Department for other available models and application detail.

Pedal Actuated (reverse modulating)



Typical Brake Valve

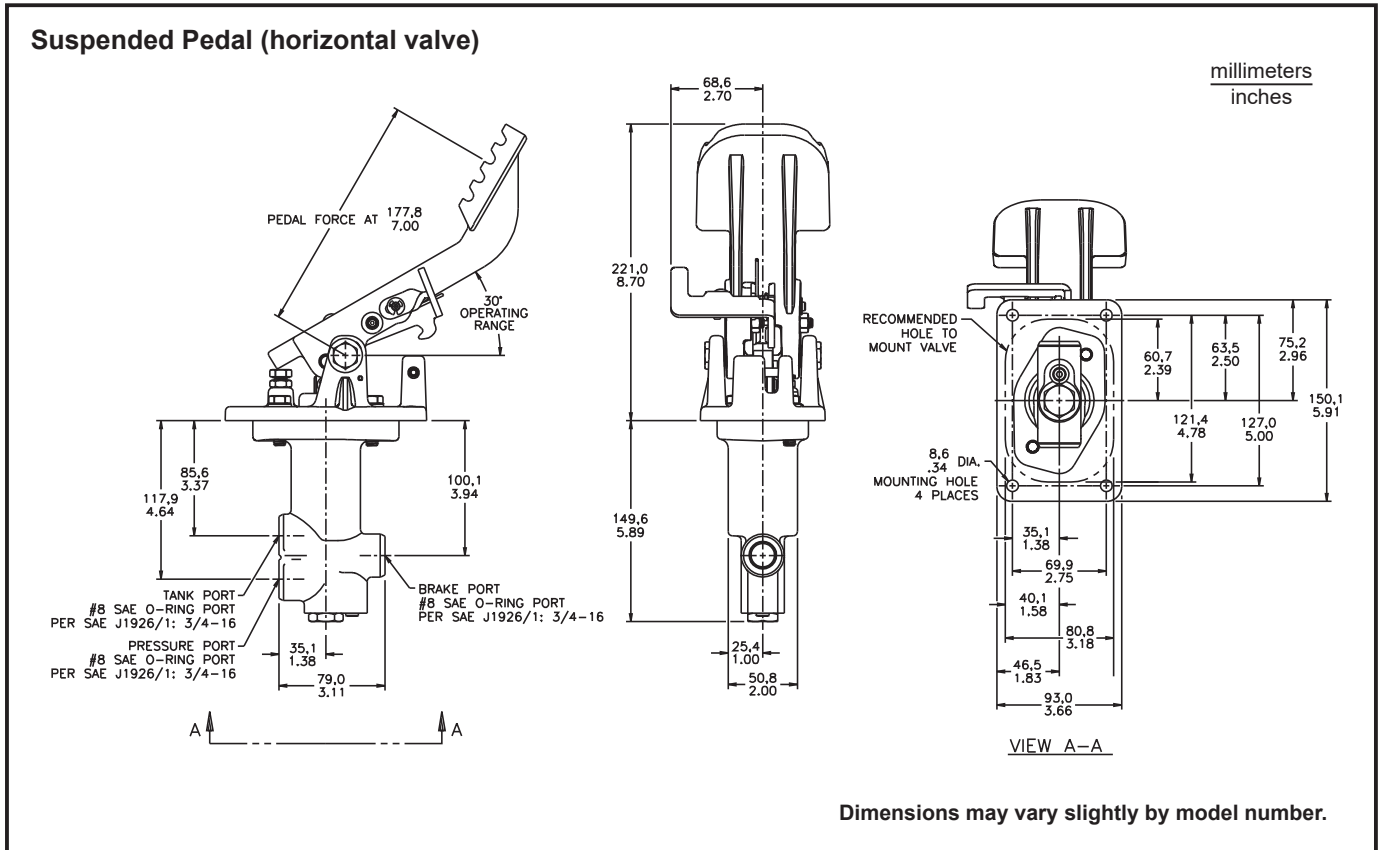

SPECIFICATIONS (no corresponding catalog code for these model numbers)

Model Number	Brake Pressure Setting		Approximate Pedal Force at Zero Pressure	
	bar	(PSI)	N	(lb)
03-460-408	22.1 ± 1.4	(320 ± 20)	231.3	(52)
03-460-416	22.1 ± 1.4	(320 ± 20)	231.3	(52)
* 03-460-418	24.8 ± 1.4	(360 ± 20)	231.3	(52)
03-460-440	103.4 ± 3.5	(1500 ± 50)	249.1	(56)
03-460-443	22.1 ± 1.4	(320 ± 20)	231.3	(52)
* 03-460-446	137.9 ± 6.9	(2000 ± 100)	231.3	(56)
* 03-460-447	151.7 ± 5.2	(2200 ± 75)	249.1	(56)
* 03-460-452	110.3 ± 3.5	(1600 ± 50)	231.3	(52)

* Pedal has no latch.

Brake pressure setting range all models 20.7 bar (300 PSI) to 206.8 bar (3000 PSI) in standard 3.5 bar (50 PSI) increments

Maximum input pressure all models 206.8 bar (3000 PSI)

Consult ZF Off-Highway Solutions Minnesota Inc. Applications Department for other available models and application detail.

(poppet design)

Reverse Modulating Valves

DESCRIPTION

These Reverse Modulating Valves can be used in negative braking systems to actuate a spring apply/hydraulic release service brake. The term "reverse modulation" is used because pressure is decreased to actuate the brake from a preset pressure that keeps the brake fully released. The preset pressure is regulated at a level above the full release pressure of the brake and must be maintained to assure that brake drag does not occur.

To actuate the spring apply/hydraulic release brake, apply the brake pedal and hydraulic pressure in the brake system is reduced causing the springs to apply the brake. Brake pedal position and force is proportional to the brake system pressure and provides the feedback necessary for good braking control.

Models are available with a latched pedal design for use in parking and/or dynamic braking.

FEATURES

- Poppet design provides for virtually zero leakage
- High capacity fluid displacement
- Oil immersed spring cavity protects return springs from outside contaminants

Typical Circuit Schematic

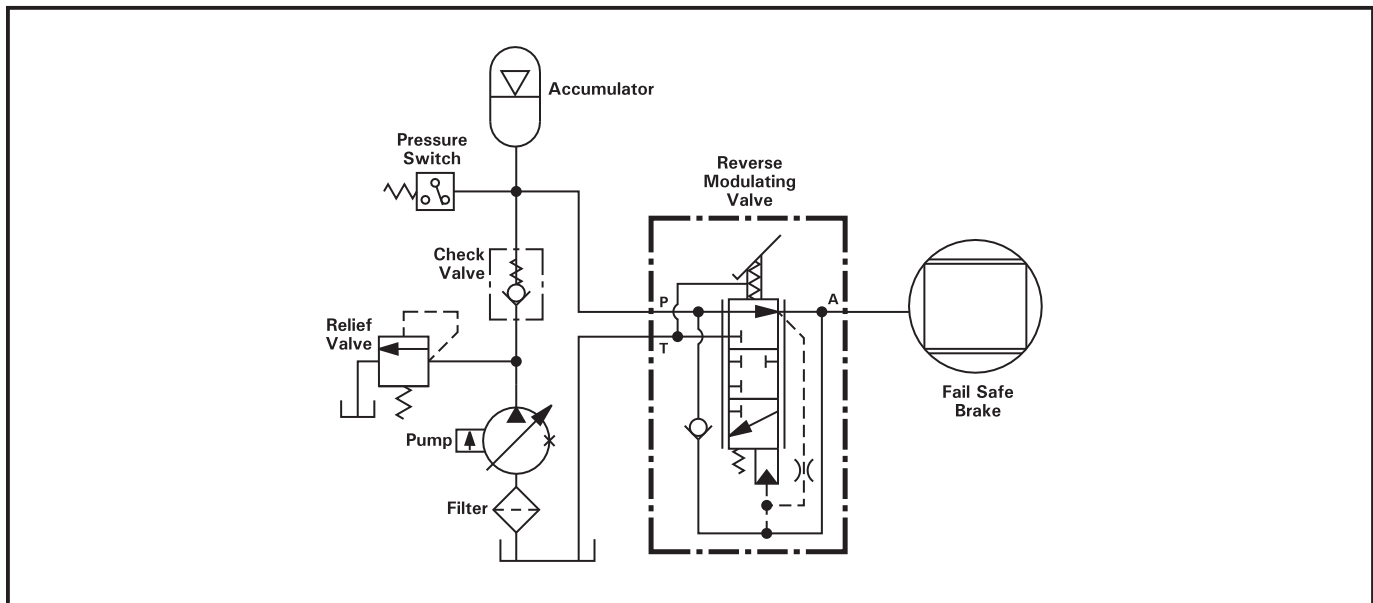

Pull Actuated (reverse modulating)



Typical Brake Valve

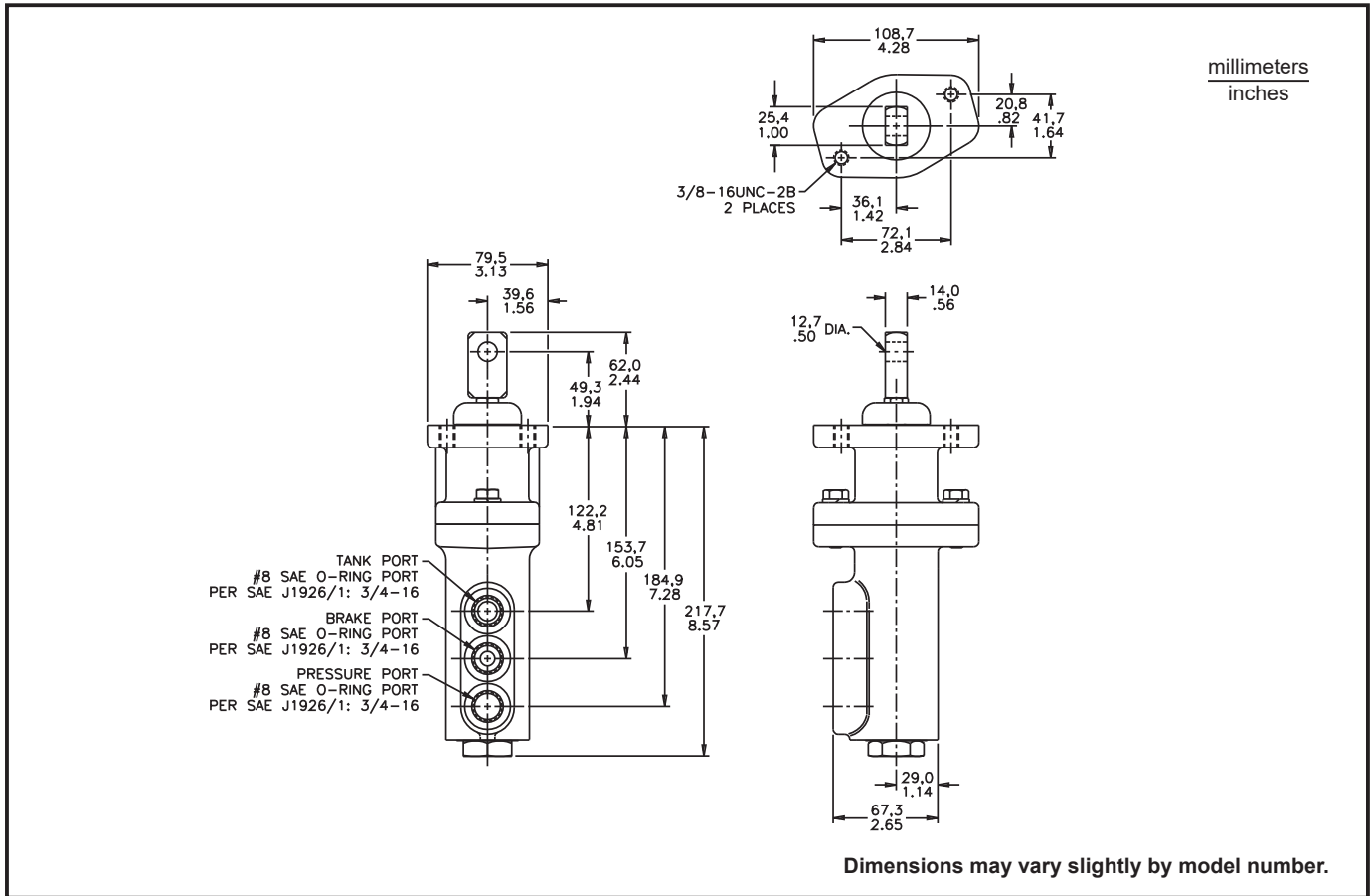

SPECIFICATIONS (no corresponding catalog code for these model numbers)

Model Number	Brake Pressure Setting		Approximate Pull Force at Zero Pressure		Maximum Pull Travel	
	bar	(PSI)	N	(lb)	mm	(inch)
20-100-320	69.0 ± 3.5	(1000 ± 50)	4225.0	(950)	7.62	(0.30)
20-100-420	13.8 ± 1.4	(200 ± 20)	4225.0	(950)	7.62	(0.30)
20-100-645	117.2 ± 3.5	(1700 ± 50)	4225.0	(950)	7.62	(0.30)
20-100-858	120.7 ± 1.7	(1750 ± 25)	4225.0	(950)	7.62	(0.30)
20-100-997	150.0 ± 6.9	(2175 ± 100)	3380.6	(760)	7.62	(0.30)
20-200-007	137.9 ± 6.9	(2000 ± 100)	2001.7	(450)	7.62	(0.30)

Brake pressure setting range all models 20.7 bar (300 PSI) to 206.8 bar (3000 PSI) in standard 3.5 bar (50 PSI) increments
 Maximum input pressure all models 206.8 bar (3000 PSI)

Consult ZF Off-Highway Solutions Minnesota Inc. Applications Department for other available models and application detail.

Pedal Actuated (reverse modulating)



Typical Brake Valve

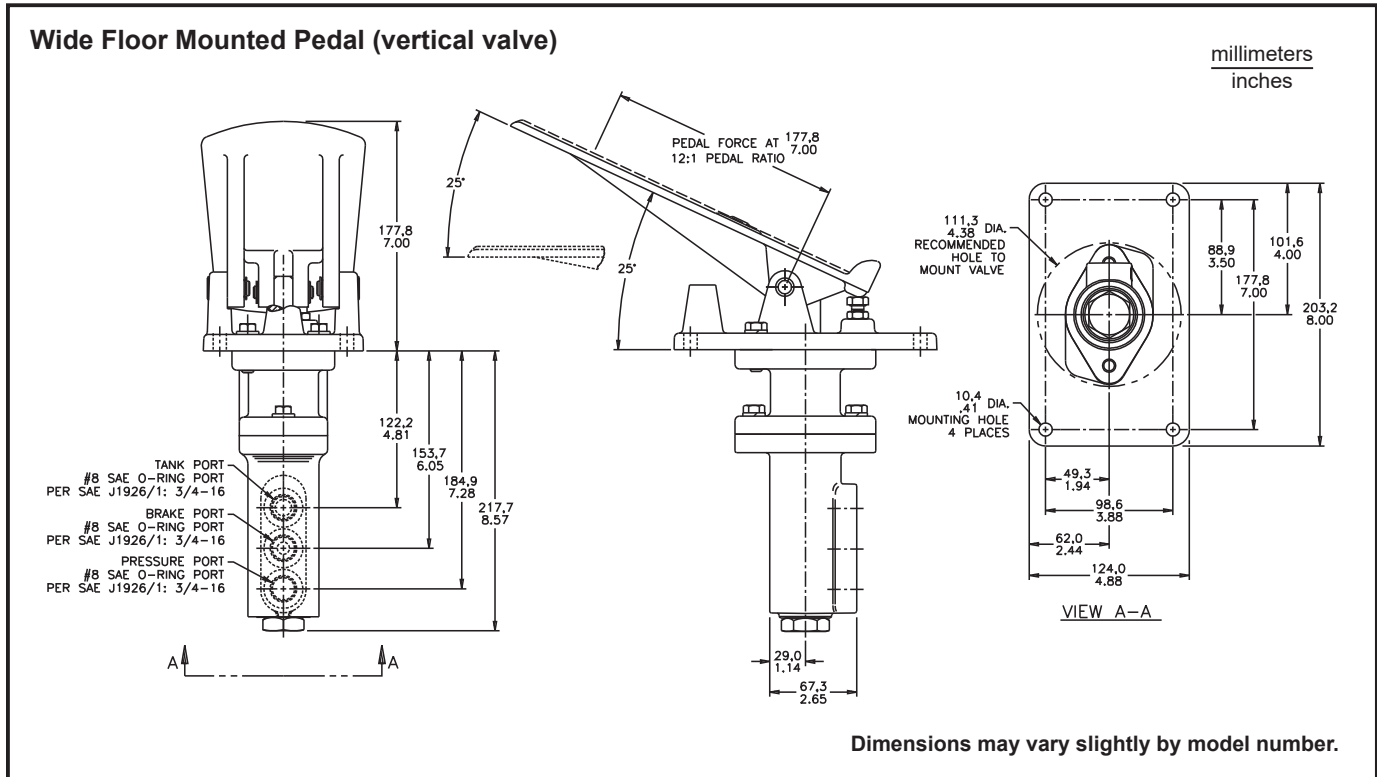

SPECIFICATIONS (no corresponding catalog code for these model numbers)

Model Number	Brake Pressure Setting		Approximate Pedal Force at Zero Pressure	
	bar	(PSI)	N	(lb)
03-460-300	103.4 ± 6.9	(1500 ± 100)	324.7	(73)
03-460-302	103.4 ± 1.7	(1500 ± 25)	244.7	(55)
03-460-304	117.2 ± 3.5	(1700 ± 50)	320.3	(72)
03-460-310	20.7 ± 0.7	(300 ± 10)	311.4	(70)
03-460-312	27.6 ± 0.7	(400 ± 10)	280.2	(63)
03-460-314	13.0 ± 0.8	(188 ± 12)	209.1	(47)
03-460-316	124.1 ± 3.5	(1800 ± 50)	320.3	(72)
03-460-318	141.4 ± 5.2	(600 ± 75)	320.3	(72)
03-460-324	106.9 ± 3.5	(1550 ± 50)	324.7	(73)
03-460-328	106.9 ± 3.5	(1550 ± 50)	244.7	(55)
03-460-362	124.1 ± 3.5	(1800 ± 50)	320.3	(72)
03-460-366	131.0 ± 6.9	(1900 ± 100)	422.6	(95)

Brake pressure setting range all models 20.7 bar (300 PSI) to 206.8 bar (3000 PSI) in standard 3.5 bar (50 PSI) increments

Maximum input pressure all models 206.8 bar (3000 PSI)

Consult ZF Off-Highway Solutions Minnesota Inc. Applications Department for other available models and application detail.

Pedal Actuated (reverse modulating)



Typical Brake Valve

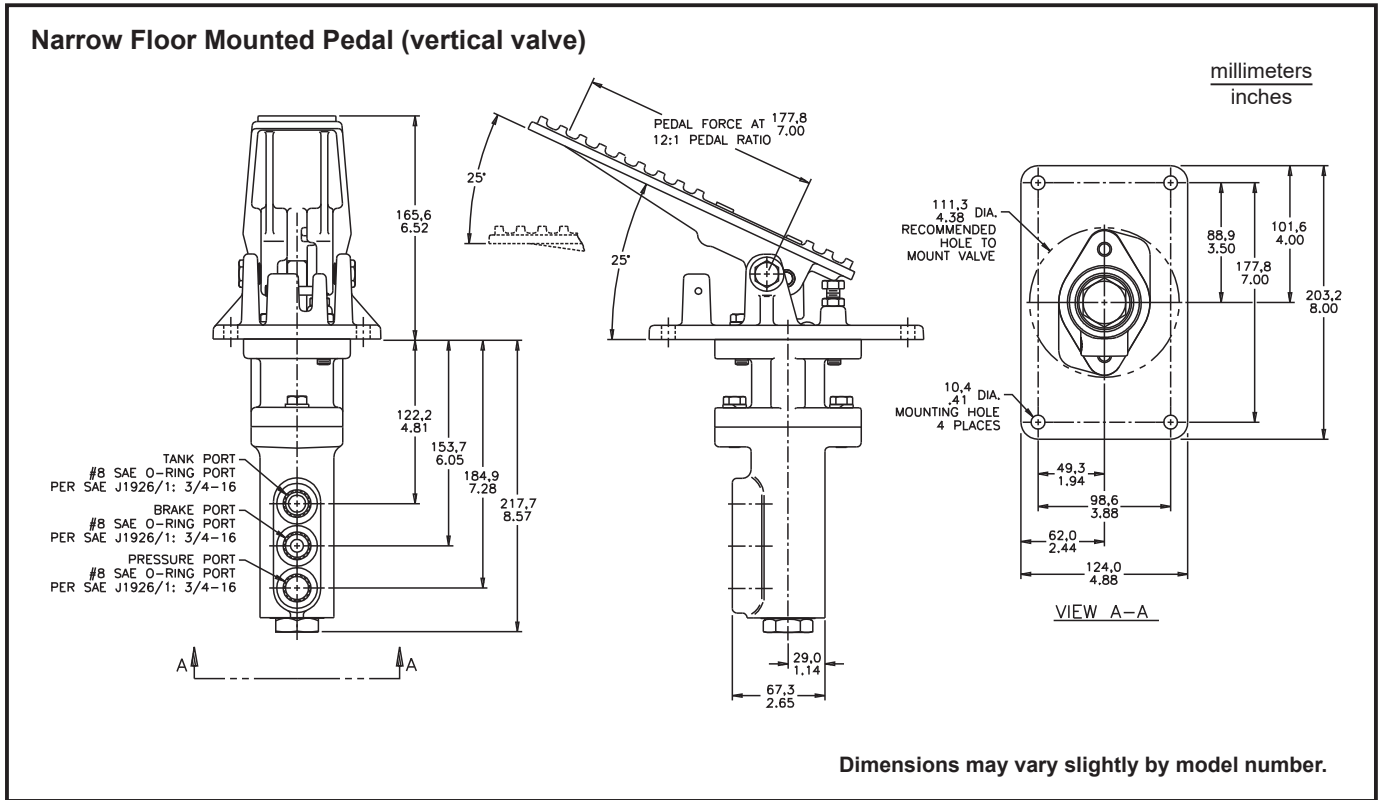

SPECIFICATIONS (no corresponding catalog code for these model numbers)

Model Number	Brake Pressure Setting		Approximate Pedal Force at Zero Pressure	
	bar	(PSI)	N	(lb)
03-460-308	117.2 ± 3.5	(1700 ± 50)	244.7	(55)
03-460-322	20.7 ± 1.7	(300 ± 25)	200.2	(45)
03-460-326	103.4 ± 3.5	(1500 ± 50)	244.7	(55)
03-460-357	103.4 ± 3.5	(1500 ± 50)	244.7	(55)
03-460-368	110.3 ± 3.5	(1600 ± 50)	209.1	(47)

Brake pressure setting range all models 20.7 bar (300 PSI) to 206.8 bar (3000 PSI) in standard 3.5 bar (50 PSI) increments
 Maximum input pressure all models 206.8 bar (3000 PSI)

Consult ZF Off-Highway Solutions Minnesota Inc. Applications Department for other available models and application detail.

Relay Valves



DESCRIPTION

ZF Off-Highway Relay Valves are a closed center design used for modulating output pressures up to 207 bar (3000 PSI). They can be adapted into a variety of hydraulic systems and are used in circuits where the brake control valve is too far from the brake to efficiently provide required fluid volume. These relay valves use pilot pressure from a remote brake valve to control modulated brake pressure.

FEATURES

- Compact size for use in restricted spaces
- Spool design provides smooth modulation at all pressures
- Power-off braking through limited stored energy in the accumulator(s)

Typical Circuit Schematic

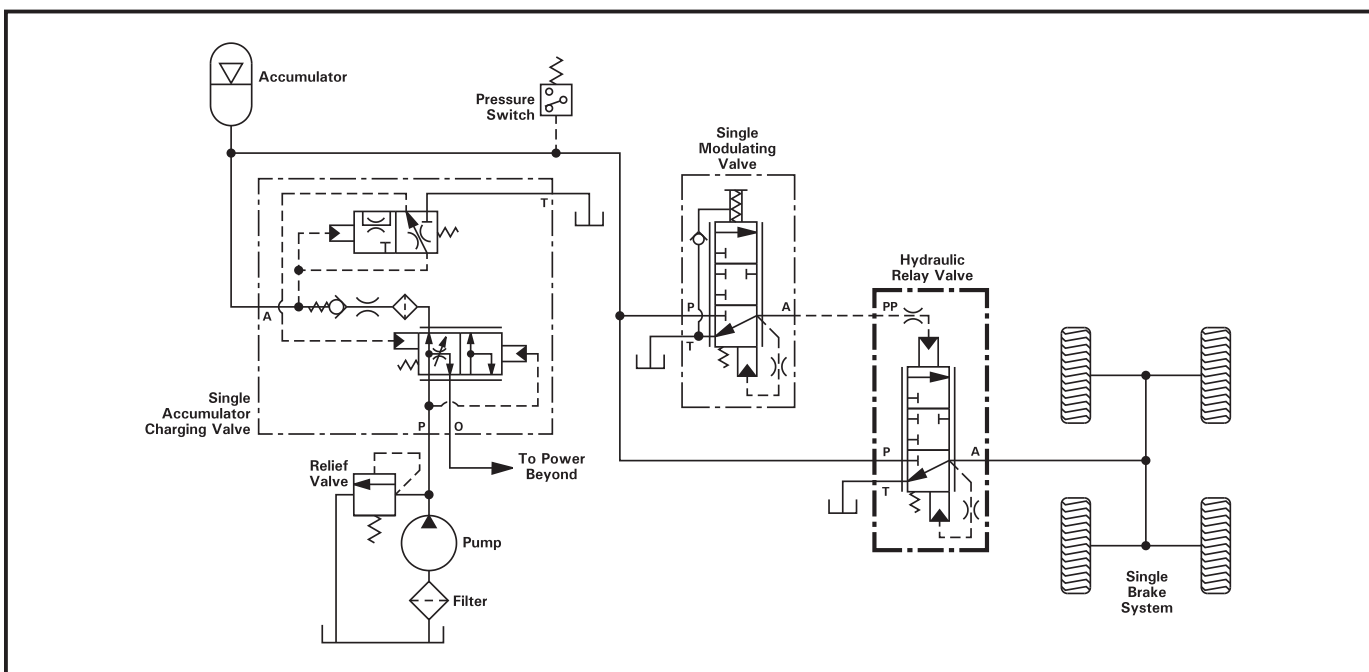

Typical Brake Valve

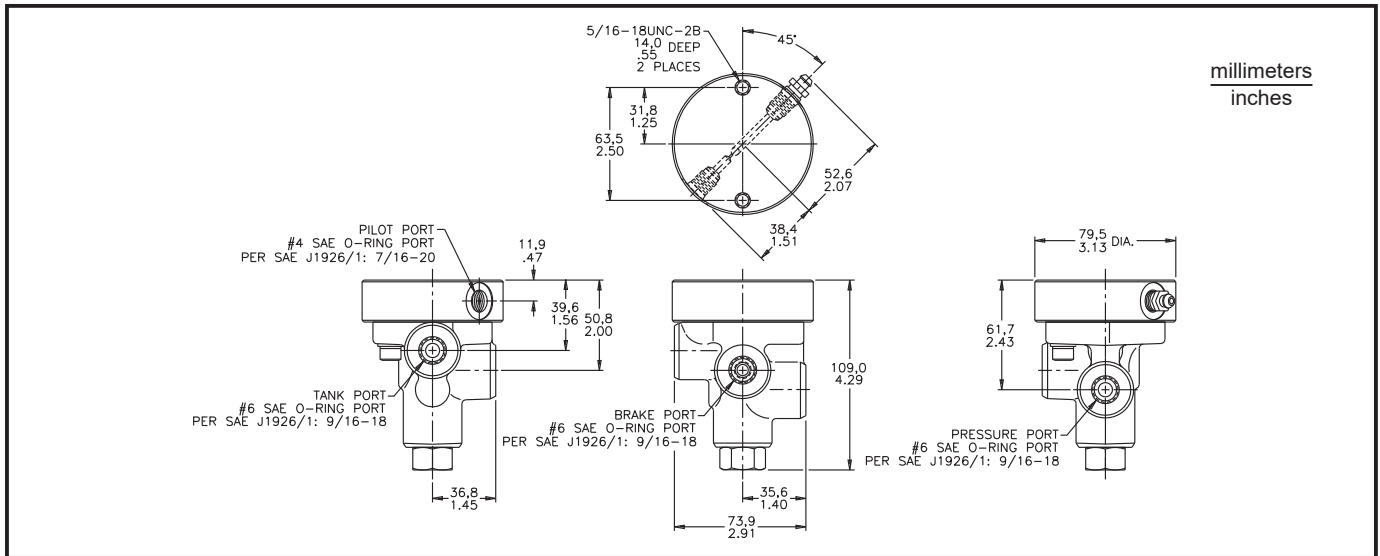

SPECIFICATIONS (no corresponding catalog code for this model number)

Model Number	* Inlet Port Pilot Pressure		Outlet Port Pressure	
	bar	(PSI)	bar	(PSI)
06-466-968	69.0	(1000)	65.9	(956)

* Pressure required to produce outlet pressure

Brake pressure setting range all models 20.7 bar (300 PSI) to 206.8 bar (3000 PSI) in standard 3.5 bar (50 PSI) increments
 Maximum input pressure all models 206.8 bar (3000 PSI)

Consult ZF Off-Highway Solutions Minnesota Inc. Applications Department for other available models and application detail.

Typical Brake Valve

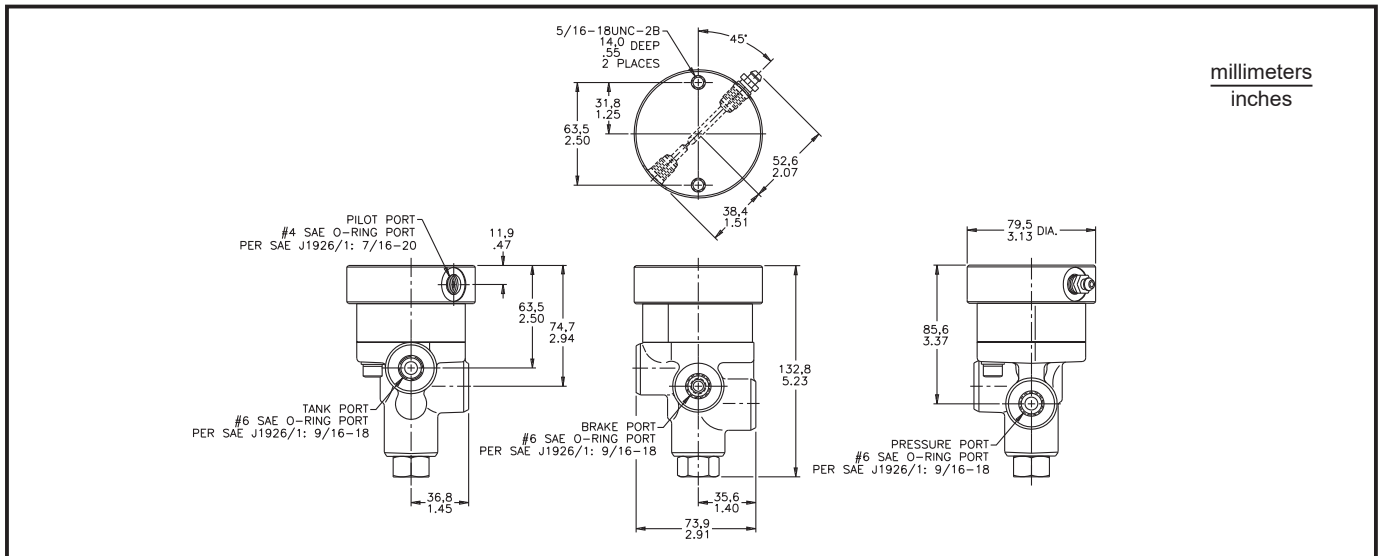

SPECIFICATIONS (no corresponding catalog code for this model number)

Model Number	* Inlet Port Pilot Pressure		Outlet Port Pressure	
	bar	(PSI)	bar	(PSI)
06-466-978	86.2	(1250)	131.0 ± 3.5	(1900 ± 50)

* Pressure required to product outlet pressure

Brake pressure setting range all models 20.7 bar (300 PSI) to 206.8 bar (3000 PSI) in standard 3.5 bar (50 PSI) increments
 Maximum input pressure all models 206.8 bar (3000 PSI)

Consult ZF Off-Highway Solutions Minnesota Inc. Applications Department for other available models and application detail.

Hystat Brake Valves



DESCRIPTION

The ZF Off-Highway Hystat Brake Valve was developed to destroke a hydrostatic transmission and then apply the vehicle brakes. This function is normally described as inching. When the valve is released, the brakes release and the hydrostatic transmission re-engages. This valve is application specific and must be carefully sized, contact ZF Off-Highway Solutions Minnesota Inc.

FEATURES

- Compact size for use in restricted spaces
- Spool design provides smooth modulation at all pressures
- Oil immersed spring cavity protects return springs from outside contaminants

Typical Circuit Schematic

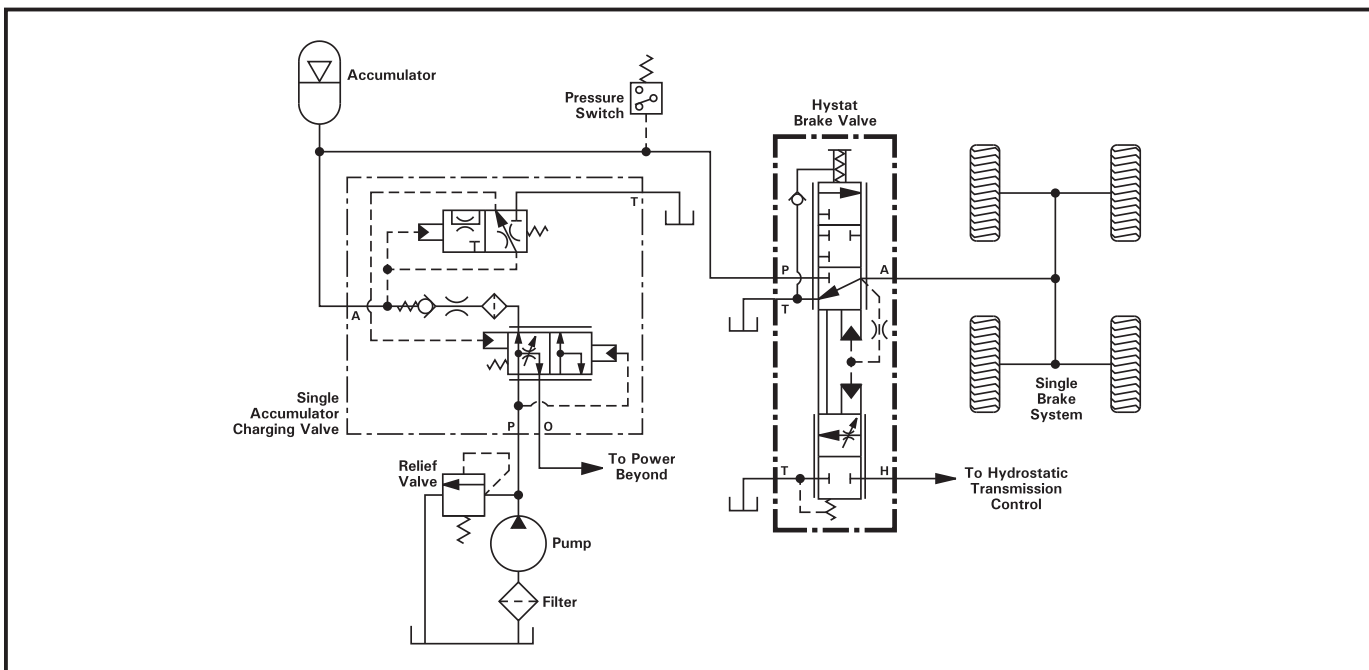

Typical Brake Valve

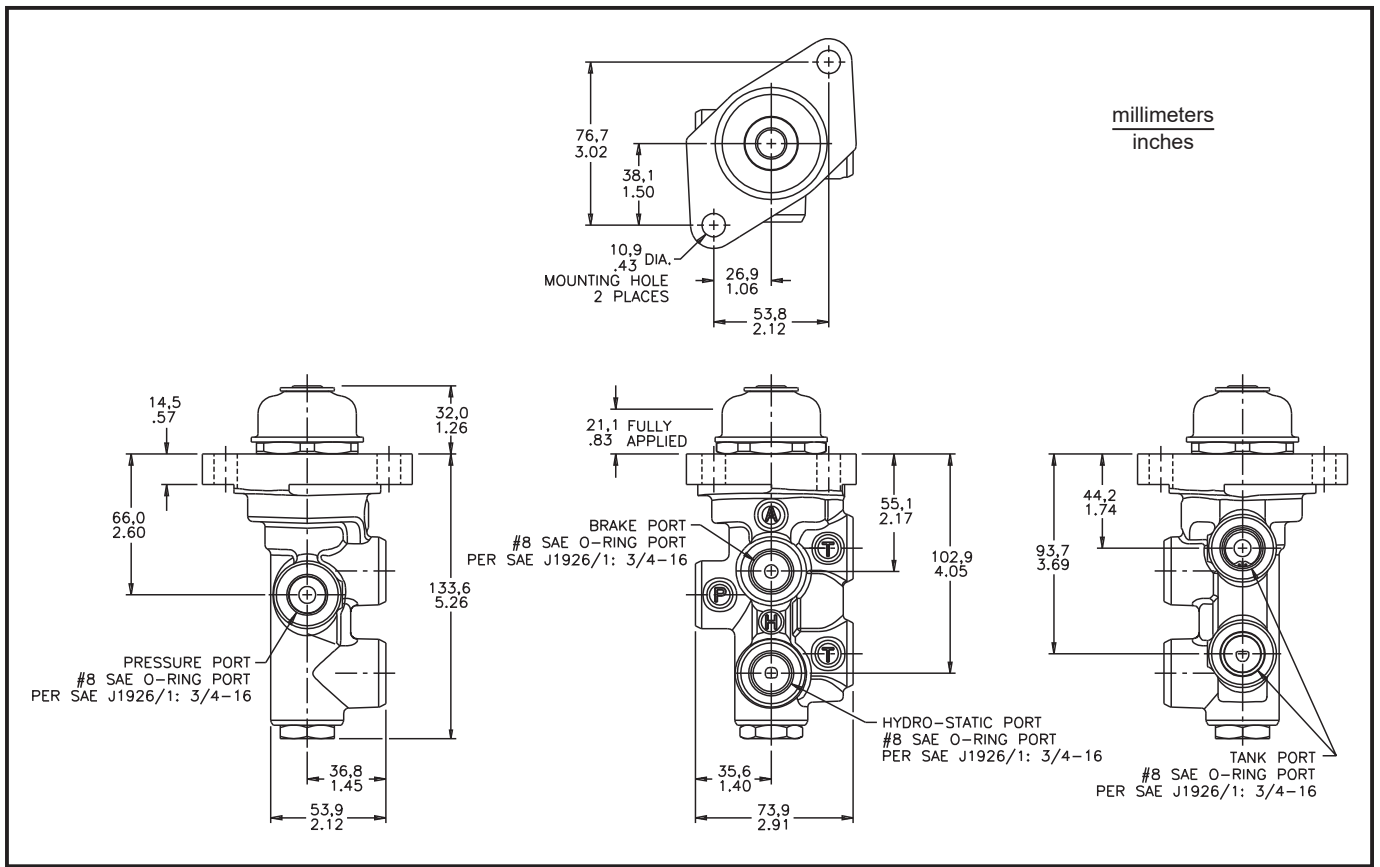

SPECIFICATIONS

Brake pressure setting range all models 20.7 bar (300 PSI) to 206.8 bar (3000 PSI) in standard 3.5 bar (50 PSI) increments
 Maximum input pressure all models 206.8 bar (3000 PSI)

Consult ZF Off-Highway Solutions Minnesota Inc. Applications Department for other available models and application detail.

Park Brake Valves with Auto Apply



PRINCIPLES OF OPERATION

The Park Brake Valve with Auto Apply provides added safety for vehicle and operator by controlling the actuation of the spring apply, hydraulic release park brake. Actuation is controlled either manually or by the emergency auto apply section of the valve. Manual control can be performed with a cable-lever arrangement or a hand grip knob for push-release/pull-apply operation.

The auto apply section of the park brake valve senses accumulator and brake pressure and at a predetermined declining pressure will automatically apply the brake 100%. With the brake applied, the control shaft is automatically moved to the apply position. A low pressure warning switch should also be installed in the system to alert the operator before an emergency actuation.

Before moving the vehicle, system accumulator pressure must rise above the auto apply pressure setting. The control shaft must then be moved to the released position. The control shaft cannot physically be moved to the release position until sufficient pressure is reached in the system.

FEATURES

- Added safety for vehicle and operator
- Controls on/off function of spring apply/hydraulic release parking brake
- Detents in the brake-release and brake-apply positions
- Automatically applies parking brake in the event of pressure loss
- Helps prevent dragging and excessive parking brake wear
- Alternate version incorporates a secondary means of manual actuation which is typically linked to a panic bar actuator in underground mining applications

Typical Circuit Schematic

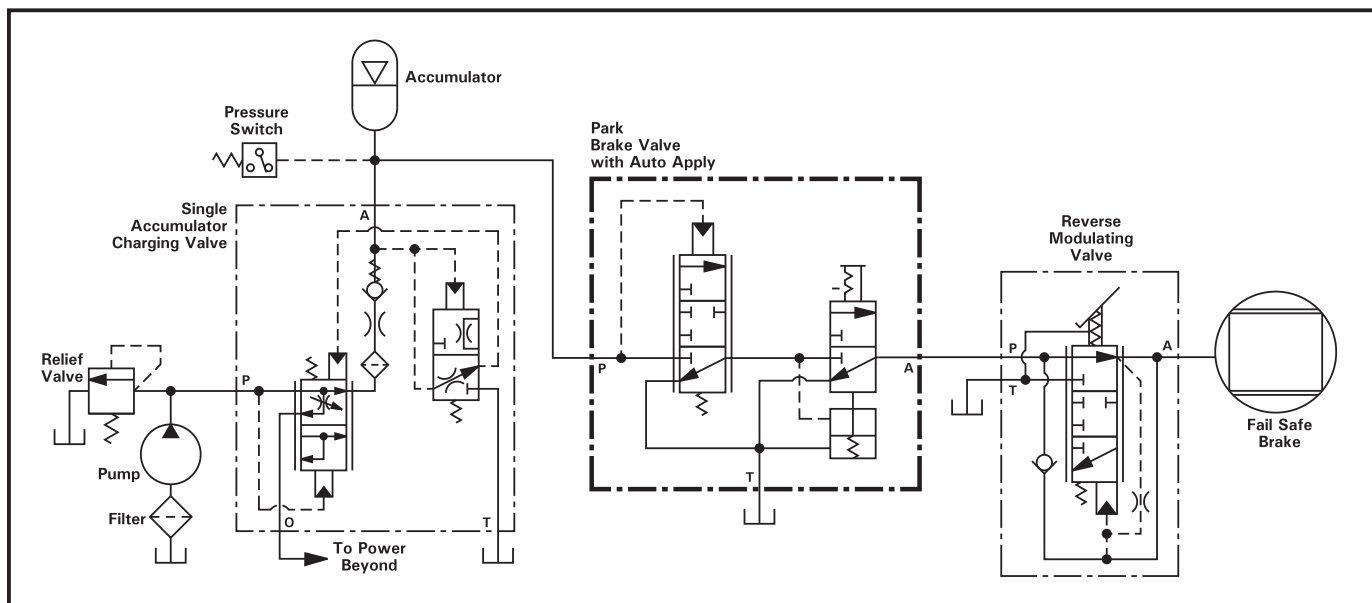

Typical Brake Valve

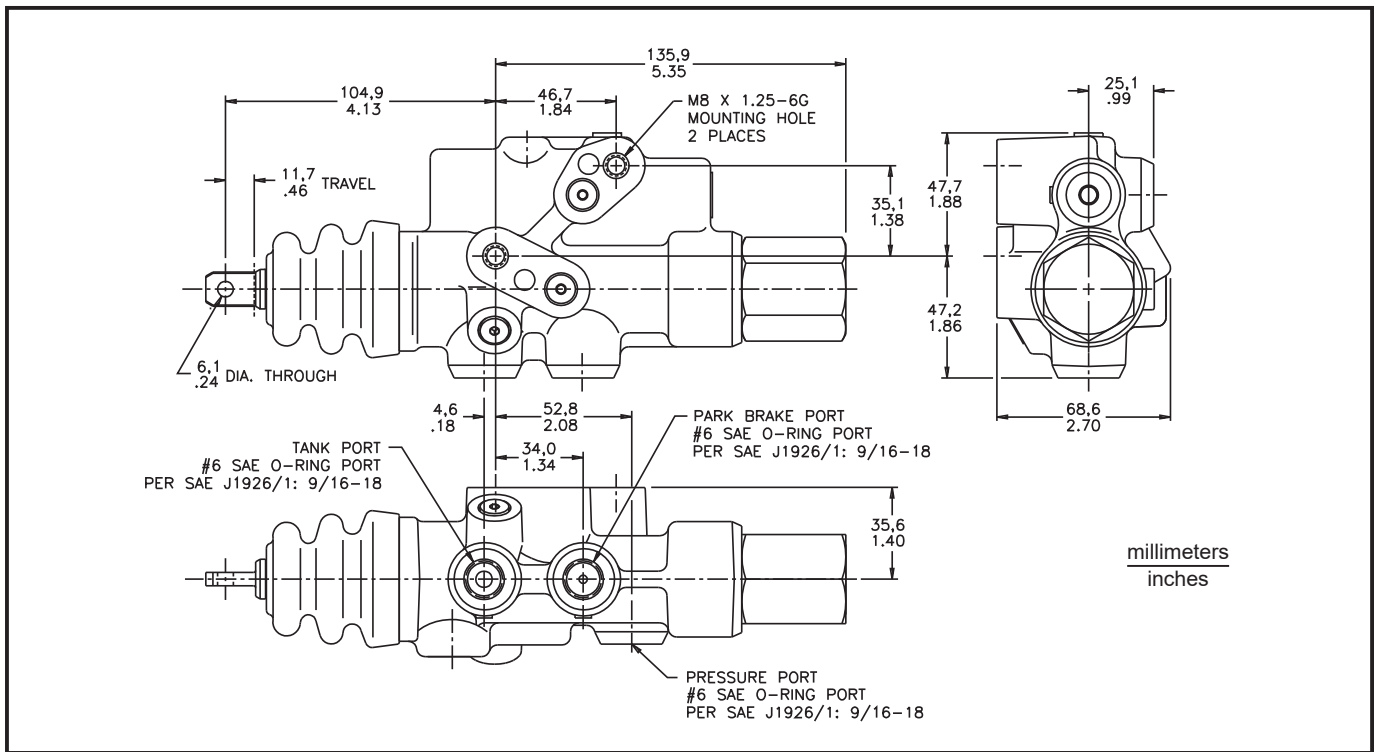

SPECIFICATIONS (no corresponding catalog code for this model number)

Model Number	Nominal Auto Apply Pressure	
	bar	(PSI)
06-464-936	37.9 ± 3.5	(550 ± 50)

Brake pressure setting range all models 20.7 bar (300 PSI) to 206.8 bar (3000 PSI) in standard 3.5 bar (50 PSI) increments
 Maximum input pressure all models 206.8 bar (3000 PSI)

Consult ZF Off-Highway Solutions Minnesota Inc. Applications Department for other available models and application detail.

Dual Power Brake Valve for Steering Assist



PRINCIPLES OF OPERATION

The Dual Power Brake Valve for Steering Assist is a closed center design used for modulating output pressures up to 137.9 bar (2000 PSI). This valve in conjunction with properly sized accumulators, provides normal and emergency power-off braking.

This unique integrated design can easily adapt to many dual pedal systems to provide steering assist power braking with one pedal applied or full power braking with both pedals applied giving equally balanced brake pressures.

The ZF Off-Highway Dual Power Brake Valve for Steering Assist can be adapted into a variety of hydraulic systems.

FEATURES

- Compact integrated design for use in restricted space
- Power off braking through limited stored energy in the accumulators
- Spool type construction provides smooth modulation at low pressures
- Direct acting spool provides a pedal feel accurately representing brake pressure
- One brake light switch port for monitoring individual or balanced brake pressure
- Auxiliary left and right side accumulator pressure switch ports
- Can be used on dual axle systems where balanced brake pressures are desired to each axle

Typical Circuit Schematic

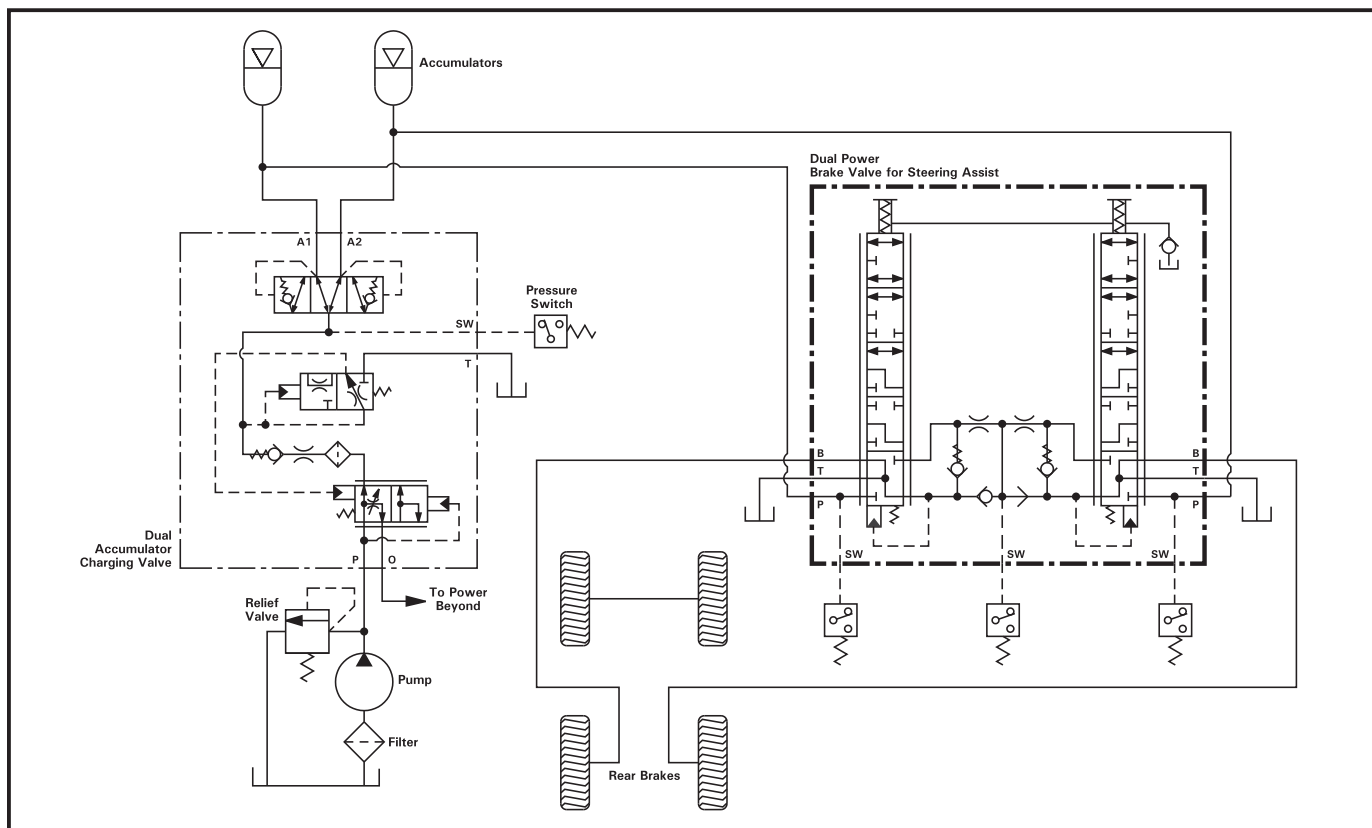

Typical Brake Valve

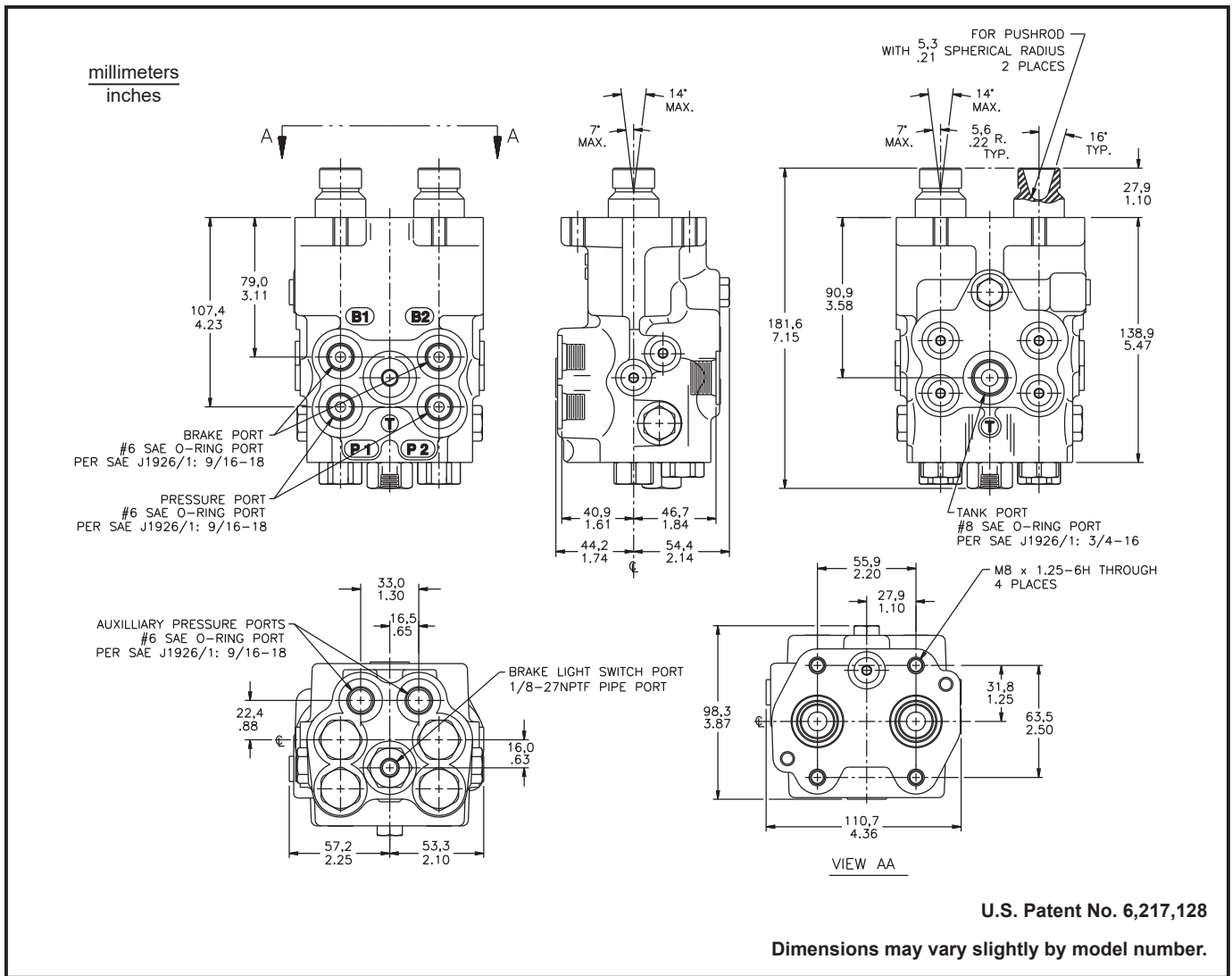

SPECIFICATIONS (no corresponding catalog code for these model numbers)

Model Number	Brake Pressure Setting		Push Rod Force at Pressure Setting (per side)		Approximate Push Rod Stroke	
	bar	(PSI)	N	(lb)	mm	(inch)
* 20-100-945	100.0 ± 3.5	(1450 ± 50)	1476.8	(332)	15.9	(0.625)

* Does not contain all switch ports, contact ZF Off-Highway Solutions Minnesota Inc.

Brake pressure setting range all models 20.7 bar (300 PSI) to 206.8 bar (3000 PSI) in standard 3.5 bar (50 PSI) increments

Maximum input pressure all models 206.8 bar (3000 PSI)

Consult ZF Off-Highway Solutions Minnesota Inc. Applications Department for other available models and application detail.

Linked Pedal Controls

(shown with tandem modulating valve)



PRINCIPLES OF OPERATION

The mechanically linked pedal controls are designed to integrate with ZF Off-Highway Modulating Valves.

The Linked Pedal Controls have an integral switch box, which is designed to include sensors and switches to control transmissions and illuminate brake lights.

This type of system is ideal for larger industrial equipment and earthmoving or construction equipment such as wheel loaders.

FEATURES

- Rigid pedal linkage construction
- Can be operated by either L or R pedal
- Both pedals operate in unison
- Provides independent braking to front and rear brake systems from one valve
- Oil immersed spring cavity protects return springs from outside contaminants
- Spool design provides smooth modulation at all pressures
- Provides "pedal feel" proportional to brake system pressure
- Tank ports communicated internally allow for one or two return lines to tank.

Typical Circuit Schematic

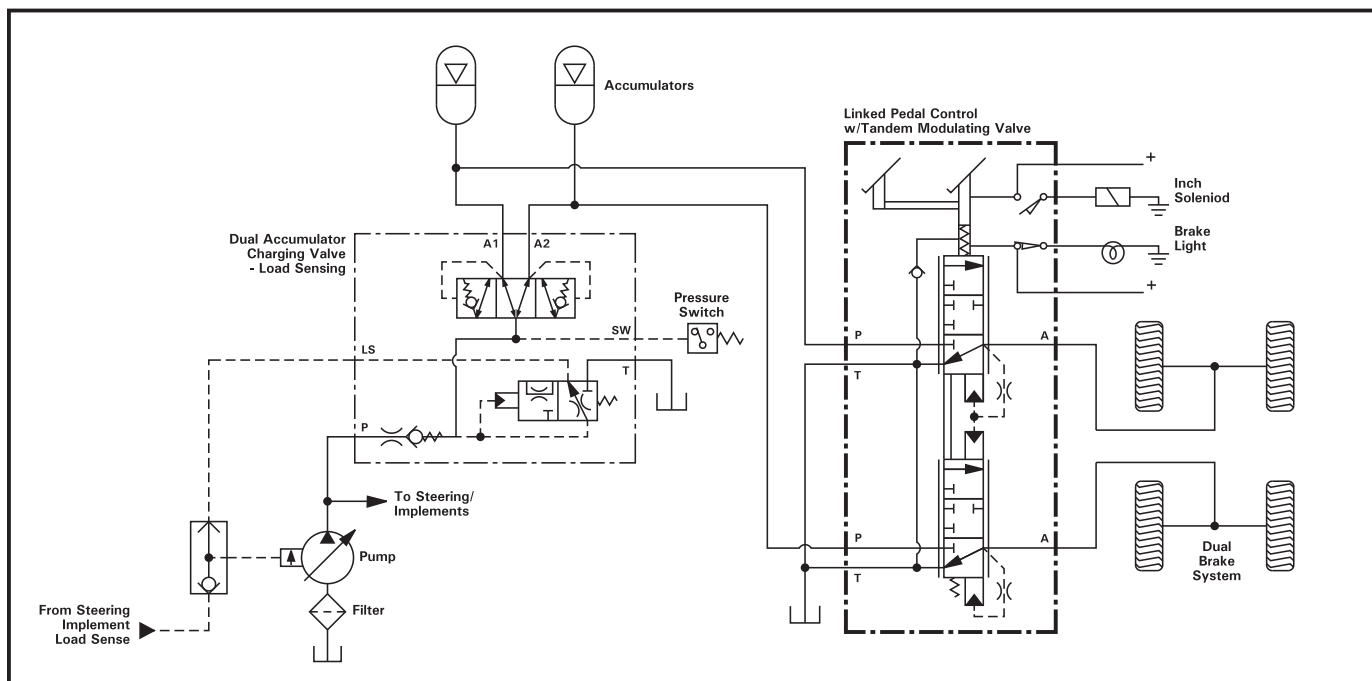

Typical Brake Valve

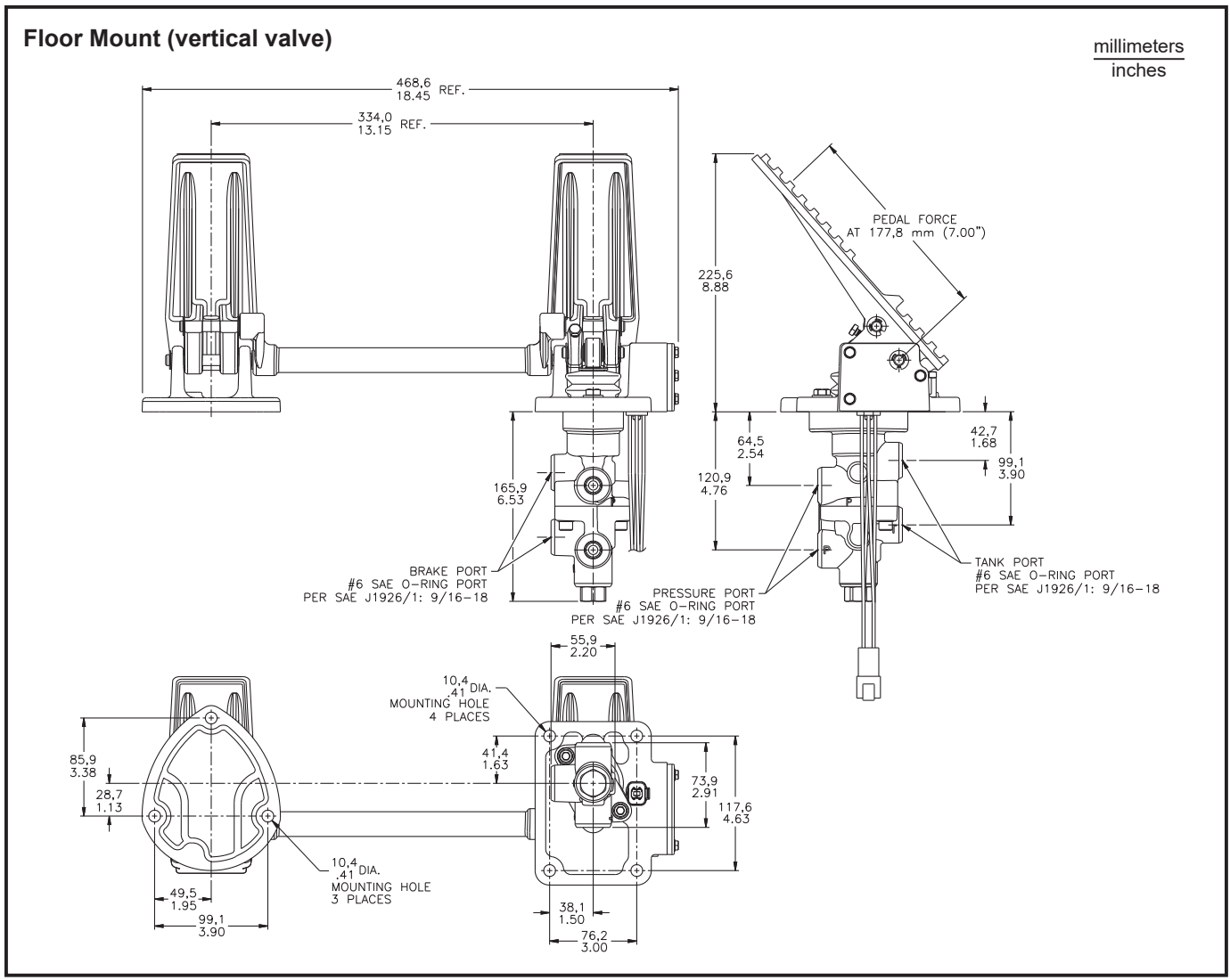

SPECIFICATIONS

Brake pressure setting range all models 20.7 bar (300 PSI) to 206.8 bar (3000 PSI) in standard 3.5 bar (50 PSI) increments
 Maximum input pressure all models 206.8 bar (3000 PSI)
Consult ZF Off-Highway Solutions Minnesota Inc. Applications Department for other available models and application detail.

USEFUL FORMULAS

$$\text{Piston Area (in}^2\text{)} = \pi (3.1416) \times r^2 \text{ (in)}$$

$$\text{Piston Radius (in)} = \sqrt{\frac{\text{Area (in}^2\text{)}}{\pi (3.1416)}}$$

$$\text{Force (lb)} = \text{Piston Area (in}^2\text{)} \times \text{Line Pressure (PSI)}$$

$$\text{Piston Area (in}^2\text{)} = \frac{\text{Force (lb)}}{\text{Line Pressure (PSI)}}$$

$$\text{Line Pressure (PSI)} = \frac{\text{Force (lb)}}{\text{Piston Area (in}^2\text{)}}$$

$$\text{Volume (in}^3\text{)} = \text{Piston Area (in}^2\text{)} \times \text{Stroke (in)}$$

$$\text{Piston Area (in}^2\text{)} = \frac{\text{Volume (in}^3\text{)}}{\text{Stroke (in)}}$$

$$\text{Stroke (in)} = \frac{\text{Volume (in}^3\text{)}}{\text{Piston Area (in}^2\text{)}}$$

$$\text{Volume (gallons)} = \text{Flow Rate (GPM)} \times \text{Time (min)}$$

$$\text{Flow Rate (GPM)} = \frac{\text{Volume (gallons)}}{\text{Time (min)}}$$

$$\text{Time (minutes)} = \frac{\text{Volume (gallons)}}{\text{Flow Rate (GPM)}}$$

$$\text{Flow Rate (GPM)} = \frac{\text{Pump Displacement (cir*)} \times \text{Pump RPM}}{231**}$$

$$\text{Pump displacement (cir)} = \frac{\text{Flow Rate (GPM)} \times 231}{\text{Pump RPM}}$$

$$\text{Pump RPM} = \frac{\text{Flow Rate (GPM)} \times 231}{\text{Pump Displacement (cir)}}$$

$$\text{PTO/Pump RPM} = \text{PTO \% Engine Speed} \times \text{Engine RPM}$$

$$\text{PTO \% Engine Speed} = \frac{\text{PTO/Pump RPM}}{\text{Engine RPM}}$$

$$\text{Engine RPM} = \frac{\text{PTO/Pump RPM}}{\text{PTO \% Engine Speed}}$$

$$\text{Horsepower} = \frac{\text{Flow Rate (GPM)} \times \text{Line Pressure (PSI)}}{1714 \times \% \text{ Pump Efficiency}}$$

$$\text{Horsepower} = \frac{\text{Torque (lb}\cdot\text{ft)} \times \text{RPM}}{5252}$$

$$\text{Torque (lb}\cdot\text{ft)} = \frac{\text{Horsepower} \times 5252}{\text{RPM}}$$

$$\text{RPM} = \frac{\text{Horsepower} \times 5252}{\text{Torque (lb}\cdot\text{ft)}}$$

* cir = cubic inches per revolution

** 231 cubic inches = 1 U.S. gallon

NOTES

NOTES

About ZF Friedrichshafen AG

ZF is a global technology company supplying systems for passenger cars, commercial vehicles and industrial technology, enabling the next generation of mobility.

ZF allows vehicles to see, think and act. In the four technology domains of Vehicle Motion Control, Integrated Safety, Automated Driving, and Electric Mobility, ZF offers comprehensive product and software solutions for established vehicle manufacturers. Learn more at ZF.co

ZF Off-Highway Solutions Minnesota Inc.

1911 Lee Boulevard
North Mankato, MN U.S.A. 56003-2507
tel: +1 507 625 6426 fax: +1 507 625 3212

