



PRODUCT BULLETIN

Hydraulic Brake Locks Dual Cable Lock

DESCRIPTION

ZF Dual Cable Locks supplement a vehicle's standard parking brake by utilizing the hydraulic service brake system. Incorporating two manually operated one-way check valves in a single housing, dual cable locks hold fluid under pressure in the selected brakes. Dual cable locks can hold pressure in two separate fluid lines. They can provide 2-wheel locking on vehicles equipped with multi-channel anti-lock brake systems (ABS), or 4-wheel lock-up on dual brake systems or vehicles with single channel ABS. The lock is mounted in a remote location and operated by a cable and knob that is accessible on the dash.

Hydraulic brake locks are ideal for use on vehicles in the construction, mining, forestry, agriculture, and materials handling industries as well as on multi-stop delivery vehicle, and recreational vehicles.

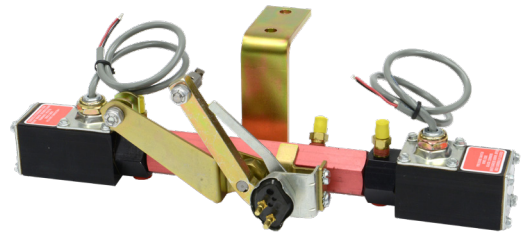

Typical Installations

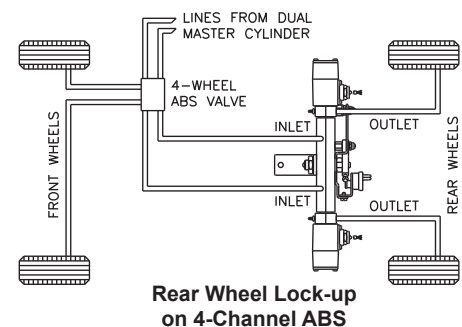
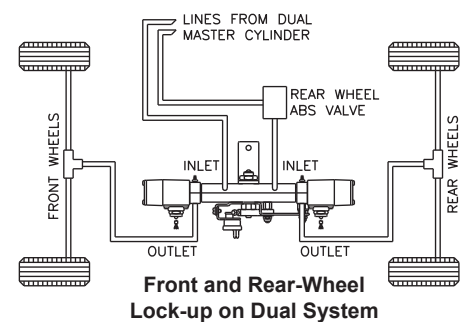

Front Wheel Lock-up on 3-channel ABS

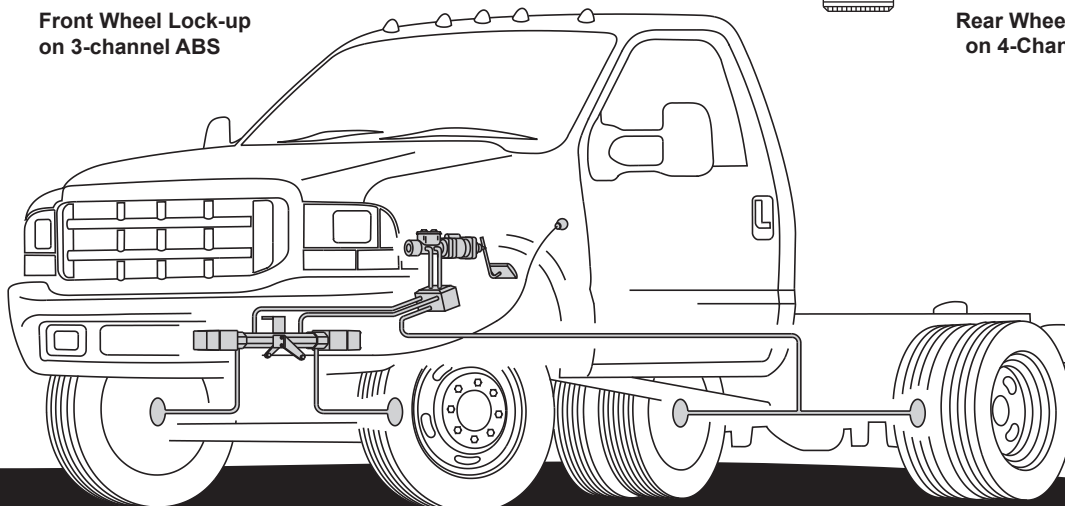

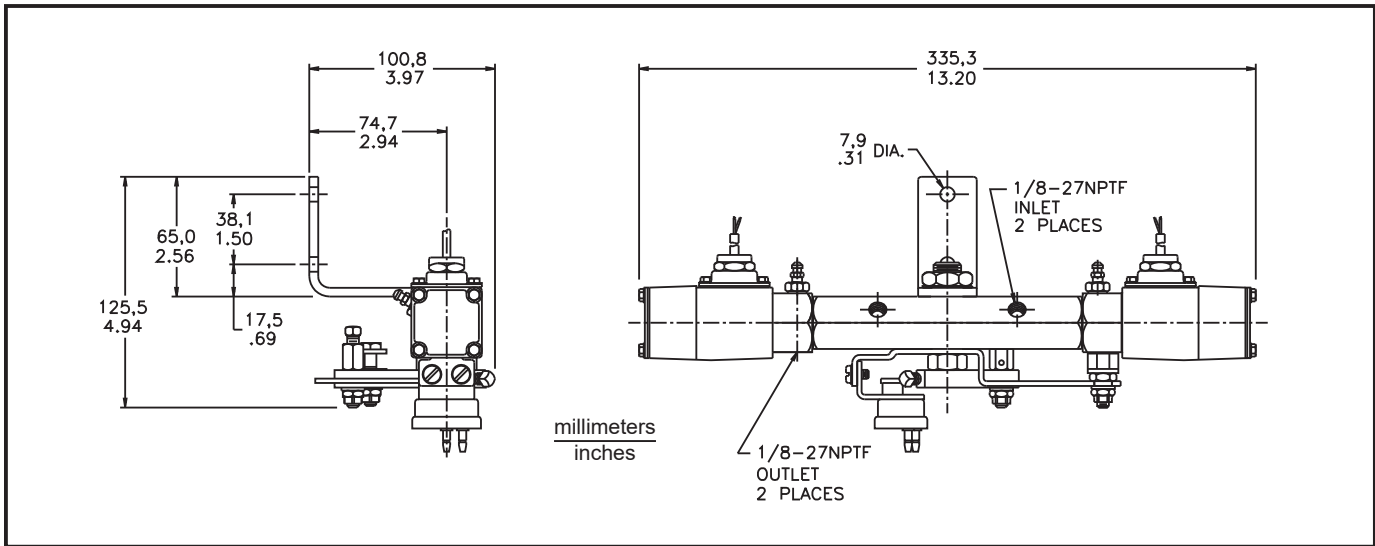

Dual Cable Lock Operation

To Lock: Set parking brake. Pull Dual Cable Lock knob/cable completely out. Apply service brakes firmly until alarm stops.

To Release: Push Dual Cable Lock knob/cable completely in. Release parking brake.

| Model Number | Description |
|-----------------|--|
| 02-640-169 (BF) | Dual Cable Lock - 3/16 and 1/4 inch fittings - includes 10 foot cable |
| 02-640-202 (HO) | Dual Cable Lock - 3/16 and 1/4 inch fittings - includes 10 foot cable |

BF = DOT 3, 4, 5 and 5.1 brake fluid
HO = mineral base hydraulic oil

Low Pressure Warning Switch

All hydraulic brake locks include a low pressure warning switch for your safety and the safety of others who may be exposed to danger if the vehicle moves.

The low pressure warning switch must be used in combination with an audible or visual alarm to signal a possible reduction in brake pressure and holding capability. **Do not disconnect the Low Pressure Switch.**

The low pressure warning switch provides two important safety features. First, a signal that indicates that sufficient pressure to hold the vehicle has been locked in the braking system. Second, if a loss of pressure occurs in the locked brake system, the alarm will activate indicating insufficient brake holding pressure.

Brake locks can be used in many different vehicle applications. Please contact ZF Off-Highway Solutions Minnesota Inc. for assistance in choosing a brake lock best suited for your application.

This publication is not subject to any update service. Information contained in this publication was in effect at the time the publication was approved for printing and is subject to change without notice or liability. ZF Off-Highway Solutions Minnesota Inc. reserves the right to revise the information presented or to discontinue the production of parts described at any time.



ZF Off-Highway Solutions Minnesota Inc.

1911 Lee Boulevard / North Mankato, MN U.S.A. 56003

Tel: +1 507 625 6426 **Fax:** +1 507 625 3212