

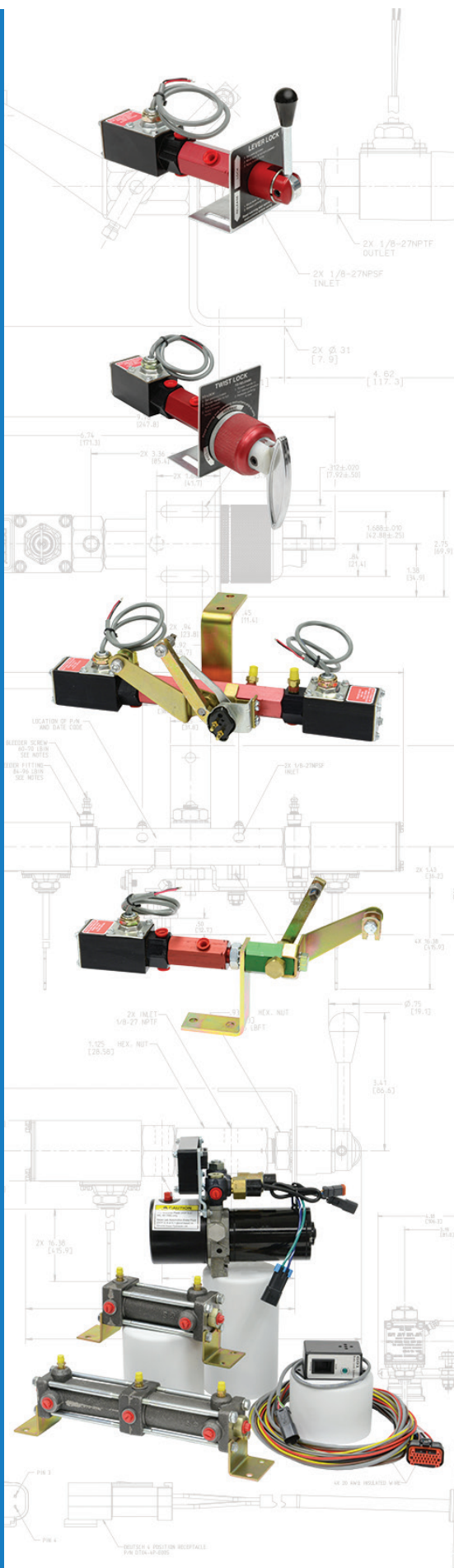

# BRAKE LOCK APPLICATION GUIDE



## 2023-2024

In addition to a well maintained and adjusted mechanical parking brake, experience has shown that in many uses, additional supplemental holding is necessary. This can be done in the form of wheel chocks, outriggers, or other means to keep all wheels that are in contact with the ground from moving.

ZF Hydraulic Brake Locks are ideal for use on vehicles with hydraulic brake systems. Typical uses are in the construction, mining, forestry, agriculture, material handling industries, multi-stop delivery vehicles, and recreational vehicles, such as motor homes and off-road 4-wheel drives.

All ZF Brake Locks are for supplemental brake holding and are to only be used in conjunction with a vehicle's properly functioning mechanical parking brake. The brake locks use the vehicle's service brakes as an operational supplement to the parking brakes and are not intended to be used as the primary parking brake or to be used for prolonged parking.

Several types of brake locks are available for use in single, dual, split, or anti-lock brake systems. The type of brake system on the vehicle will determine which brake locks can be used. If you have questions regarding the selection of the proper brake lock, contact ZF Off-Highway Solutions Minnesota Inc.

# BRAKE LOCK PRODUCT LINE



**USER INTERFACE**



**CONTROL MODULE**

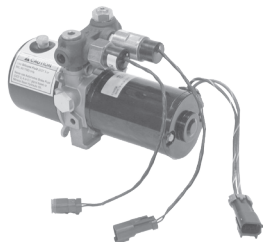

**POWER UNIT**

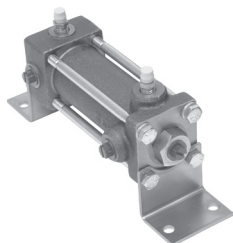

**SINGLE ACTUATOR**

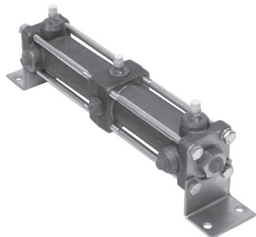

**DUAL ACTUATOR**



**WIRE HARNESS**

## 691 Brake Lock System

691 Brake Lock Systems lock hydraulic pressure in the service brakes to supplement the vehicle's original equipment parking brake and provide extra holding in heavy-duty and high frequency applications. These systems also function as an interlock to apply pressure to the service brakes when other vehicle mounted equipment is being used.

The 691 System consists of a small electrohydraulic pump, remote mounted actuator (single and/or dual), electronic control module, and a small dash mounted user interface. The operator simply activates a switch, and the 691 System automatically applies, monitors, and maintains brake-locking pressure.

A 691 Brake Lock will significantly enhance vehicle holding capability while not interfering with normal service brake function.

All ZF 691 Brake Lock Systems are for vehicles using Brake Fluid type braking systems.

### MODELS:

- 02-691-101** Single Brake Lock System  
(for vehicles over 19,000 GVM)
- 02-691-109** Single Brake Lock System  
(for vehicles under 19,000 GVM)
- 02-691-201** Dual Brake Lock System  
(for vehicles over 19,000 GVM)
- 02-691-209** Dual Brake Lock System  
(for vehicles under 19,000 GVM)
- 02-691-303** 3-Channel Anti-Lock Brake Lock System  
(for vehicles over 19,000 GVM)
- 02-691-305** 3-Channel Anti-Lock Brake Lock System  
(for vehicles under 19,000 GVM)
- 02-691-403** 4-Channel Anti-Lock Brake Lock System  
(for vehicles over 19,000 GVM optional on others)

**NOTE: 691 Power Unit uses silicone fluid.**  
**See page 14 for 691 Models and Sub-Components.**

# BRAKE LOCK PRODUCT LINE

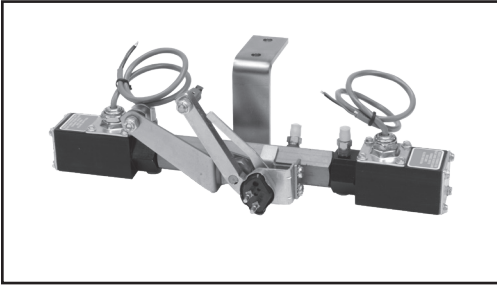

## Dual Cable Lock

Dual Cable Locks are cable operated and are designed to supplement a vehicle's original equipment parking brake by utilizing the hydraulic service brakes of a vehicle equipped with a dual or split braking system. Dual Cable Locks can provide 4-wheel lockup for hydraulic dual brake systems or rear wheel ABS, as well as 2-wheel lockup for hydraulic 3 and 4 channel ABS. Each Dual Cable Lock includes two low pressure warning switches.

### MODELS:

**02-640-169** Includes - 3/16 and 1/4 inch fittings, 10 ft. cable - (BF)

**02-640-202** Includes - 3/16 and 1/4 inch fittings, 10 ft. cable - (HO)

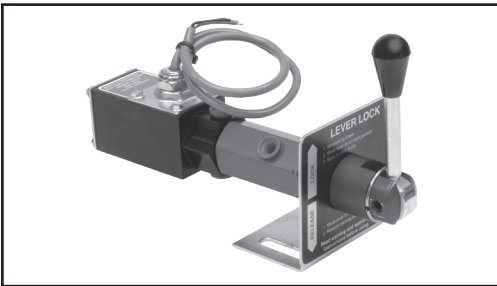

## Lever Lock

Lever Locks are designed to supplement a vehicle's original equipment parking brake by utilizing the hydraulic service brakes. Lever Locks are manually operated one-way check valves which lock fluid under pressure in the selected brakes. Hand operation leaves the operator's feet free for clutch and throttle pedal operation. Each Lever Lock includes a low pressure warning switch.

### MODELS:

**02-640-125** Includes - 3/16 and 1/4 inch fittings - (BF)

**02-640-126** Includes - 3/16 and 1/4 inch fittings - (HO)

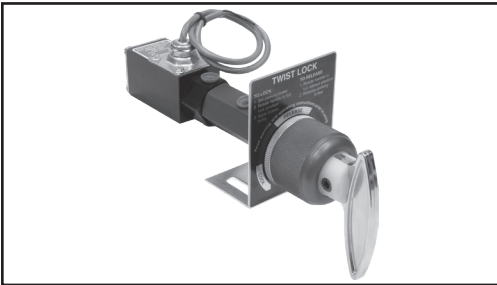

## Twist Lock

Twist Locks are functionally the same as lever locks. The differences being a Twist Lock has a rotary action handle and the push rod is sealed and lubricated with silicone grease for tough environmental applications. Each Twist Lock includes a low pressure warning switch.

### MODELS:

**03-640-075** Includes - 3/16 and 1/4 inch fittings - (BF)

**03-640-076** Includes - 3/16 and 1/4 inch fittings - (HO)

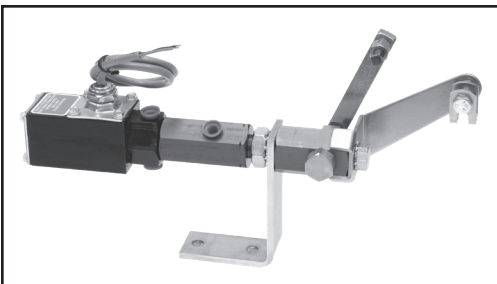

## Cable Lock

Cable Locks are functionally the same as lever locks and twist locks. The Cable Lock is for use in applications where there is limited space under the dash or in the cab. The lock is mounted in a remote location and operated by a cable and knob that is accessible to the operator. Each Cable Lock includes a low pressure warning switch.

### MODELS:

**02-640-023** Includes - 3/16 and 1/4 inch fittings, 10 ft. cable - (BF)

(BF) = Brake Fluid (HO) = Hydraulic Oil

# DIFFERENT BRAKE SYSTEMS

Typical hydraulic braking systems in use today vary depending on manufacturer and size of vehicle. For instance, a vehicle equipped with a single system may have a firewall mounted booster or possibly a frame mounted remote booster. The same holds true for the dual and split systems. The rear wheel anti-lock system is a dual brake system with an anti-lock valve installed.

All-wheel anti-lock systems are defined as 3-channel or 4-channel systems (check the number of outlet lines from the anti-lock control valve). To be absolutely sure with which braking system your vehicle is equipped, check it. Look for identifying features such as dual flex lines at rear axle or front wheels, number of master cylinder lines, anti-lock valve(s), etc. Then, compare with circuits shown here.

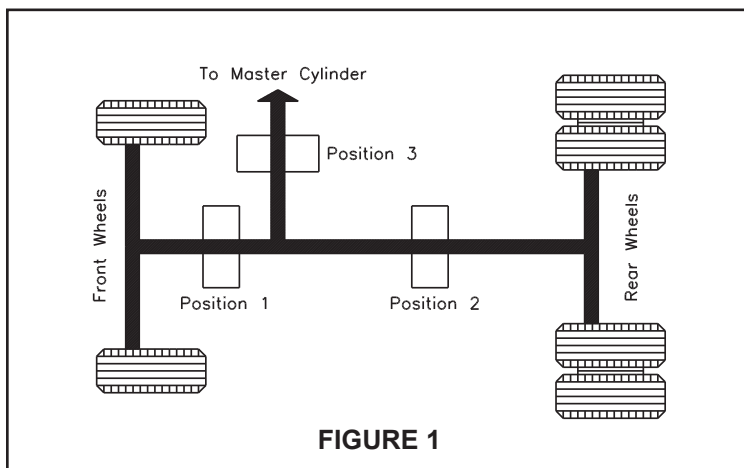

## TYPICAL SINGLE SYSTEM

One single hydraulic system serving both front and rear brakes.

**Identifying Feature:**

1. One line from master cylinder.

**Lock Position:**  
 (1) Front Axle      (2) Rear Axle      (3) 4-Wheel

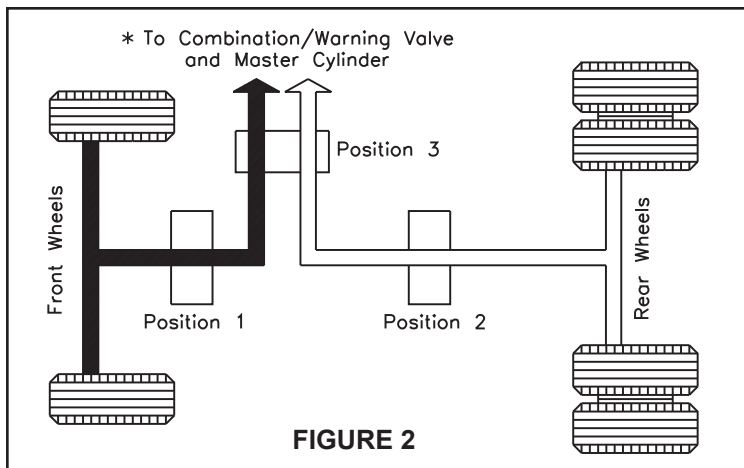

## TYPICAL DUAL SYSTEM (Vertical Split)

Two independent braking systems. One system leads to the front brakes and the other system to the rear brakes.

**Identifying Feature:**

1. Two lines from master cylinder.
2. Combination valve (used on some models).

**Lock Position:**  
 (1) Front Axle      (2) Rear Axle\*      (3) 4-Wheel

\*Some imported vehicles use two separate air boosted master cylinders.

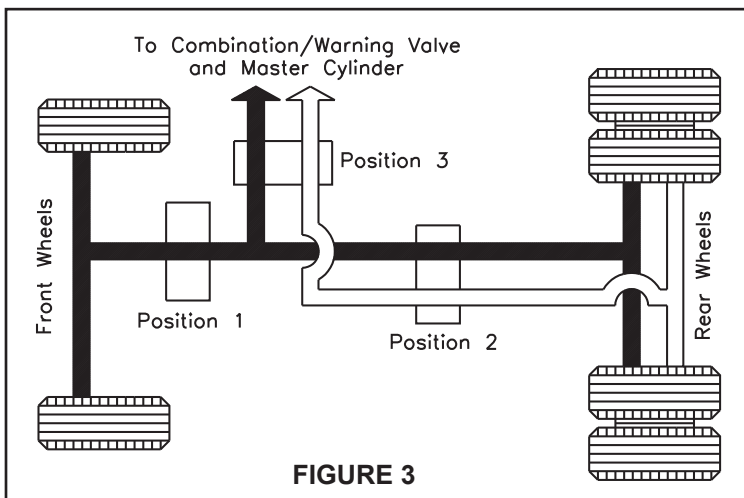

## TYPICAL SPLIT SYSTEM (1 1/2 x 1/2)

Two independent braking systems. One system leads to the front and the rear brakes and the other system leads only to the rear brakes.

**Identifying Feature:**

1. Two lines from master cylinder.
2. Single hose to each front wheel.
3. Two hoses to rear axle.

**Lock Position:**  
 (1) Front Axle      (2) Rear Axle      (3) 4-Wheel

**CAUTION: For position 2 or 3, both halves of system must be locked.**

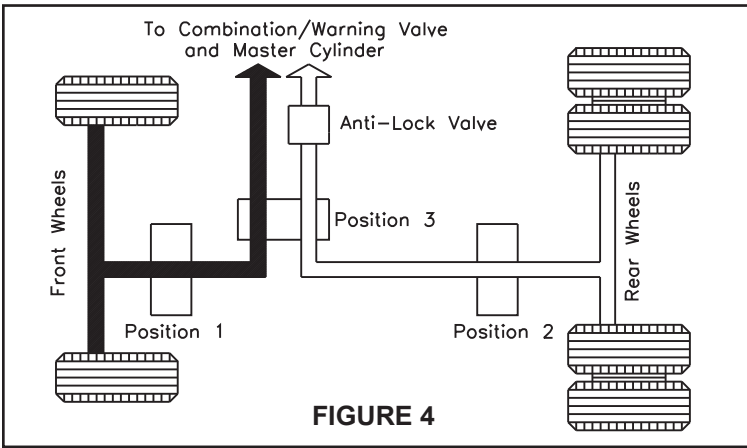

### TYPICAL REAR WHEEL ANTI-LOCK SYSTEM

Two independent braking systems. One system leads to the front brakes and the other system to the rear brakes.

**Identifying Feature:**

1. Two lines from master cylinder.
2. Anti-lock control valve between master cylinder and rear wheels

**Lock Position:**

(1) Front Axle      (2) Rear Axle      (3) 4-Wheel

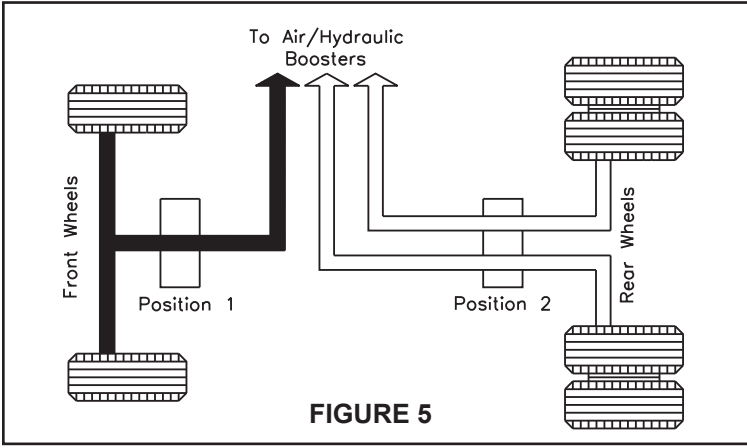

### IMPORTED TRUCK 3-CHANNEL ALL-WHEEL ANTI-LOCK SYSTEM

Provides braking control by way of independent anti-lock channels for each rear wheel and a third channel for the front wheels.

**Identifying Feature:**

1. Three separate air/hydraulic brake boosters.
2. One line to front brakes.
3. Separate lines to each rear wheel.

**Lock Position:**

(1) Front Axle      (2) Rear Axle      (1 and 2) 4-Wheel

**NOTE:** The anti-lock functions on air booster system, not the hydraulic side.

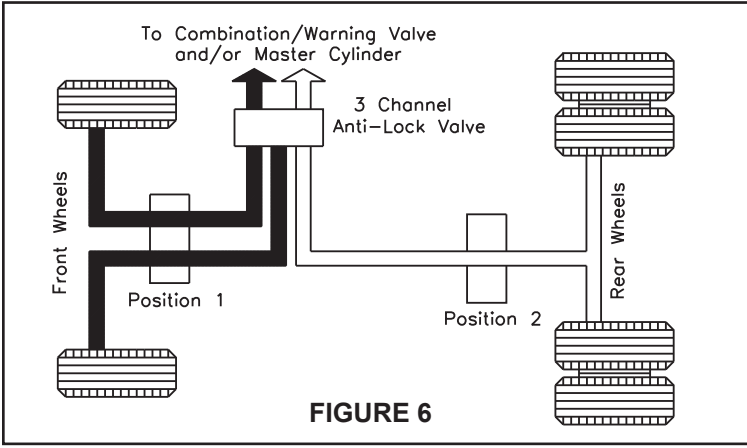

### TYPICAL 3-CHANNEL ALL-WHEEL ANTI-LOCK SYSTEM

Provides braking control by way of independent anti-lock channels for each front wheel and a third channel for both rear wheels.

**Identifying Feature:**

1. Two lines from master cylinder to anti-lock valve(s).
2. One line from anti-lock valve to rear brakes.
3. Separate lines from anti-lock valve to each front wheel.

**Lock Position:**

(1) Front Axle      (2) Rear Axle      (1 and 2) 4-Wheel

**NOTE:** Some 3-channel anti-lock brake systems use two separate anti-lock valve assemblies.

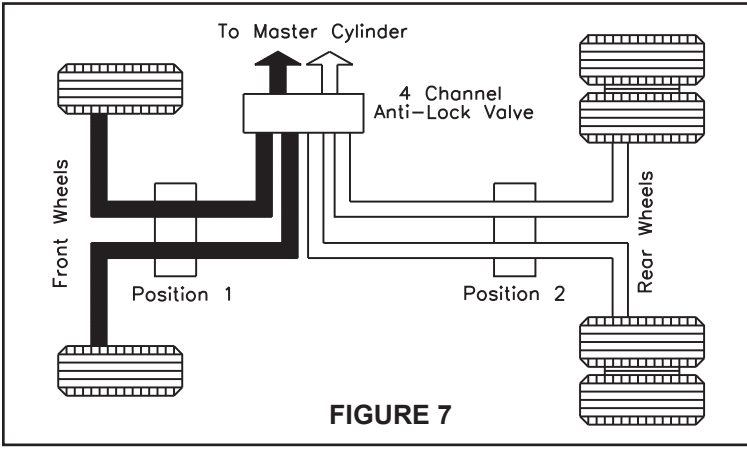

### TYPICAL 4-CHANNEL ALL-WHEEL ANTI-LOCK SYSTEM

Provides braking control by way of an independent channel for each front wheel and each rear wheel.

**Identifying Feature:**

1. Two lines from master cylinder to anti-lock valve.
2. Separate lines from anti-lock valve to each of the front and rear wheels.

**Lock Position:**

(1) Front Axle      (2) Rear Axle      (1 and 2) 4-Wheel

**NOTE:** Some 4-channel anti-lock brake systems use two separate anti-lock valve assemblies.

# NORTH AMERICA MANUFACTURED

## Chevrolet - GMC

Light Duty (C/K 10, C/K 1500)				Vehicle Application			
Model Year	Brake System Type	Service Brakes	Miscellaneous Notes	Aerial Lift Bucket		Other Applications	
				4 Wheel	2 Wheel	4 Wheel	2 Wheel
1967-1987	Dual (Figure 2)	F-disc/R-drum	Early models had 4 wheel drum brakes.	02-691-209	02-691-109	02-691-209 02-640-169	02-691-109 02-640-125
1988-1994	Rear ABS (Figure 4)	F-disc/R-drum		02-691-209	02-691-109	02-691-209 02-640-169	02-691-109 02-640-125
1995-2009	3-channel ABS (Figure 6)	F-disc/R-drum		02-691-305	02-691-109■	02-691-305	02-691-109■ 02-640-125■
2010-2024	4-channel ABS (Figure 7)	F-disc/R-drum		02-691-403	02-691-209	02-691-403	02-691-209 02-640-169
Light Duty (C/K 20-30, C/K 2500-4500)							
Model Year	Brake System Type	Service Brakes	Miscellaneous Notes	4 Wheel	2 Wheel	4 Wheel	2 Wheel
1967-1987	Dual (Figure 2)	F-disc/R-drum	Early models had 4 wheel drum brakes.	02-691-209	02-691-109	02-691-209 02-640-169	02-691-109 02-640-125
1988-1994	Rear ABS (Figure 4)	F-disc/R-drum		02-691-209	02-691-109	02-691-209 02-640-169	02-691-109 02-640-125
1995-2013	3-channel ABS (Figure 6)	F-disc/R-drum		02-691-305	02-691-109■	02-691-305	02-691-109■ 02-640-125■
3500HD (All models have Hydraulic Boost Master Cylinders)							
Model Year	Brake System Type	Service Brakes	Miscellaneous Notes	4 Wheel	2 Wheel	4 Wheel	2 Wheel
1990-1992	Dual (Figure 2)	4 wheel disc	Load sensing valve at rear axle.	02-691-209	02-691-109	02-691-209 02-640-169	02-691-109 02-640-125
1993-1994	Rear ABS (Figure 4)	4 wheel disc	Load sensing valve at rear axle.	02-691-209	02-691-109	02-691-209 02-640-169	02-691-109 02-640-125
1995-2002	3-channel ABS (Figure 6)	4 wheel disc		02-691-305	02-691-109■	02-691-305	02-691-109■ 02-640-125■
2500HD, 3500HD, 4500HD, 5500HD, 6500HD (Equipped with Hydraulic Brakes)							
Model Year	Brake System Type	Service Brakes	Miscellaneous Notes	4 Wheel	2 Wheel	4 Wheel	2 Wheel
2020-2024	4-channel ABS (Figure 7)	4 wheel disc		02-691-403	02-691-209	02-691-403	02-691-209 02-640-169
Medium Duty (C50-C65, Kodiak & TopKick, C4500-C7500 Conventional Cab, T5500-T7500 Tilt Cab - Also Isuzu H-Series Conventional Cab)							
Model Year	Brake System Type	Service Brakes	Miscellaneous Notes	4 Wheel	2 Wheel	4 Wheel	2 Wheel
1970 to mid 1980's	Single (Figure 1)	Drum	Vacuum/Hydraulic Boost	02-691-101	02-691-101	02-691-101 02-640-023	02-691-101 02-640-023
1970 to mid 1980's	Dual (Figure 2)	Drum	Vacuum/Hydraulic Boost	02-691-201	02-691-101	02-691-201 02-640-169	02-691-101 02-640-023
1970 to mid 1980's	1 1/2 x 1/2 split (Figure 3)	Drum	A dual brake lock is required for either rear or 4 wheel lockup.	02-691-201	02-691-201	02-691-201	02-691-201 02-640-023♦
mid 1980's to 1996	Dual (Figure 2)	4 wheel disc	Hydraulic Boosted Master Cylinder	02-691-201	02-691-101	02-691-201 02-640-169	02-691-101 02-640-023
1997-2024	4-channel ABS (Figure 7)	4 wheel disc	4-channel ABS standard. Optional to delete available prior to 1 Mar 1999. +	02-691-403	02-691-209	02-691-403	02-691-209 02-640-169

+ With 4-channel ABS deleted, brake system type is Dual (Figure 2)

**NOTE: Vacuum/Hydraulic Boost = Vacuum assisted booster for hydraulic cylinder  
Hydraulic Boost Master Cylinder = Master cylinder driven by hydraulic booster powered by steering pump**

**Best Choice** ♦ Front wheel lockup only ■ Rear wheel lock up only 3-channel ABS

# NORTH AMERICA MANUFACTURED

## Dodge - Ram

Light Duty (D100, Ram 1500)				Vehicle Application			
Model Year	Brake System Type	Service Brakes	Miscellaneous Notes	Aerial Lift Bucket		Other Applications	
				4 Wheel	2 Wheel	4 Wheel	2 Wheel
mid 1970's to 1988	Dual (Figure 2)	F-disc/R-drum		02-691-209	02-691-109	02-691-209	02-691-109
						02-640-169	02-640-125
1989-1993	Rear ABS (Figure 4)	F-disc/R-drum	Anti-lock valve location at rear axle makes it difficult to install lock downstream from anti-lock valve. Single locks should go on front axle.	02-691-209	02-691-109	02-691-209	02-691-109
						02-640-169	02-640-125
1994-1998	Rear ABS (Figure 4)	F-disc/R-drum	3-channel ABS optional (Figure 6).	02-691-209▲	02-691-109■	02-691-209▲	02-691-109■
							02-640-125■
1999-2006	3-channel ABS (Figure 6)	F-disc/R-drum in 2001-2005 model year. 4 wheel disc all models 2006-2011 model year.	Rear ABS (Figure 4) standard on ST, STL. 3-channel ABS (Figure 6) standard on STX, Laramie, optional on others.	02-691-305	02-691-109■	02-691-305	02-691-109■
							02-640-125■
2007-2024	4-channel ABS (Figure 7)	4 wheel disc	2007-2008 ST, STL rear ABS (Figure 4) standard. 4-channel ABS (Figure 7) optional.	02-691-403	02-691-209	02-691-403	02-691-209
							02-640-169
Light Duty (D250-D350, Ram 2500-3500)							
Model Year	Brake System Type	Service Brakes	Miscellaneous Notes	4 Wheel	2 Wheel	4 Wheel	2 Wheel
mid 1970's to 1988	Dual (Figure 2)	F-disc/R-drum		02-691-209	02-691-109	02-691-209	02-691-109
						02-640-169	02-640-125
1989-1993	Rear ABS (Figure 4)	F-disc/R-drum	Anti-lock valve location at rear axle makes it difficult to install lock downstream from anti-lock valve. Single locks should go on front axle.	02-691-209	02-691-109	02-691-209	02-691-109
						02-640-169	02-640-125
1994-1998	Rear ABS (Figure 4)	F-disc/R-drum	3-channel ABS optional (Figure 6).	02-691-209▲	02-691-109■	02-691-209▲	02-691-109■
							02-640-125■
1999-2012	3-channel ABS (Figure 6)	F-disc/R-drum in 2001-2005 model year. 4 wheel disc all models 2006-2012 model year.		02-691-305	02-691-109*	02-691-305	02-691-109■
							02-640-125■
2013-2024	4-channel ABS (Figure 7)	4 wheel disc		02-691-403	02-691-209	02-691-403	02-691-209
							02-640-169
Medium Duty (Ram 4500-5500)							
Model Year	Brake System Type	Service Brakes	Miscellaneous Notes	4 Wheel	2 Wheel	4 Wheel	2 Wheel
2008-2012	3-channel ABS (Figure 6)	4 wheel disc		02-691-305	02-691-109■	02-691-305	02-691-109■
							02-640-125■
2013-2024	4-channel ABS (Figure 7)	4 wheel disc		02-691-403	02-691-209	02-691-403	02-691-209
							02-640-169

**NOTE:** Vacuum/Hydraulic Boost = Vacuum assisted booster for hydraulic cylinder  
 Hydraulic Boost Master Cylinder = Master cylinder driven by hydraulic booster powered by steering pump

**Best Choice**      ▲ On 3-channel ABS systems use 02-691-305      ■ Rear wheel lock up only 3-channel ABS

# NORTH AMERICA MANUFACTURED

## Ford

Light Duty (E150-E250, F150-F250) Less than 8600 lb GVW				Vehicle Application			
Model Year	Brake System Type	Service Brakes	Miscellaneous Notes	Aerial Lift Bucket		Other Applications	
				4 Wheel	2 Wheel	4 Wheel	2 Wheel
1967-1986	Dual (Figure 2)	F-disc/R-drum	Early models had 4 wheel drum brakes.	02-691-209	02-691-109	02-691-209 02-640-169	02-691-109 02-640-125
1987-1996	Rear ABS (Figure 4)	F-disc/R-drum		02-691-209	02-691-109	02-691-209 02-640-169	02-691-109 02-640-125
1997-2003	Rear ABS (Figure 4)	F-disc/R-drum	3-channel ABS optional (Figure 6).	02-691-209▲	02-691-109*	02-691-209▲ 02-640-169▲	02-691-109* 02-640-125*
2004-2009	3-channel ABS (Figure 6)	4 wheel disc		02-691-305	02-691-109*	02-691-305	02-691-109* 02-640-125*
2010-2024	4-channel ABS (Figure 7)	4 wheel disc		02-691-403	02-691-209	02-691-403	02-691-209 02-640-169
Light Duty (E250-E35, F250-F350) 8600 lb and greater GVW							
Model Year	Brake System Type	Service Brakes	Miscellaneous Notes	4 Wheel	2 Wheel	4 Wheel	2 Wheel
1967-1986	Dual (Figure 2)	F-disc/R-drum	Early models had 4 wheel drum brakes.	02-691-209	02-691-109	02-691-209 02-640-169	02-691-109 02-640-125
1987-1998	Rear ABS (Figure 4)	F-disc/R-drum		02-691-209	02-691-109	02-691-209 02-640-169	02-691-109 02-640-125
Super Duty							
Model Year	Brake System Type	Service Brakes	Miscellaneous Notes	4 Wheel	2 Wheel	4 Wheel	2 Wheel
1988-1998	Dual (Figure 2)	4 wheel disc		02-691-209	02-691-109	02-691-209 02-640-169	02-691-109 02-640-125
Super Duty (E250-E350, F250-F350) Less than 10,000 lb GVW, single rear wheel							
Model Year	Brake System Type	Service Brakes	Miscellaneous Notes	4 Wheel	2 Wheel	4 Wheel	2 Wheel
1999-2000	Rear ABS (Figure 4)	4 wheel disc	3-channel ABS optional (Figure 6).	02-691-209▲	02-691-109■	02-691-209▲ 02-640-169▲	02-691-109■ 02-640-125■
2001-2010	3-channel ABS (Figure 6)	4 wheel disc		02-691-305	02-691-109*	02-691-305	02-691-109■ 02-640-125■
2011-2024	4-channel ABS (Figure 7) on single rear wheel models	4 wheel disc		02-691-403	02-691-209	02-691-403	02-691-209 02-640-169
Super Duty (E350-E450, F350-F550) 10,000 lb and greater GVW, dual rear wheel							
Model Year	Brake System Type	Service Brakes	Miscellaneous Notes	4 Wheel	2 Wheel	4 Wheel	2 Wheel
1999-2017	3-channel ABS (Figure 6)	4 wheel disc		02-691-305	02-691-109■	02-691-305	02-691-109■ 02-640-125■
2017-2024	4-channel ABS (Figure 7)	4 wheel disc		02-691-403	02-691-209	02-691-403	02-691-209 02-640-169
Medium Duty (F650-F750) 23,000 lb and greater GVW							
Model Year	Brake System Type	Service Brakes	Miscellaneous Notes	4 Wheel	2 Wheel	4 Wheel	2 Wheel
2001-2024	4-channel ABS (Figure 7)	4 wheel disc		02-691-403	02-691-209	02-691-403	02-691-209 02-640-169
Medium Duty (F500-F800)							
Model Year	Brake System Type	Service Brakes	Miscellaneous Notes	4 Wheel	2 Wheel	4 Wheel	2 Wheel
1984-1999	Dual (Figure 2)	Drum or Disc/Drum	OEM spring-apply rear park brakes standard. Use lock on front brakes only.	NA	02-691-101♦	NA	02-691-101♦ 02-640-023♦

**NOTE: Vacuum/Hydraulic Boost = Vacuum assisted booster for hydraulic cylinder**  
**Hydraulic Boost Master Cylinder = master cylinder driven by hydraulic booster powered by steering pump**

**Best Choice** ♦ Front wheel lock up only ▲ On 3-channel ABS systems use 02-691-305 NA Not Applicable  
 ■ Rear wheel lock up only 3-channel ABS, front wheel only lockup use 02-691-223



# NORTH AMERICA MANUFACTURED

## Ford

Medium Duty (LCF) Cab Forward				Vehicle Application			
Model Year	Brake System Type	Service Brakes	Miscellaneous Notes	Aerial Lift Bucket		Other Applications	
				4 Wheel	2 Wheel	4 Wheel	2 Wheel
2005-2010	3-channel ABS (Figure 4)	4 wheel disc		02-691-305	02-691-109■	02-691-305	02-691-109■ 02-640-023■

## Freightliner

Medium Duty (Business Class F50-F80, M2, MT35-MT55)							
Model Year	Brake System Type	Service Brakes	Miscellaneous Notes	4 Wheel	2 Wheel	4 Wheel	2 Wheel
1991-1996	Dual (Figure 2)	4 wheel disc	Hydraulic Boost Master Cylinder.	02-691-201	02-691-101	02-691-201	02-691-101 02-640-169
1997-2018	4-channel ABS (Figure 7)	4 wheel disc	4-channel ABS standard. Option to delete available prior to 1 MAR 99. +	02-691-403	02-691-209	02-691-403	02-691-209 02-640-169

## International - Navistar

Medium Duty (S1600-S1800 Loadstar)							
Model Year	Brake System Type	Service Brakes	Miscellaneous Notes	4 Wheel	2 Wheel	4 Wheel	2 Wheel
1970-1987	Single (Figure 1)	Drum	Vacuum/Hydraulic Boost	02-691-101	02-691-101	02-691-101	02-691-101 02-640-023
1970-1987	1 1/2 x 1/2 split (Figure 3)	Drum	A dual brake lock is required for either rear or 4 wheel lockup.	02-691-201	02-691-201	02-691-201	02-691-201 02-640-023♦
1970-1987	Dual (Figure 2)	Drum	Hydrovac(s)	02-691-201	02-691-101	02-691-201	02-691-101 02-640-169

Medium Duty (Series 4600-4900's)							
Model Year	Brake System Type	Service Brakes	Miscellaneous Notes	4 Wheel	2 Wheel	4 Wheel	2 Wheel
1988-1998	Dual (Figure 2)	4 wheel disc	Hydraulic Boosted Master Cylinder.	02-691-201	02-691-101	02-691-201	02-691-101 02-640-169
1999-2001	4-channel ABS (Figure 7)	4 wheel disc	4 channel ABS standard. Option to delete was available prior to 1 MAR 99. +	02-691-403	02-691-209	02-691-403	02-691-209 02-640-169

Medium Duty (Durastar 4100-4300)							
Model Year	Brake System Type	Service Brakes	Miscellaneous Notes	4 Wheel	2 Wheel	4 Wheel	2 Wheel
2002-2018	4-channel ABS (Figure 7)	4 wheel disc	2009 and newer models use Merritor HPB.	02-691-403	02-691-209	02-691-403	02-691-209 02-640-169

Medium Duty (TerraStar Conventional cab)							
Model Year	Brake System Type	Service Brakes	Miscellaneous Notes	4 Wheel	2 Wheel	4 Wheel	2 Wheel
2011-2013	3-channel ABS (Figure 6)	4 wheel disc		02-691-305	02-691-109■	02-691-305	02-691-109■ 02-640-125■

Medium Duty (Citystar CF500-CF600 Cab Forward)							
Model Year	Brake System Type	Service Brakes	Miscellaneous Notes	4 Wheel	2 Wheel	4 Wheel	2 Wheel
2005-2010	3-channel ABS (Figure 6)	4 wheel disc		02-691-305	02-691-109■	02-691-305	02-691-109■ 02-640-023■

Medium Duty (CV Series, MV Series)							
Model Year	Brake System Type	Service Brakes	Miscellaneous Notes	4 Wheel	2 Wheel	4 Wheel	2 Wheel
2020-2024	4-channel ABS (Figure 7)	4 wheel disc		02-691-403	02-691-209	02-691-403	02-691-209 02-640-169

+ With 4-channel ABS deleted, brake system type is Dual (Figure 2)

**NOTE: Vacuum/Hydraulic Boost = Vacuum assisted booster for hydraulic cylinder**

**Hydraulic Boost Master Cylinder = master cylinder driven by hydraulic booster powered by steering pump**

Best Choice ♦ Front wheel lock up only ▲ On 3-channel ABS systems use 02-691-305 NA Not Applicable

■ Rear wheel lock up only 3-channel ABS, front wheel only lockup use 02-691-223

# NORTH AMERICA MANUFACTURED

Kenworth							
Medium Duty (T170-T370)				Vehicle Application			
Model Year	Brake System Type	Service Brakes	Miscellaneous Notes	Aerial Lift Bucket		Other Applications	
				4 Wheel	2 Wheel	4 Wheel	2 Wheel
2001-2024	4-channel ABS (Figure 7)	4 wheel disc		02-691-403	02-691-209	02-691-403	02-691-209 02-640-169

Peterbilt							
Medium Duty (Model 325-337)							
Model Year	Brake System Type	Service Brakes	Miscellaneous Notes	Aerial Lift Bucket		Other Applications	
				4 Wheel	2 Wheel	4 Wheel	2 Wheel
2001-2024	4-channel ABS (Figure 7)	4 wheel disc		02-691-403	02-691-209	02-691-403	02-691-209 02-640-169

Sterling							
Medium Duty (Bullet CONV45-CONV55)							
Model Year	Brake System Type	Service Brakes	Miscellaneous Notes	Aerial Lift Bucket		Other Applications	
				4 Wheel	2 Wheel	4 Wheel	2 Wheel
2008-2009	3-channel ABS (Figure 6)	4 wheel disc		02-691-305	02-691-109■	02-691-305	02-691-109■ 02-640-125■

Medium Duty (Actera 5500-7500)							
Model Year	Brake System Type	Service Brakes	Miscellaneous Notes	Aerial Lift Bucket		Other Applications	
				4 Wheel	2 Wheel	4 Wheel	2 Wheel
2001-2009	4-channel ABS (Figure 7)	4 wheel disc		02-691-403	02-691-209	02-691-403	02-691-209 02-640-169

Toyota							
Tundra							
Model Year	Brake System Type	Service Brakes	Miscellaneous Notes	Aerial Lift Bucket		Other Applications	
				4 Wheel	2 Wheel	4 Wheel	2 Wheel
2008-2024	4-channel ABS (Figure 7)	4 wheel disc		02-691-403	02-691-209	02-691-403	02-691-209 02-640-169

NOTE: Vacuum/Hydraulic Boost = Vacuum assisted booster for hydraulic cylinder  
 Hydraulic Boost Master Cylinder = master cylinder driven by hydraulic booster powered by steering pump

Best Choice  Rear wheel lockup only     Rear wheel lock up only 3-channel ABS

# OFFSHORE MANUFACTURED

## Dodge - Freightliner Spinter

Light Duty (Van & Cab-chassis)				Vehicle Application			
Model Year	Brake System Type	Service Brakes	Miscellaneous Notes	4 Wheel	2 Wheel	4 Wheel	2 Wheel
2002-2024	4-channel ABS (Figure 7)	4 wheel disc		02-691-403	02-691-209	02-691-403	02-691-209 02-640-169

## General Motors "W" Series Chevrolet Tiltmaster - GMC Forward

Light Duty (W3500-W4500) also W5500 through 1998 model year							
Model Year	Brake System Type	Service Brakes	Miscellaneous Notes	4 Wheel	2 Wheel	4 Wheel	2 Wheel
1986-1998	Dual (Figure 2)	Disc/Drum-Drum	Vacuum/Hydraulic Booster	02-691-209	02-691-109	02-691-209	02-691-109 02-640-169 02-640-023
2000-2009	4-channel ABS (Figure 7)	F-disc/R-drum	Vacuum/Hydraulic Booster	02-691-403	02-691-209	02-691-403	02-691-209 02-640-169

Medium Duty (W5500-W5500HD)							
Model Year	Brake System Type	Service Brakes	Miscellaneous Notes	4 Wheel	2 Wheel	4 Wheel	2 Wheel
2000	3-channel ABS (Figure 5)	Disc/Drum-Drum	Air/Hydraulic Boost with ABS on the air side.	02-691-303	02-691-209 □	02-691-303	02-691-209 □ 02-640-169 □
2000-2009	4-channel ABS (Figure 7)	4 wheel disc	4-channel ABS Vac/Hyd Vacuum/Hydraulic Booster, 2005-2007 HD is Hyd/Hyd.	02-691-403	02-691-209	02-691-403	02-691-209 02-640-169

Medium Duty (WT5500)							
Model Year	Brake System Type	Service Brakes	Miscellaneous Notes	4 Wheel	2 Wheel	4 Wheel	2 Wheel
2000-2004	3-channel ABS (Figure 5)	Disc/Drum-Drum	Air/Hydraulic Boost with ABS on the air side.	02-691-303	02-691-209 □	02-691-303	02-691-209 □ 02-640-169 □

## Hino

Cab Over (FA)							
Model Year	Brake System Type	Service Brakes	Miscellaneous Notes	4 Wheel	2 Wheel	4 Wheel	2 Wheel
2001-2004	3-channel ABS (Figure 5)	4 wheel drum	Vacuum/Hydraulic, Air/Hydraulic Booster.	02-691-305	02-691-209 □	02-691-305	02-691-209 □ 02-640-169 □

Cab Over (FB, FD, FF)							
Model Year	Brake System Type	Service Brakes	Miscellaneous Notes	4 Wheel	2 Wheel	4 Wheel	2 Wheel
2001-2004	3-channel ABS (Figure 5)	4 wheel drum	Air/Hydraulic Boost with ABS on the air side.	02-691-303	02-691-209 □	02-691-303	02-691-209 □ 02-640-169 □

Cab Over (195-195H)							
Model Year	Brake System Type	Service Brakes	Miscellaneous Notes	4 Wheel	2 Wheel	4 Wheel	2 Wheel
2012-2024	4-channel ABS (Figure 7)	4 wheel drum	Hydraulic Booster	02-691-403	02-691-209	02-691-403	02-691-209

Conventional Cab (145-268)							
Model Year	Brake System Type	Service Brakes	Miscellaneous Notes	4 Wheel	2 Wheel	4 Wheel	2 Wheel
2005-2024	4-channel ABS (Figure 7)	4 wheel drum	Hydraulic Booster	02-691-403	02-691-209	02-691-403	02-691-209

Conventional Cab (238-268)							
Model Year	Brake System Type	Service Brakes	Miscellaneous Notes	4 Wheel	2 Wheel	4 Wheel	2 Wheel
2012-2024	4-channel ABS (Figure 7)	4 wheel drum	Hydraulic Booster	02-691-403	02-691-209	02-691-403	02-691-209

**NOTE:** Vacuum/Hydraulic Boost = Vacuum assisted booster for hydraulic cylinder  
Hydraulic Boost Master Cylinder = master cylinder driven by hydraulic booster powered by steering pump

Best Choice □ Rear wheel lockup only ■ Rear wheel lock up only 3-channel ABS

# OFFSHORE MANUFACTURED

## Isuzu

Light Duty (NPR, NPR-HD, NQR, NRR)				Vehicle Application			
Model Year	Brake System Type	Service Brakes	Miscellaneous Notes	Interlock Applications / Aerial Lift Bucket		Other Applications	
				4 Wheel	2 Wheel	4 Wheel	2 Wheel
1986-1998	Dual (Figure 2)	Disc/Drum-Drum	Vacuum/Hydraulic	02-691-209	02-691-109	02-691-209 02-640-169	02-691-109 02-640-023
2000-2024	4-channel ABS (Figure 7)	F-disc/R-drum	Vacuum/Hydraulic or Hydraulic/Hydraulic.	02-691-403	02-691-209	02-691-403	02-691-209 02-640-169
Medium Duty (FRR)							
Model Year	Brake System Type	Service Brakes	Miscellaneous Notes	4 Wheel	2 Wheel	4 Wheel	2 Wheel
1988-1998	Dual (Figure 2)	Drum	Air/Hydraulic	02-691-209	02-691-109	02-691-209 02-640-169	02-691-109 02-640-023
2000-2004	3-channel ABS (Figure 5)	4 wheel drum	Air/Hydraulic Boost with ABS on the air side.	02-691-303	02-691-209 □	02-691-303	02-691-209 □ 02-640-169 □
Medium Duty (FSR, FTR, FVR)							
Model Year	Brake System Type	Service Brakes	Miscellaneous Notes	4 Wheel	2 Wheel	4 Wheel	2 Wheel
1999-2010	4-channel ABS (Figure 7)	4 wheel disc	Hydraulic Booster	02-691-403	02-691-209	02-691-403	02-691-209 02-640-169

NOTE: For Isuzu H-Series conventional cabs - See Chevrolet Medium Duty section.

## Mitsubishi - Fuso

Light-Medium Duty (FE-FG, 125-180)							
Model Year	Brake System Type	Service Brakes	Miscellaneous Notes	4 Wheel	2 Wheel	4 Wheel	2 Wheel
1991-1998	Dual (Figure 2)	Drum		02-691-209	02-691-109	02-691-209 02-640-169	02-691-209 02-640-023
2000-2024	4-channel ABS (Figure 7)	F-disc/R-drum, 4 wheel disc, or 4 wheel drum	Vacuum/Hydraulic Booster	02-691-403	02-691-209	02-691-403	02-691-209 02-640-169
Medium Duty (FH)							
Model Year	Brake System Type	Service Brakes	Miscellaneous Notes	4 Wheel	2 Wheel	4 Wheel	2 Wheel
1996-1998	Dual (Figure 2)	4 wheel drum	Air/Hydraulic Boosters	02-691-201♣	02-691-101♣	02-691-201♣ 02-640-169	02-691-101♣ 02-640-023
2000-2004	4-channel ABS (Figure 7)	4 wheel drum	Hydraulic Booster	02-691-403	02-691-209	02-691-403	02-691-209 02-640-169
Medium Duty (FK, FM-MR, FM-HR, FM260)							
Model Year	Brake System Type	Service Brakes	Miscellaneous Notes	4 Wheel	2 Wheel	4 Wheel	2 Wheel
1991-1998	Dual (Figure 2)	4 wheel drum		02-691-201♣	02-691-101♣	02-691-201♣ 02-640-169	02-691-101♣ 02-640-023
1999-2010	3-channel ABS (Figure 5)	4 wheel drum	3-channel ABS Air/Hydraulic Boost with ABS on air side.	02-691-303	02-691-209 □	02-691-303	02-691-209 □ 02-640-169 □

NOTE: Vacuum/Hydraulic Boost = Vacuum assisted booster for hydraulic cylinder  
Hydraulic Boost Master Cylinder = master cylinder driven by hydraulic booster powered by steering pump

Best Choice □ Rear wheel lockup only ♣ 02-600-038 Remote Reservoir Kit recommended if power unit is mounted on frame rail (See page 14)

# OFFSHORE MANUFACTURED

## UD

Light Duty (1200-1400)				Vehicle Application			
Model Year	Brake System Type	Service Brakes	Miscellaneous Notes	Interlock Applications / Aerial Lift Bucket		Other Applications	
				4 Wheel	2 Wheel	4 Wheel	2 Wheel
1990-1998	Dual (Figure 2)	4 wheel drum	Vacuum/Hydraulic Booster	02-691-209	02-691-109	02-691-209	02-691-109
						02-640-169	02-640-023
2000-2012	4-channel ABS (Figure 7)	F-disc/R-drum, or 4 wheel disc	Vacuum/Hydraulic Booster	02-691-403	02-691-209	02-691403	02-691-209
							02-640-169
Medium Duty (1800-2600)							
Model Year	Brake System Type	Service Brakes	Miscellaneous Notes	4 Wheel	2 Wheel	4 Wheel	2 Wheel
1990-1998	Dual (Figure 2)	4 wheel drum	Air/Hydraulic Boosters. On trucks with optional air-rear parking brake, lock front brakes only.	02-691-201♣	02-691-101♣	02-691-201♣	02-691-101♣
						02-640-169	02-640-023
2000-2024	4-channel ABS (Figure 7)	4 wheel drum	Air/Hydraulic Boosters. On trucks with optional air-rear parking brake, lock front brakes only.	02-691-403	02-691-209	02-691-403	02-691-209
							02-640-169

**NOTE:** Vacuum/Hydraulic Boost = Vacuum assisted booster for hydraulic cylinder  
 Hydraulic Boost Master Cylinder = master cylinder driven by hydraulic booster powered by steering pump

**Best Choice** ♣ 02-600-038 Remote Reservoir Kit recommended if power unit is mounted on frame rail (See page 14)

### NOTE

1999 was a transition year to ABS systems on most imported trucks. If a 1999 model does not have ABS, use the 1998 recommendations. Use the 2000 recommendations for trucks having ABS.

# 691 ACCESSORIES

## Remote Reservoir

For use in brake fluid applications

ZF offers a remote reservoir kit (part number 02-600-038) for installations where the 691 Power Unit brass breather plug cannot be mounted in an upright position away from dust and dirt, or when visual monitoring of fluid level is desired.

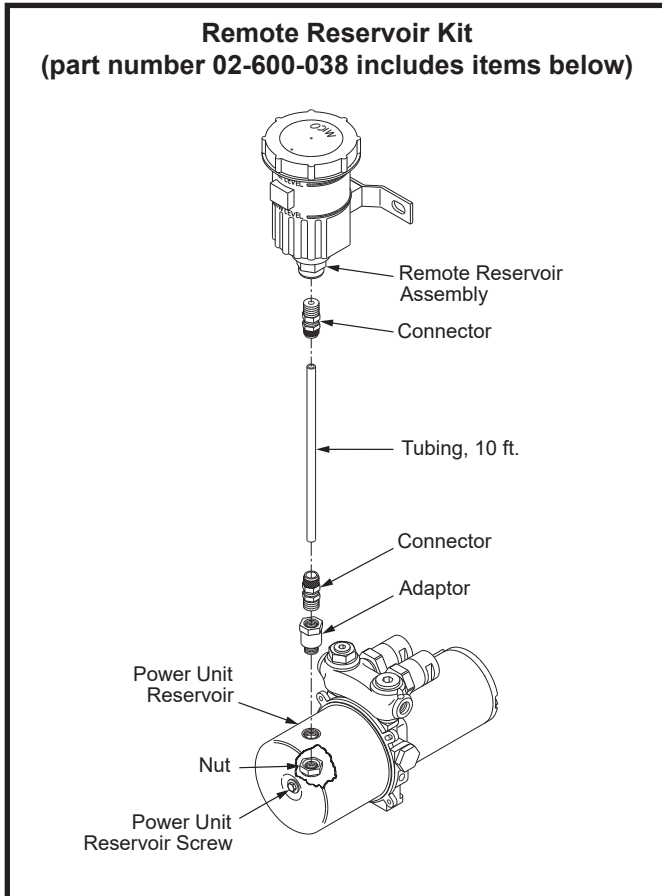

## Elbow Fittings and Straight Adapters

Simplify plumbing installation using 90° or 45° elbows and straight adapters available from ZF Off-Highway Solutions Minnesota Inc. These fittings allow more direct routing of brake tubes with fewer bends and are handy when mounting components in close quarters.

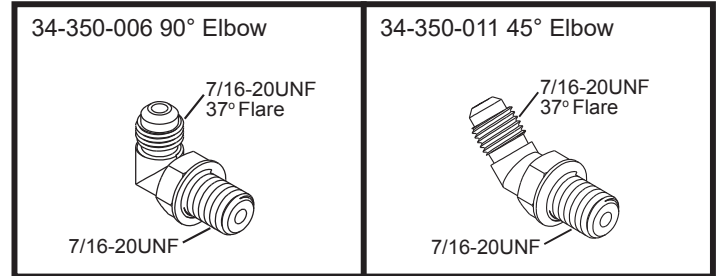

## Wire Harness Extension

The 11 ft. supplemental wire harness (part number 32-820-022) simplifies wiring when the 691 Control Module is mounted away from the 691 Power Unit. Uses waterproof adapters for quick connection of the control module and power unit leads.

## 691 MODELS AND SUB-COMPONENTS

System Model Number	Description	Power Unit	Control Module	Actuator	User Interface	Main Wire Harness
02-691-101	Single (1 3/4 in. bore)	20-410-014	29-585-001	20-460-013	32-585-007	32-820-021
02-691-109	Single (1 1/4 in. bore)	20-410-014	29-585-001	20-460-018	32-585-007	32-820-021
02-691-201	Dual (1 3/4 in bore)	20-410-014	29-585-001	20-460-012	32-585-007	32-820-021
02-691-209	Dual (1 1/4 in. bore)	20-410-014	29-585-001	20-460-017	32-585-007	32-820-021
** 02-691-223	Dual (1 1/4 in. bore)	20-410-014	29-585-001	20-460-018 (two)	32-585-007	32-820-021
*** 02-691-303	3-Channel	20-410-014	29-585-001	20-460-013 (one) 20-460-017 (one)	32-585-007	32-820-021
**** 02-691-305	3-Channel	20-410-014	29-585-001	20-460-018 (one) 20-460-017 (one)	32-585-007	32-820-021
***** 02-691-403	4-Channel	20-410-014	29-585-001	20-460-017 (two)	32-585-007	32-820-021

\*\* Consists of two 1 1/4 inch diameter single actuators.

\*\*\* Consists of one 1 3/4 inch diameter single actuator and one 1 1/4 inch diameter dual actuator.

\*\*\*\* Consists of one 1 1/4 inch diameter single actuator and one 1 1/4 inch diameter dual actuator.

\*\*\*\*\* Consists of two 1 1/4 inch diameter dual actuators.

## **WARNING**

1. All ZF Brake Locks are **supplemental** safety equipment which provide additional brake holding action **when used with existing vehicle parking brake**.
2. The Low Pressure Warning Switch must be used in combination with an audible and/or visual alarm to signal any loss of system pressure. The Low Pressure Warning Switch is explained in the Operating Instructions. **Do not disconnect Low Pressure Warning Switch** (does not apply for 691 Brake Lock System).
3. The 691 System must be used in combination with an audible and/or visual alarm to signal any loss of brake system pressure. **Do not disconnect vehicle horn/visual alarm or 691 Control Module alarm**.
4. All lines, fittings, and adjacent areas must be cleaned of dirt or road residue before any lines or fittings are disconnected. Special care should be taken so dirt and road residue are not allowed to enter hydraulic brake system. This could contaminate the system and interfere with proper operation of brakes and ZF brake locking devices.
5. Follow procedures outlined in Vehicle Manufacturer's Service Manual or SAE Standards when making new connections or adding to existing brake systems. Use only steel brake tubing conforming to SAE specifications.
6. Use only proper system fluid conforming to latest SAE or DOT Standards. Improper or contaminated fluid may cause gummy deposits and softening and swelling of other rubber seals in the entire brake system. Such a condition must be corrected immediately.
7. Do not use sealants, tapes, teflon or cement compounds on any connections or fittings. The sealants or compounds can contaminate the hydraulic brake system and interfere with the operation of the brake components or ZFlocking device.
8. All fittings and connections must be in good condition and tightened to proper torque values as specified in the Installation and Service Instructions.
9. Separate models numbers of ZF Brake Locks are available for brake fluid and for mineral based hydraulic oil. Select a model number that conforms with the type of fluid in the system.
10. Brake hoses, brake lines, ZF locking device, brake components, cylinders and all fittings must be routinely inspected for leaks, damage or wear. Adequate fluid levels must be maintained. In the event of any loss of fluid, brake system must be carefully inspected for leaks and corrected .
11. After installation, bleed system according to vehicle manufacturer recommendations.
12. Follow INSPECTIONS and TESTS section as outlined in the Operating Instructions.
13. The self-adhesive warning(s) accompanying each ZF locking device must be affixed in cab in view of operator.
14. The Operating Instructions must be placed in cab of vehicle in a location available to the operator.

This publication is not subject to any update service. Information contained in this publication was in effect at the time the publication was approved for printing and is subject to change without notice or liability. ZF Off-Highway Solutions Minnesota Inc. reserves the right to revise the information presented or to discontinue the production of parts described at any time.



**ZF Off-Highway Solutions Minnesota Inc.**

1911 Lee Boulevard / North Mankato, MN U.S.A. 56003

**Tel:** +1 507 625 6426 **Fax:** +1 507 625 3212