

Single Cable Lock



Installation and Service Instructions

NOTE

The hex flats on the lock sections may not be exactly aligned with one another, and the bleeder screw ports may not be positioned perfectly upright. DO NOT attempt to adjust or tamper with the hex flats of these sections or damage to the brake lock may occur.

**BRAKE FLUID
MODEL NUMBERS**
02-640-023

**MINERAL BASED HYDRAULIC OIL
MODEL NUMBERS**
02-640-122

READ GENERAL INSTALLATION GUIDELINES SHEET (81-600-001) BEFORE PROCEEDING

⚠ WARNING

1. All ZF Off-Highway Solutions Minnesota Inc. locking devices are **supplemental** safety equipment which provide additional brake holding action **when used with existing vehicle parking brake**.
2. The Low Pressure Warning Switch must be used in combination with an audible or visual alarm to signal any loss of system pressure. The Low Pressure Warning Switch is explained in the Operating Instructions (Form No. 81-640-039). **Do not disconnect Low Pressure Warning Switch.**
3. All lines, fittings and adjacent areas must be cleaned of dirt or road residue before any lines or fittings are disconnected. Special care must be taken so dirt and road residue are not allowed to enter hydraulic brake system. This can contaminate the system and interfere with proper operation of brakes and locking devices.
4. Follow procedures outlined in Vehicle Manufacturer Service Manual or SAE Standards when making new connections or adding to existing brake systems. Use only steel brake tubing conforming to SAE specifications.
5. Use only brake fluid conforming to latest SAE or DOT Standards. Improper or contaminated brake fluid may cause gummy deposits and softening and swelling of other rubber seals in the entire brake system. Such a condition must be corrected immediately.
6. Do not use sealants, tapes, teflon, or cement compounds on any connections or fittings. These sealants or compounds can contaminate the hydraulic brake system and interfere with the operation of brake components or locking device.
7. All fittings and connections must be in good condition and tightened to proper torque values as specified in the Installation and Service Instructions.
8. Separate models of ZF Off-Highway Solutions Minnesota Inc. locking devices are available for brake fluid and for mineral based hydraulic oil. Select a model that conforms with the type of fluid in the system.
9. Brake hoses, brake lines, locking device, brake components, cylinders, and all fittings must be routinely inspected for leaks, damage or wear. Adequate fluid levels must be maintained. In the event of any loss of fluid, the brake system must be carefully inspected for leaks.
10. After installation, bleed system according to vehicle manufacturer recommendations.
11. Follow INSPECTIONS and TESTS section as outlined in the Operating Instructions.
12. The self-adhesive warning label accompanying each locking device must be affixed in cab in view of the operator.
13. The Operating Instructions must be placed in cab of vehicle in a place available to the operator.

MOUNTING SINGLE CABLE LOCK

The Single Cable Lock is remotely mounted and uses a cable and knob to lock and release brakes.

Locate Single Cable Lock for operator's convenience and allow for complete movement of knob/cable.

Tubing is not supplied because of the variation in each installation. Install tubing using the shortest and most protected route. Use same size tubing when replacing a line, unless otherwise specified.

Thoroughly inspect port threads for any foreign material after removing vinyl plugs.

Bleeder screws provided must be used on installation. After installation the Single Cable Lock may contain air. This air, if not removed, will cause an ineffective and perhaps inoperative brake system.

1. Locate Single Cable Lock on vehicle frame. Allow for complete movement of linkage. Be sure that the Single Cable Lock does not interfere with other vehicle components.
2. Use the Single Cable Lock mounting bracket as a template, drill the necessary mounting holes.
3. Install the lock assembly using bolts, lock washers, and nuts.
4. Drill a 13 mm (0.50 in) diameter hole in the dash panel or use the universal mounting bracket instead.
5. Remove knob and lock nut from cable assembly.
6. Remove first 1/2 inch nut from cable assembly, leaving lock washer and second 1/2 inch nut on assembly.
7. Insert threaded end of cable through 13 mm (0.50 in) hole from back side of dash panel or through the universal mounting bracket.
8. Replace and tighten 1/2 inch nut 16.3-23.1 N·m (12-17 lb·ft) securing cable to dash panel or mounting bracket.
9. Replace lock nut and knob allowing 6.4 mm (0.25 in) clearance between lock nut and first 1/2 inch nut. See Figure 1.
10. Insert cable through firewall and route to cable clamp attached to Single Cable Lock assembly. Avoid sharp bends and kinks.
11. With cable held in position, move the knob and check for binding. Reposition cable if it is binding.
12. Pull knob out to retract inner cable core approximately 152.4 mm (6.00 in). Trim entire cable to fit installation.
13. Insert end of sheath into cable clamp in Single Cable Lock assembly and tighten set screw.
14. Install rubber boot on outside of cable housing, slide it on at least 6.4 mm (0.25 in).
15. Push knob in and feed inner cable core through core clamp on operating arm of Single Cable Lock assembly.

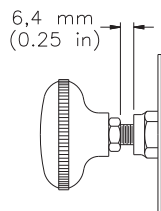

FIGURE 1

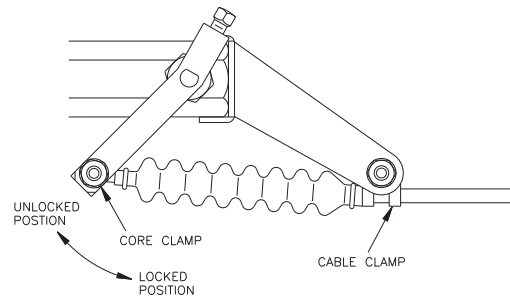

FIGURE 2

TORQUE SPECIFICATIONS

All hydraulic line connections must be torqued to specifications listed below and be free of leakage.

Thread Size	Torque
3/8-24	10.8-20.3 N·m (8-15 lb·ft)
7/16-24	16.3-23.0 N·m (12-17 lb·ft)
1/2-20	16.3-23.0 N·m (12-17 lb·ft)
9/16-18	20.3-33.9 N·m (15-25 lb·ft)

CONNECTING BRAKE LINES

(Refer to Figures 3, 4, 5, and 6)

NOTE

The Single Cable Lock can only be used to lock one wheel in a 4-Channel Anti-Lock System and should not be used.

WARNING

For all brake systems in use today, including anti-lock, the locking device must be installed between last hydraulic component in supply line and wheels.

Single System

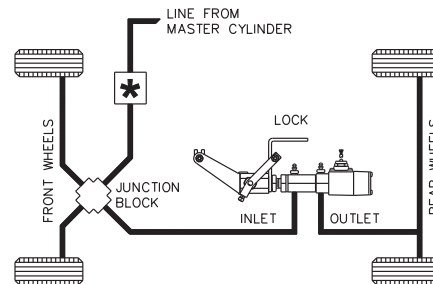

* If four-wheel lockup is desired, install lock in the line between master cylinder and junction block.

FIREWALL MOUNTED BOOSTER

FIGURE 3

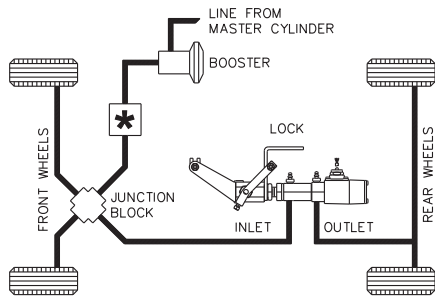

* If four-wheel lockup is desired, install lock in the line between master cylinder and junction block.

REMOTE MOUNTED BOOSTER
FIGURE 4

1. Disconnect line from rear wheels at junction block.
2. Install new line from the opened port of junction block to the INLET port of Single Cable Lock. Install bleeder screws in upper ports of Single Cable Lock.
3. Install new line in OUTLET port of Single Cable Lock and connect to line from rear wheels using tube union provided.

Dual System

If vehicle has front disc/rear drum brakes, it may not be possible to lock adequate pressure in the rear wheels. For these vehicles we recommend installing Single Cable Lock in front portion of system or preferably installing a Dual Cable Lock or 691 Dual Brake Lock System. Combination Warning Valve may not be used in some dual systems.

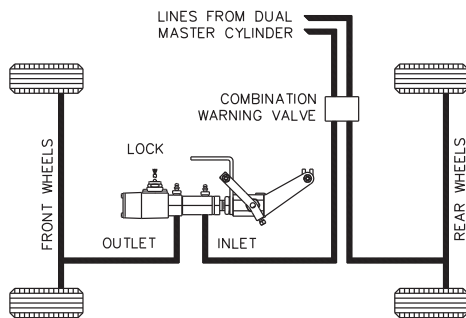

FIREWALL MOUNTED BOOSTER
FIGURE 5

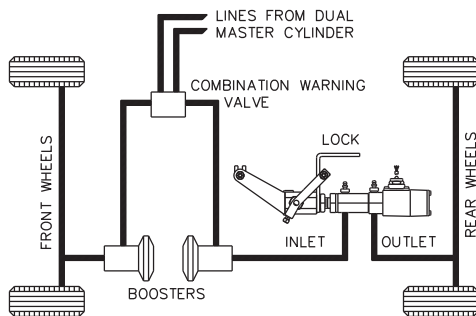

REMOTE MOUNTED BOOSTER
FIGURE 6

1. Disconnect line from wheels at the combination warning valve (anti-lock control valve on ABS systems). **NOTE: If there is a tube union in the line to wheels you may prefer to disconnect there.**
2. Install new line from the opened port to the INLET port of Lever Lock. Install bleeder screws in upper ports of Lever Lock.
3. Install new line in OUTLET port of Lever Lock and connect to line from wheels using a tube union.

CONNECTING HORN RELAY AND LOW PRESSURE WARNING SWITCH

(Refer to Figure 7)

⚠ CAUTION

If the vehicle does not have an auxiliary horn relay, or it is inaccessible, one will need to be installed. The auxiliary horn relay must be used when the electrical load exceeds 3 amps. Do not make connections from warning circuit directly to battery terminal, the pressure switch contacts will be damaged.

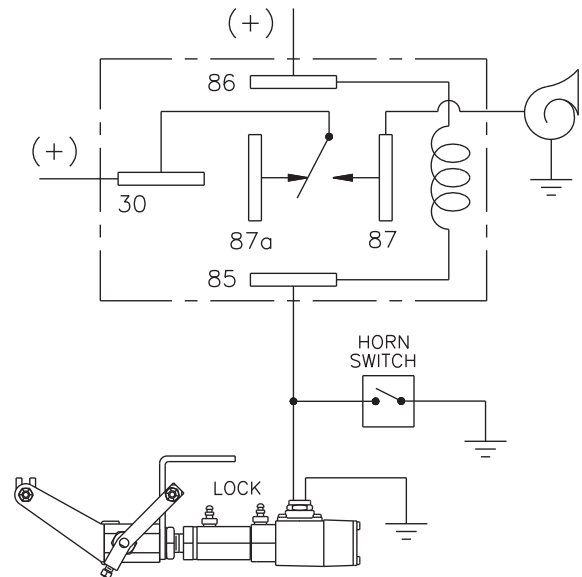

Typical Horn Relay
FIGURE 7

BLEEDING

See General Guidelines Sheet (Form No. 81-600-001) for bleeding instructions.

The hydraulic brake system must be bled whenever any line has been disconnected. There are two methods of bleeding hydraulic systems, pressure bleeding and manual bleeding. Both methods are acceptable and adequate but pressure bleeding is recommended if the equipment is available. Follow bleeding procedure and instructions as specified by vehicle manufacturer.

⚠ CAUTION

Use only Brake Fluid SAE J1703 or DOT 3 or 4 Brake Fluid or brake fluid specified by vehicle manufacturer. Never reuse brake fluid that has been drained from the system.

⚠ CAUTION

Before moving vehicle, a firm pedal must be achieved when lever lock is in full release position. If a firm pedal is not achieved, repeat bleeding procedure for lever lock and brake system until a firm pedal is achieved. Make several brake applications with vehicle stationary and check fittings for leaks.

TROUBLE SHOOTING GUIDE

Single Cable Lock is not field serviceable, do not attempt disassembly. If Single Cable Lock is damaged by contaminants or impaired in any way return to ZF Off-Highway Solutions Minnesota Inc. for reconditioning or replacement and service other components accordingly.

PROBLEM	POSSIBLE CAUSE	RECOMMENDED SERVICE
System locked up and brakes will not release	Master cylinder or booster malfunction	Bleed at booster. If brakes release, problem is booster. Replace booster.
	Lock installed incorrectly between master cylinder and booster	Replumb lock so it is installed between vehicle brake and last hydraulic component in supply line.
Brake system will not hold pressure	Leaking conditions in tubing and/or fittings	Check all tubing and fittings in brake system. Tighten or replace where required.
	Leak in wheel cylinder or caliper	Check for moist condition. If moist conditions exists replace or rebuild.
	Leak in lock valve	Replace Lock.
Low Pressure Warning Switch operates inadvertently or will not shut off	Locked up pressure leaking off	See problems and conditions under heading "Brake system will not hold pressure."
	Wiring improperly installed or short in wires	Check installation to conform with installation diagram. Check for shorted wiring.
Spongy or soft brake pedal	Air in system, improper bleeding at time of installation	Follow good bleeding practices. Use pressure bleeder when available.
	Slow leak in system	Check fittings and wheel cylinder for leaks. Tighten or replace fittings. Replace worn or damaged wheel cylinder.

This publication is not subject to any update service. Information contained in this publication was in effect at the time the publication was approved for printing and is subject to change without notice or liability. ZF Off-Highway Solutions Minnesota Inc. reserves the right to revise the information presented or to discontinue the production of parts described at any time.

